



POWER SUPPLY

- AC 100-240V wide-range input
- Width only 48mm
- Display for condition monitoring and easy analysis of power errors
- Efficiency up to 95.6%
- 20% output power reserves (PowerBoost)
- Easy fuse breaking – 3 times nominal current for 12ms
- Safe Hiccup^{PLUS} overload mode
- Full power between -25°C and +60°C
- DC OK relay contact
- ALARM relay contact
- Remote ON/OFF functionality
- Current sharing feature for parallel use
- 3 year warranty

PRODUCT DESCRIPTION

The CP20.248 is a DIN rail mountable single-phase-input power supply, which provides a floating, stabilized and galvanically separated SELV/PELV output voltage.

The device has a condition display integrated which shows real-time and recorded data informing about the condition of the power supply and the power line.

A DC OK signal, an alarm signal and remote ON/OFF make the unit suitable for many applications, where preventive function monitoring and remote control can help to avoid costly downtimes.

The devices also offer PowerBoost: Power reserves of 20%, which may even be used continuously at temperatures up to +45°C. Additionally it can deliver 3 times the nominal output current for 12ms, which helps to trip fuses on faulty output branches.

The device is equipped with a “Single Use / Parallel Use” feature, which enables a load sharing between power supplies when they are connected in parallel.

The Dimension CP-Series are cost optimized power supplies without compromising quality, reliability and performance. The most outstanding features of this series are the high efficiency, electronic inrush current limitation, active PFC, wide operational temperature range and the extraordinary small size.

SHORT-FORM DATA

Output voltage	DC 24V	Nominal
Adjustment range	24 - 28V	Factory setting 24.1V
AC 120 – 240V mains, DC 150-300V mains		
Output current	20.0 – 17.1A	Up to +60°C ambient
PowerBoost	24.0 – 20.6A	Up to +45°C ambient
Derating	linear 12.5W/K	> +60°C ambient
AC 100V mains, DC 110-150V mains		
Output current	17.5 – 15.0A	Up to +60°C ambient
PowerBoost	21.0 – 18.0A	Up to +45°C ambient
Derating	linear 10.5W/K	> +60°C ambient
Input voltage AC	AC 100-240V	-15%/+10%
Mains frequency	50-60Hz	±6%
Input current AC	4.26 / 2.23A	At 120 / 230Vac
Power factor	0.99 / 0.98	At 120 / 230Vac
Input voltage DC	DC 110-300V	±20%
Input current DC	4.64 / 1.66A	At 110 / 300Vdc
AC Inrush current	10.0 / 4.5A _{peak}	At 120 / 230Vac
Efficiency	94.2 / 95.6%	At 120 / 230Vac
Losses	29.6 / 22.1W	At 120 / 230Vac
Hold-up time	32 / 32ms	At 120 / 230Vac
Temperature range	-25°C to +70°C	
Size (WxHxD)	48x124x127mm	Without DIN rail
Weight	835g	

ORDER NUMBERS

Power Supply	CP20.248	
Accessory	ZM10.WALL	Wall/Panel mount bracket

MAIN APPROVALS

For details and the complete approval list, see chapter 22.



UL 61010-2-201

INDEX

	Page		Page
1. Intended Use	3	22. Approved, Fulfilled or Tested Standards.....	24
2. Installation Instructions.....	3	23. Regulatory Product Compliance	24
3. AC-Input	5	24. Physical Dimensions and Weight	25
4. DC-Input	6	25. Accessories.....	26
5. Input Inrush Current.....	6	25.1. ZM10.WALL – Wall/Panel Mount Bracket.....	26
6. Output	7	25.2. UF20.241 Buffer Module.....	27
7. Hold-up Time.....	9	25.3. YR40.241 - Redundancy Module	27
8. DC OK Relay Contact	9	25.4. YR40.242 - Redundancy Module	27
9. Power Supply Condition Display.....	10	25.5. YR40.245 - Redundancy Modules.....	28
10. Remote ON / OFF Function	13	26. Application Notes.....	29
11. "Alarm" Relay Contact.....	13	26.1. Peak Current Capability.....	29
12. Efficiency and Power Losses.....	14	26.2. Output Circuit Breakers.....	30
13. Functional Diagram	15	26.3. Charging of Batteries.....	31
14. Front Side and User Elements	16	26.4. Series Operation.....	31
15. Terminals and Wiring	17	26.5. Parallel Use to Increase Output Power	31
16. Lifetime Expectancy	18	26.6. Parallel Use for Redundancy	32
17. MTBF	18	26.7. Operation on Two Phases	33
18. EMC	19	26.8. Use in a Tightly Sealed Enclosure	33
19. Environment.....	21	26.9. Mounting Orientation	34
20. Safety and Protection Features	22		
21. Dielectric Strength.....	23		

The information given in this document is correct to the best of our knowledge and experience at the time of publication. If not expressly agreed otherwise, this information does not represent a warranty in the legal sense of the word. As the state of our knowledge and experience is constantly changing, the information in this data sheet is subject to revision. We therefore kindly ask you to always use the latest issue of this document (available under www.pulspower.com).

No part of this document may be reproduced or utilized in any form without our prior permission in writing.

Packaging and packaging aids can and should always be recycled. The product itself may not be disposed of as domestic refuse.

TERMINOLOGY AND ABBREVIATIONS

PE and \oplus symbol	PE is the abbreviation for Protective Earth and has the same meaning as the symbol \oplus .
Earth, Ground	This document uses the term "earth" which is the same as the U.S. term "ground".
t.b.d.	To be defined, value or description will follow later.
AC 230V	A figure displayed with the AC or DC before the value represents a nominal voltage with standard tolerances (usually $\pm 15\%$) included. E.g.: DC 12V describes a 12V battery disregarding whether it is full (13.7V) or flat (10V)
230Vac	A figure with the unit (Vac) at the end is a momentary figure without any additional tolerances included.
50Hz vs. 60Hz	As long as not otherwise stated, AC 230V parameters are valid at 50Hz mains frequency.
may	A key word indicating flexibility of choice with no implied preference.
shall	A key word indicating a mandatory requirement.
should	A key word indicating flexibility of choice with a strongly preferred implementation.
\Rightarrow	Action step
✓	Positive result
✗	Negative result

1. INTENDED USE

This device is designed for installation in an enclosure and is intended for commercial use, such as in industrial control, process control, monitoring and measurement equipment or the like.

Do not use this device in equipment, where malfunctioning may cause severe personal injury or threaten human life without additional appropriate safety devices, that are suited for the end-application.

If this device is used in a manner outside of its specification, the protection provided by the device may be impaired.

2. INSTALLATION INSTRUCTIONS

WARNING Risk of electrical shock, fire, personal injury or death

- Turn power off before working on the device. Protect against inadvertent re-powering.
- Do not modify or repair the unit.
- Do not open the unit as high voltages are present inside.
- Use caution to prevent any foreign objects from entering the housing.
- Do not use in wet locations or in areas where moisture or condensation can be expected.
- Do not touch during power-on, and immediately after power-off. Hot surfaces may cause burns.

Obey the following installation instructions:

This device may only be installed and put into operation by qualified personnel.

This device does not contain serviceable parts. The tripping of an internal fuse is caused by an internal defect.

If damage or malfunction should occur during installation or operation, immediately turn power off and send unit to the factory for inspection.

Install the device in an enclosure providing protection against electrical, mechanical and fire hazards.

Install the device onto a DIN rail according to EN 60715 with the input terminals on the bottom of the device.

Make sure that the wiring is correct by following all local and national codes. Use appropriate copper cables that are designed for a minimum operating temperature of 60°C for ambient temperatures up to +45°C, 75°C for ambient temperatures up to +60°C and 90°C for ambient temperatures up to +70°C. Ensure that all strands of a stranded wire enter the terminal connection. Use ferrules for wires on the input terminals. Unused screw terminals should be securely tightened.

The device is designed for pollution degree 2 areas in controlled environments. No condensation or frost is allowed.

The enclosure of the device provides a degree of protection of IP20. The housing does not provide protection against spilled liquids.

The device is designed as "Class of Protection I" equipment according to IEC 61140. Do not use without a proper PE (Protective Earth) connection.

The device is suitable to be supplied from TN, TT or IT mains networks. The continuous voltage between the input terminals and the PE potential must not exceed 300Vac.

The input can also be powered from a battery or a similar DC source. The continuous voltage between the supply voltage and the PE/ground potential must not exceed 375Vdc.

A disconnecting means shall be provided for the input of the device.

The device is designed for convection cooling and does not require an external fan. Do not obstruct airflow and do not cover ventilation grid!

The device is designed for altitudes up to 5000m. Above 2000m a reduction in output current and overvoltage category is required.

Keep the following minimum installation clearances:

Output power related to nominal	Installation clearance (mm)		
	top	bottom	side
< 50 %	40	20	0
≥ 50 %	40	20	5
≥ 90 %	40	20	15

The device is designed, tested and approved for branch circuits up to 32A (IEC) and 30A (UL) without additional protection device. If an external fuse is utilized, do not use circuit breakers smaller than 10A B- or C-Characteristic to avoid a nuisance tripping of the circuit breaker.

The maximum surrounding air temperature is +70°C. The operational temperature is the same as the ambient or surrounding air temperature and is defined 2cm below the device.

The device is designed to operate in areas between 5% and 95% relative humidity.

3. AC-INPUT

The device is suitable to be supplied from TN, TT or IT mains networks.

AC input voltage Range A	nom.	AC 120-240V	-15%/+10%
AC input voltage Range B	nom.	AC 100-240V	-15%/+10%
AC input range		85-264Vac	Continuous operation
		264-300Vac	Occasionally for maximal 500ms
Allowed voltage L or N to earth	max.	300Vac	Continuous, according to IEC 60664-1
Input frequency	nom.	50–60Hz	±6%
Turn-on voltage	typ.	82Vac	Steady-state value, see Fig. 3-1
Shut-down voltage	typ.	72Vac	Steady-state value, see Fig. 3-1
External input protection	See recommendations in chapter "Installation Instructions".		

		AC 100V	AC 120V	AC 230V	
Input current	typ.	5.15A	4.26A	2.23A	At 24V, 20A, see Fig. 3-3
Power factor	typ.	0.99	0.99	0.98	At 24V, 20A, see Fig. 3-4
Crest factor	typ.	1.65	1.63	1.63	At 24V, 20A, The crest factor is the mathematical ratio of the peak value to RMS value of the input current waveform.
Start-up delay	typ.	700ms	630ms	500ms	See Fig. 3-2
Rise time	typ.	110ms	110ms	110ms	At 24V, 20A const. current load, 0mF load capacitance, see Fig. 3-2
	typ.	120ms	120ms	120ms	At 24V, 20A const. current load, 20mF load capacitance, see Fig. 3-2
Turn-on overshoot	max.	200mV	200mV	200mV	In single use mode, see Fig. 3-2

Fig. 3-1 Input voltage range

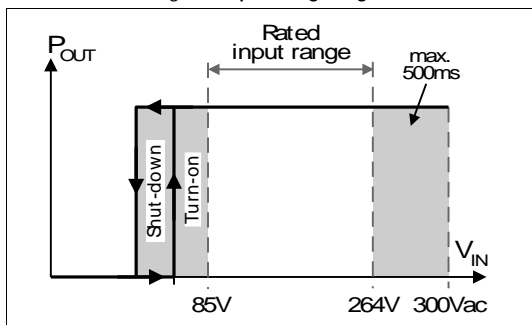

Fig. 3-2 Turn-on behavior, definitions

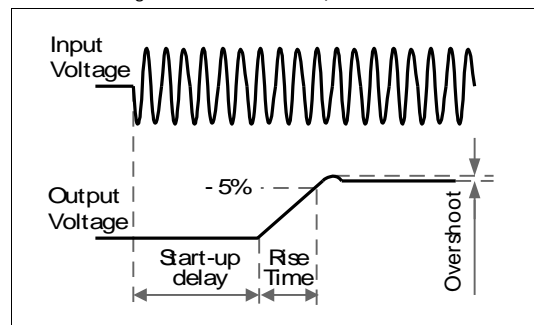

Fig. 3-3 Input current vs. output current at 24V output voltage

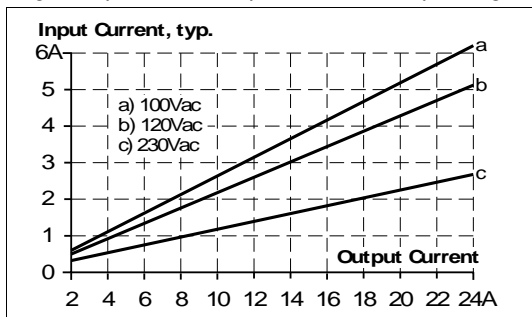
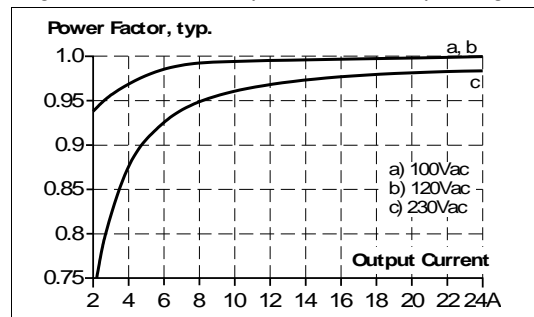

Fig. 3-4 Power factor vs. output current at 24V output voltage



4. DC-INPUT

The device is suitable to be supplied from a DC input voltage. Use a battery or a similar DC source.

A supply from the intermediate DC-bus of a frequency converter is not recommended and can cause a malfunction or damage the unit.

Connect +pole to L, -pole to N and the PE terminal to an earth wire or to the machine ground.

DC input voltage Range A	nom.	DC 150-300V	±20%
DC input voltage Range B	nom.	DC 110-150V	±20%
DC input range		88-360Vdc	
DC input current	typ.	4.64A 1.66A	At 110Vdc, at 24V, 20A At 300Vdc, at 24V, 20A
Allowed Voltage L/N to Earth	max.	375Vdc	Continuous, according to IEC 62477-1
Turn-on voltage	typ.	80Vdc	Steady state value
Shut-down voltage	typ.	70Vdc	Steady state value

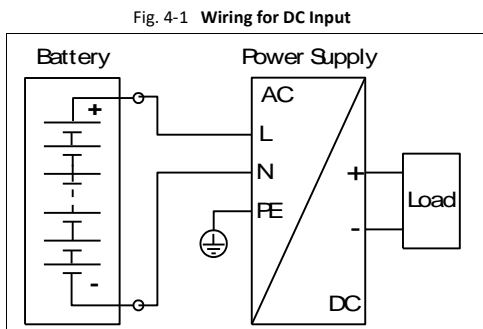

5. INPUT INRUSH CURRENT

An active inrush limitation circuit limits the input inrush current after turn-on of the input voltage.

The charging current into EMI suppression capacitors is disregarded in the first microseconds after switch-on.

		AC 100V	AC 120V	AC 230V	
Inrush current	max.	15A _{peak}	12A _{peak}	5.5A _{peak}	Temperature independent
	typ.	12A _{peak}	10A _{peak}	4.5A _{peak}	Temperature independent
Inrush energy	max.	1A ² s	1A ² s	1A ² s	Temperature independent

Fig. 5-1 Typical turn-on behavior at nominal load and 25°C ambient

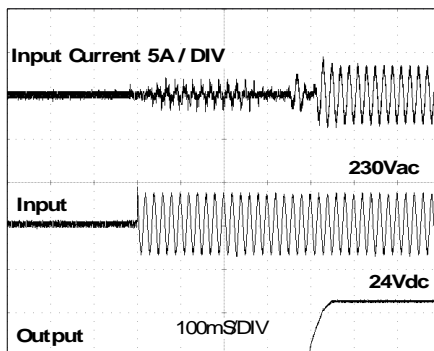

6. OUTPUT

The output provides a SELV/PELV rated voltage, which is galvanically isolated from the input voltage. The output is electronically protected against no-load, overload and short circuit. In case of a protection event, audible noise may occur.

The output is designed to supply any kind of loads, including inductive and capacitive loads. If capacitors with a capacitance >1F are connected, the unit might charge the capacitor in an intermittent mode.

At heavy overloads (when output voltage falls below 13V), the power supply delivers continuous output current for 2s. After this, the output is switched off for approx. 18s before a new start attempt is automatically performed. This cycle is repeated as long as the overload exists. If the overload has been cleared, the device will operate normally.

The device is equipped with a "Single Use / Parallel Use" feature, which can be selected on the front of the unit. The "Parallel Use" mode regulates the output voltage in such a manner that the voltage at no load is approx. 4% higher than at nominal load. This achieves a load sharing between power supplies when they are connected in parallel.

Output voltage	nom.	24V	
Adjustment range	min.	24-28V	Guaranteed value
	max.	30V	This is the maximum output voltage which can occur at the clockwise end position of the potentiometer due to tolerances. It is not a guaranteed value which can be achieved.
Factory setting output voltage	typ.	24.1V	±0.2% in "single use" mode at full load, cold unit
	typ.	24.1V	±0.2% in "parallel use" mode at 20A, cold unit (results to 23.9V ±0.2% at 24A and 25.1V ±0.2% at no load), see Fig. 6-2
Line regulation	max.	10mV	Between 85 and 300Vac input voltage change
Load regulation	max.	100mV	Between 0 and 24A in "single use" mode, static value
	typ.	1000mV	Between 0 and 20A in "parallel use" mode, static value
Ripple and noise voltage	max.	50mVpp	Bandwidth 20Hz to 20MHz, 500hm
Output current Range A	nom.	20.0A	At 24V and up to +60°C ambient temperature
	nom.	14.8A	At 24V and +70°C ambient temperature
	nom.	17.1A	At 28V and up to +60°C ambient temperature
	nom.	12.7A	At 28V and +70°C ambient temperature
			Derate linearly between +60°C to +70°C, see chapter 19
PowerBoost Range A ¹⁾	nom.	24.0A	At 24V and up to 45°C ambient temperature, see Fig. 19-1
	nom.	20.6A	At 28V and up to 45°C ambient temperature, see Fig. 19-1
			PowerBoost decreases linearly to nominal power between +45°C and +60°C, see chapter 19
Output current Range B	nom.	17.5A	At 24V and up to +60°C ambient temperature
	nom.	13.1A	At 24V and +70°C ambient temperature
	nom.	15.0A	At 28V and up to +60°C ambient temperature
	nom.	11.3A	At 28V and +70°C ambient temperature
			Derate linearly between +60°C to +70°C, see chapter 19
PowerBoost Range B ¹⁾	nom.	21.0A	At 24V and up to 45°C ambient temperature, see Fig. 19-2
	nom.	18.0A	At 28V and up to 45°C ambient temperature, see Fig. 19-1
			PowerBoost decreases linearly to nominal power between +45°C and +60°C, see chapter 19
Fuse breaking current	typ.	60A	Up to 12ms once every five seconds, see Fig. 6 4. The fuse breaking current is an enhanced transient current which helps to trip fuses on faulty output branches. The output voltage stays above 20V.
Overload behavior		Continuous current	For output voltage above 13Vdc, see Fig. 6-1
		Intermittent current	For output voltage below 13Vdc, see Fig. 6-1

Overload/ short-circuit current	max.	29.8A	Continuous current, see Fig. 6-1 Intermitted current peak value for typ. 2s Load impedance 10mOhm, see Fig. 6-3 Discharge current of output capacitors is not included.
	typ.	29A	
	max.	9.8A	Intermitted current average value (R.M.S.) Load impedance 10mOhm, see Fig. 6-3
Output capacitance	typ.	8 500μF	Included inside the power supply
Back-feeding loads	max.	35V	The unit is resistant and does not show malfunctioning when a load feeds back voltage to the power supply. It does not matter whether the power supply is on or off. The absorbing energy can be calculated according to the built-in large sized output capacitor.

¹⁾ **PowerBoost**

This power/current is continuously allowed up to an ambient temperature of +45°C.
Above +45°C, do not use this power/current longer than a duty cycle of 10% and/or not longer than 1 minute every 10 minutes.

Fig. 6-1 Output voltage vs. output current, typ.

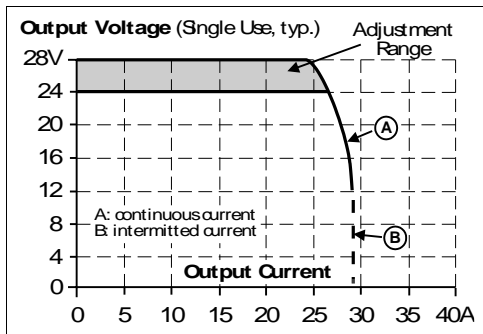

Fig. 6-2 Output voltage in "parallel use" mode, typ.

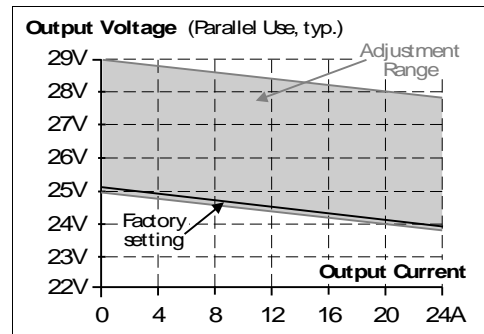

Fig. 6-3 Short-circuit on output, Hiccup^{PLUS} mode, typ.

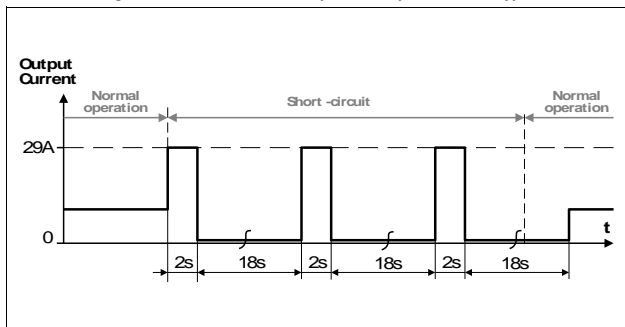
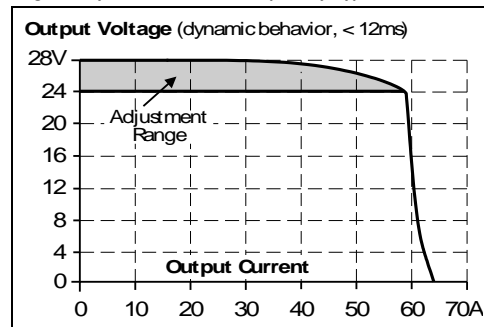

Fig. 6-4 Dynamic overcurrent capability, typ.



7. HOLD-UP TIME

The hold-up time is the time during which a power supply's output voltage remains within specification following the loss of input power. The hold-up time is output load dependent. At no load, the hold-up time can be up to several seconds. The green DC OK LED is also on during this time.

		AC 100V	AC 120V	AC 230V	
Hold-up Time	typ.	65ms	65ms	65ms	At 24V, 10A, see Fig. 7-1
	min.	54ms	54ms	54ms	At 24V, 10A, see Fig. 7-1
	typ.	32ms	32ms	32ms	At 24V, 20A, see Fig. 7-1
	min.	24ms	24ms	24ms	At 24V, 20A, see Fig. 7-1

Fig. 7-1 Hold-up time vs. input voltage

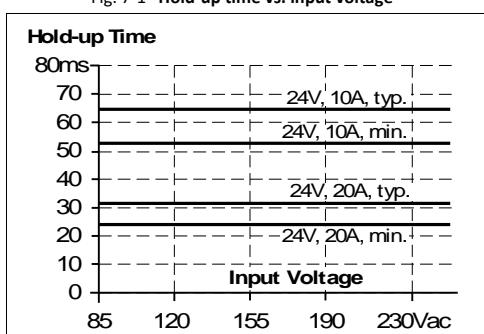
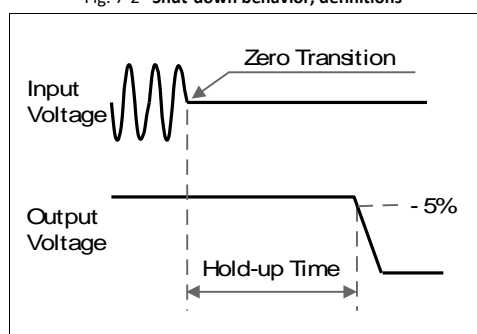

Fig. 7-2 Shut-down behavior, definitions



8. DC OK RELAY CONTACT

This feature monitors the output voltage on the output terminals of a running power supply.

The DC OK relay contact is not synchronized with the DC OK LED.

The voltage at the DC OK relay contacts must not exceed 60Vdc to earth. Max. 0.3A for resistive loads.

Contact closes	As soon as the output voltage reaches 22V.
Contact opens	As soon as the output voltage dips below 22V. Short dips will be extended to a signal length of 100ms. Dips shorter than 1ms will be ignored.
Switching hysteresis	Typically 0.7V
Contact ratings	Maximal 60Vdc 0.3A, 30Vdc 1A, 30Vac 0.5A, resistive load Minimal permissible load: 1mA at 5Vdc
Isolation voltage	See chapter "Dielectric Strength".

Fig. 8-1 DC OK relay contact behavior

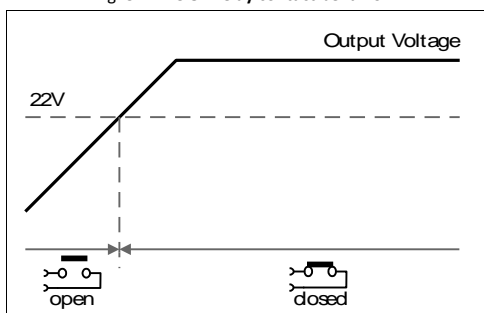

9. POWER SUPPLY CONDITION DISPLAY

Fig. 9-1 Power Supply Condition Display

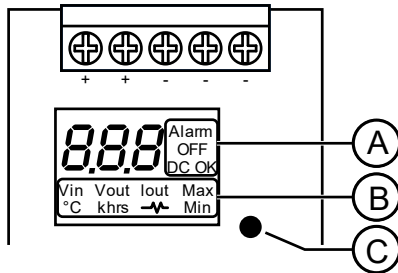

The device has an integrated Power Supply Condition Display (PSCD). It shows all the different power supply condition values on the front of the PSU for condition monitoring and easy analysis of power errors. When switched on, all LED segments of the PSCD light up for 2 seconds to indicate the full functionality of the display. At the next turn-on procedure, the PSCD shows the menu of the last turn-off sequence.

A) **Status Indicator:** (see Fig. 9-1) consists of three LEDs, showing the basic operation status of the PSU:

Alarm = an error has occurred (see **Troubleshooting**)
 OFF = input voltage is switched off via the shut-down-input
 DC OK = see chapter 8

B) **Denomination Fields:** display units of the condition values

C) **Display Push-Button:** only means to navigate through the PSCD

Functionalities of the PSCD

The PSCD has two operating modes:

The Real-Time Data Mode provides the concurrent condition values of the PSU on [Page 1](#).

The Recorded Data Mode continuously records min./max. condition values for analysis and monitoring purposes on [Page 2](#).

To start a new cycle of analysis the recorded data can be reset to the concurrent condition values (see **To reset recorded data**). For a more in-depth analysis, PEAK values of input voltage parameters can also be displayed and recorded (see **Display R.M.S./PEAK values**).

The detailed list of condition values can be found in the denomination fields (see Fig. 9-2):

Real-Time Data Mode: displayed on [Page 1](#)

- (1) Vin: Input voltage as R.M.S./PEAK value [V]
- (2) Vout: Output voltage [V]
- (3) Iout: Output current [A]
- (4) °C: Internal temperature [°C]
- (5) khrs: Total operating hours [khrs]

Recorded Data Mode: displayed on [Page 2](#)



- (1) Vin Min: Min. input voltage as R.M.S./PEAK value [V]
- (2) Vin Max: Max. input voltage as R.M.S./PEAK value [V]
- (3)  Min: Number of **undershoot** transient events on input voltage [Number of events]
- (4)  Max: Number of **overvoltage** transient events on input voltage [Number of events]
- (5) Vout Max: Max. output voltage [V]
- (6) Iout Max: Max. output current [A]
- (7) °C Min: Min. internal temperature [°C]
- (8) °C Max: Max. internal temperature [°C]

Fig. 9-2 Condition values displayed on the PSCD



Navigate through Real-Time Data Mode / Recorded Data Mode

- ⇒ Press the Display Push-Button less than 1 second to browse through the different condition values

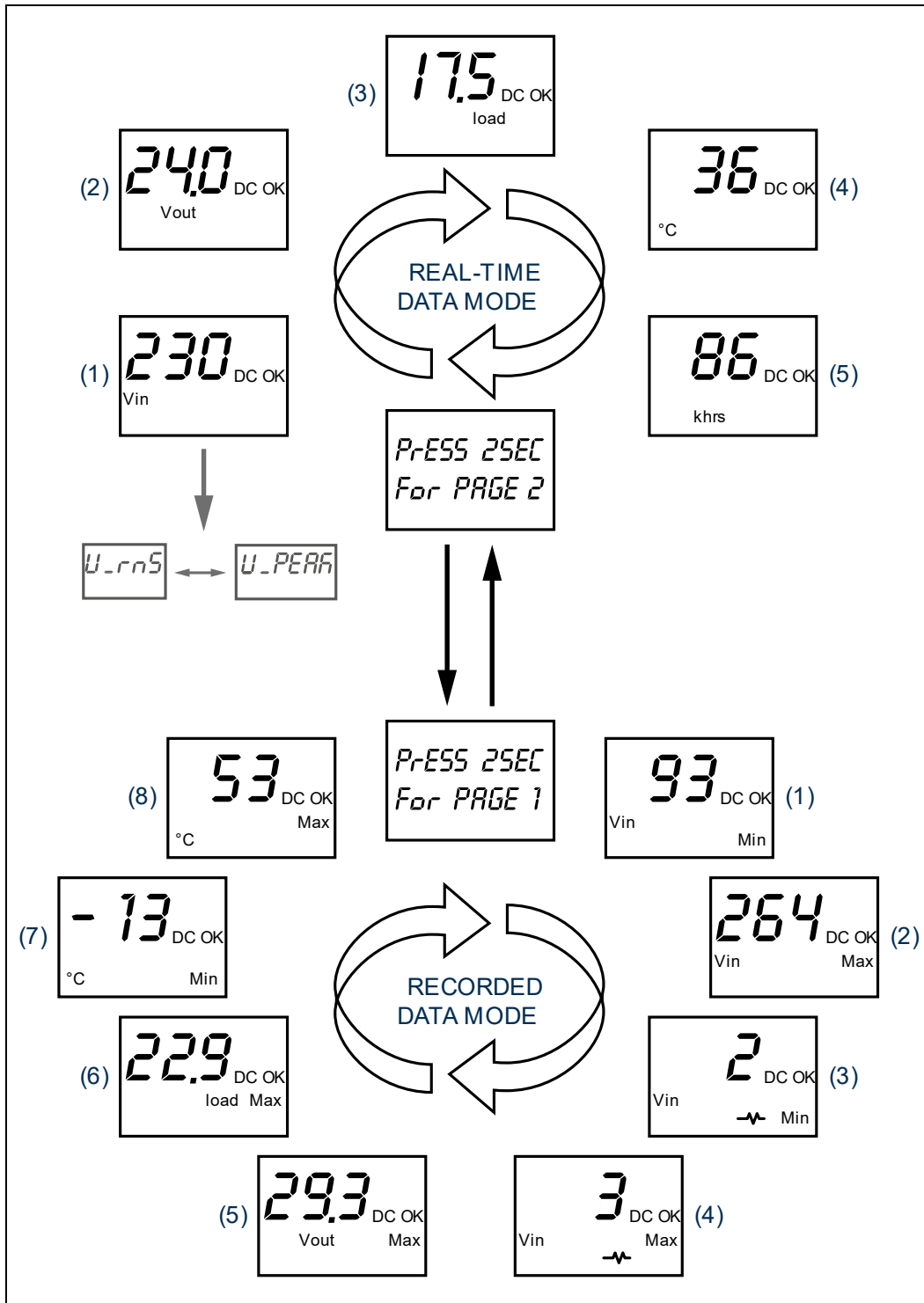
Access Real-Time Data Mode / Recorded Data Mode

To switch between Page 1 and Page 2:

- ⇒ Press the Display Push-Button and browse until display shows "Press 2 sec for page 1" or "Press 2 sec for page 2"
- ⇒ Press the Display Push-Button for 2 seconds
 - ✓ Display will switch to the other page
 - ✓ Page 1 shows Real-Time Data
 - ✓ Page 2 shows Recorded Data

To reset recorded data:

- ⇒ Access Page2: Recorded Data
 - ⇒ Press the Display Push-Button to select the data that needs to be reset
 - ⇒ Press the Display Push-Button for more than 2 seconds to activate reset
 - ✓ Reset initiated when the display flashes
 - ⇒ Continue to press the Display Push-Button until flashing stops
 - ✓ The value is reset to the current value
 - ✗ If the Display Push-Button is released before flashing ends, the value is not reset
- Note:** Min. and Max. values will be updated and recorded continuously until reset by the user

Fig. 9-3 Reset recorded data

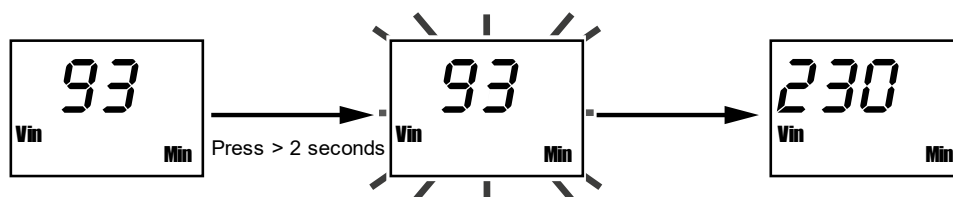

Display R.M.S. / PEAK input voltage parameters values:

- ⇒ To display PEAK input voltage values:
 - in Real-Time Mode, browse to V_{in} and press the Display Push-Button for more than 6 seconds
 - ✓ PEAK values initiated when:
 - ✓ Display shows "U_PEAK"
 - ✓ V_{in} starts flashing
- ⇒ To display the PEAK input voltage recorded data
 - browse until display shows "Press 2 sec for page 2"
- ⇒ To return to the R.M.S. standard values:
 - browse to V_{in} and press the Display Push-Button for more than 6 seconds
 - ✓ R.M.S. values initiated when:
 - ✓ Display shows "U_RMS"
 - ✓ V_{in} stops flashing

Troubleshooting

In case of an external error, the status indicator shows **Alarm**.

Error codes:

- (1) Err2 = Overtemperature protection primary side
- (2) Err4 = Overload protection
- (3) Err5 = Overtemperature protection secondary side
- (4) Err6 = Output overvoltage protection

If all errors are cleared, **Alarm** turns off and the PSCD returns to the previously selected display mode. In case of an output overload, this might last up to 18 seconds (due to Hiccup^{PLUS}-Mode)

Fig. 9-4 Error Codes

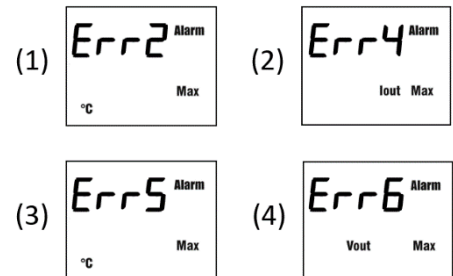

10. REMOTE ON / OFF FUNCTION

This feature enables the output to switch off by signal input.

A link between pin 15 and 16 turns the power supply off. Pin 15 is referenced to the (-) output voltage.

When multiple power supplies are connected in parallel, pin 15 and pin 16 are also allowed to be paralleled to control all units with the same switch or transistor.

Note: The remote ON/OFF function has no safety feature included.

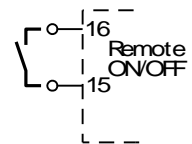
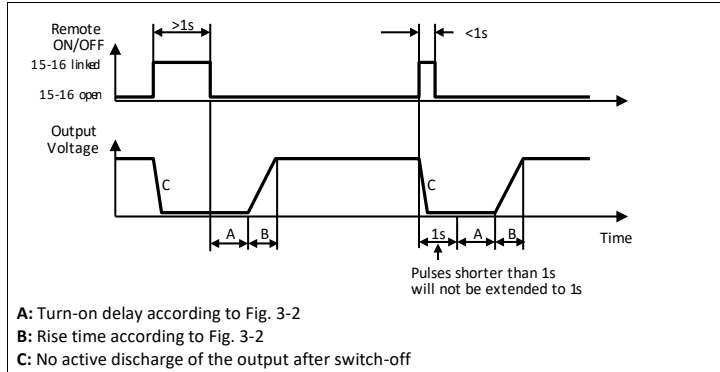

Fig. 10-1 The switch-off and the turn-on timing



11. "ALARM" RELAY CONTACT

This feature monitors the device and reports an overtemperature, output overload, output overvoltage or internal failure.

The Alarm relay signal output is synchronized with the Alarm LED and the contact is closed as soon as a failure is present. The voltage at the Alarm relay contacts must not exceed 60Vdc to earth.

Contact closes	As soon as a failure is present.
Contact opens	As soon as the failure disappears.
Contact ratings	Maximal 60Vdc 0.3A, 30Vdc 1A, 30Vac 0.5A, resistive load Minimal permissible load: 1mA at 5Vdc
Isolation voltage	See chapter "Dielectric Strength".

12. EFFICIENCY AND POWER LOSSES

		AC 100V	AC 120V	AC 230V	
Efficiency	typ.	93.6%	94.2%	95.6%	At 24V, 20A
	typ.	93.5%	94.1%	95.5%	At 24V, 24A (PowerBoost)
Average efficiency	typ.	93.2%	93.8%	95.0%	25% at 5A, 25% at 10A, 25% at 15A, 25% at 20A
Power losses	typ.	1W	1W	1.5W	in "Remote OFF" mode
	typ.	3.2W	3W	2.7W	At 24V, 0A
	typ.	17.2W	14.6W	12.8W	At 24V, 10A
	typ.	32.8W	29.6W	22.1W	At 24V, 20A
	typ.	40.0W	36.1W	27.1W	At 24V, 24A (PowerBoost)

The average efficiency is an assumption for a typical application where the power supply is loaded with 25% of the nominal load for 25% of the time, 50% of the nominal load for another 25% of the time, 75% of the nominal load for another 25% of the time and with 100% of the nominal load for the rest of the time.

Fig. 12-1 Efficiency vs. output current at 24V, typ.

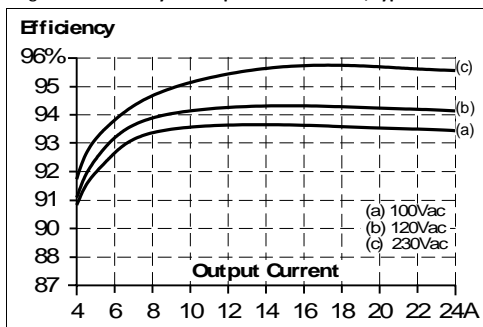

Fig. 12-2 Losses vs. output current at 24V, typ.

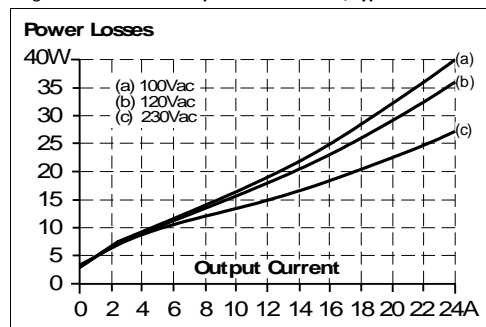

Fig. 12-3 Efficiency vs. input voltage at 24V, 20A, typ.

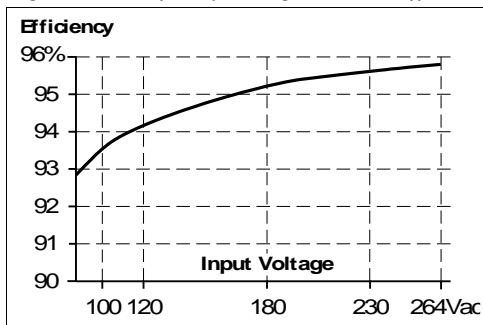
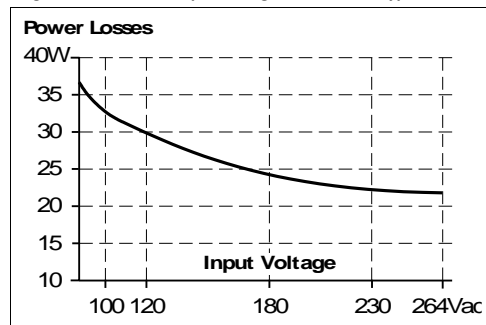
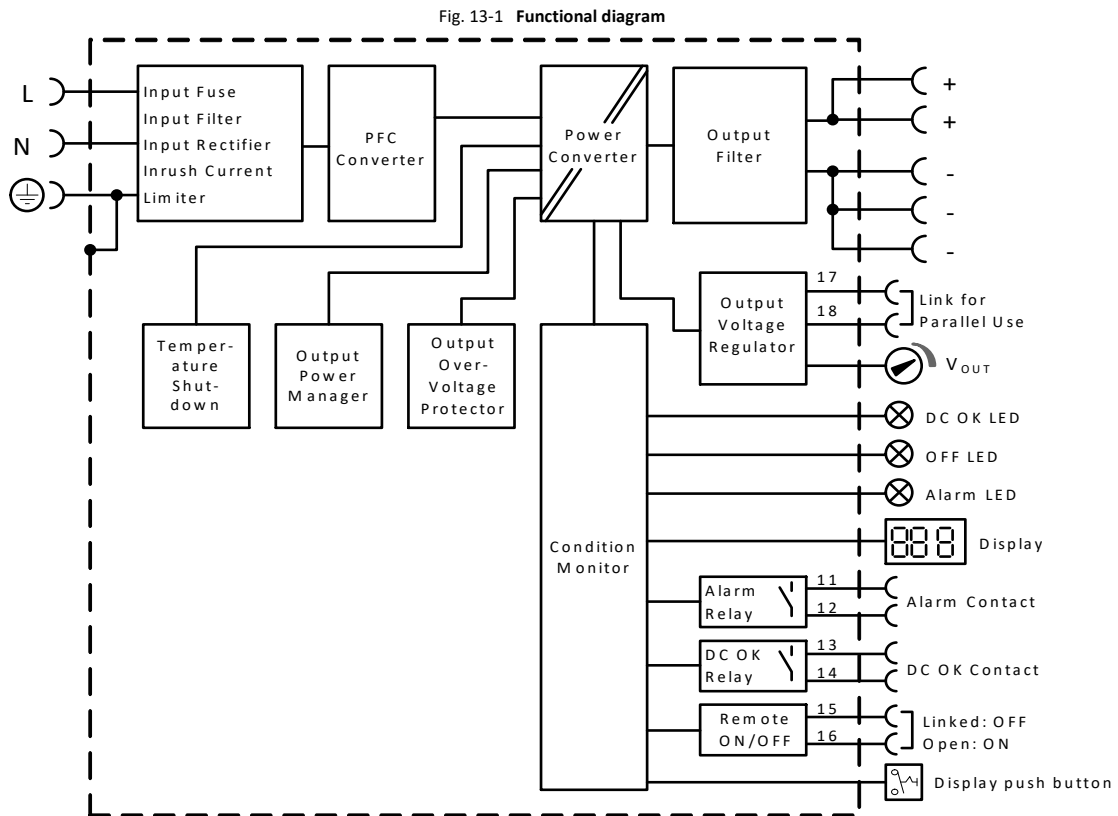

Fig. 12-4 Losses vs. input voltage at 24V, 20A, typ.



13. FUNCTIONAL DIAGRAM



14. FRONT SIDE AND USER ELEMENTS

Fig. 14-1 Front side

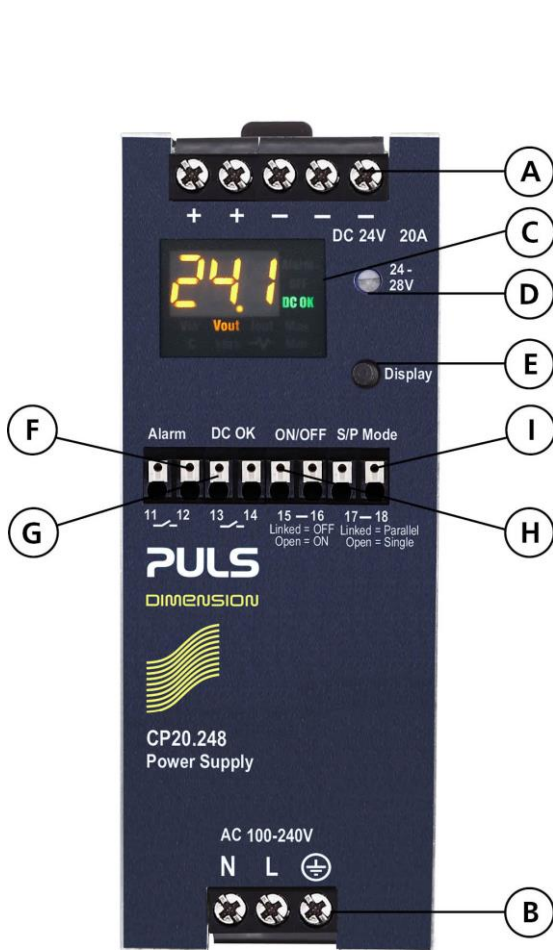

- A Output Terminals**
Three terminals for the negative and two terminals for the positive pole. Poles are internally connected.
+ Positive output
- Negative (return) output
- B Input Terminals**
L Phase (Line) input
N Neutral conductor input
⊕ PE (Protective Earth) input
- C Power Supply Condition Display**
See description below
- D Output Voltage Adjustment Potentiometer**
- E Display Push-Button**
This Push-Button can be used to navigate through the display menus and to select either the “Real-time Mode” or the “Recorded Data Mode”.
- F Alarm Relay Contact**
The alarm relay contact reports an overtemperature, output overload, output overvoltage or internal failure. The Alarm relay contact is synchronized with the Alarm LED of the power supply condition display.
See chapter “Alarm Relay Contact” for details.
- G DC OK Relay Contact**
This feature monitors the output voltage on the output terminals of a running power supply. The DC OK relay contact is synchronized with the DC OK LED of the power supply condition display.
See chapter “DC OK Relay Contact” for details.
- H Remote ON/OFF Input**
Link pin 15 and 16 to turn the power supply off.
See chapter “Remote ON / OFF Function” for details.
- I “Parallel Use” “Single Use” Link**
Link the two terminal poles when power supplies are connected in parallel. In order to achieve a sharing of the load current between the individual power supplies, the “parallel use” regulates the output voltage in such a manner that the voltage at no load is approx. 4% higher than at nominal load.

Fig. 14-2 Power Supply Condition Display

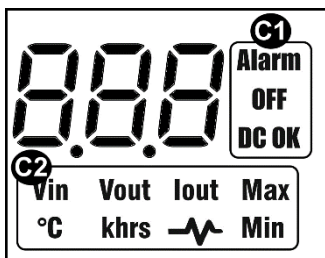

C1 Status Indicator: Alarm, OFF, DC OK

Alarm: The red Alarm LED reports overtemperature, output overload, output overvoltage is integrated in the power supply condition display.

OFF: The yellow OFF LED reports that the output has been switched off due to the remote ON/OFF signal and is integrated in the power supply condition display.

DC OK: The green DC OK LED reports an output above 22V of a running device

C2 Denomination Fields: Vin, Vout, Iout, °C, Transients and khrs

The symbol  stands for transient events

See chapter “Power Supply Condition Display” for details.

15. TERMINALS AND WIRING

The terminals are IP20 Finger safe constructed and suitable for field- and factory wiring.

	Input	Output	Signal Terminals
Type	Screw Terminal	Screw Terminal	Push-in Terminal
Solid wire	max. 6mm ²	max. 6mm ²	max. 1.5mm ²
Stranded wire	max. 4mm ²	max. 4mm ²	max. 1.5mm ²
American Wire Gauge	AWG 20-10	AWG 20-10	AWG 24-16
Max. wire diameter (including ferrules)	2.8mm	2.8mm	1.6mm
Recommended tightening torque	max. 1Nm	Max. 1Nm	-
Wire stripping length	7mm	7mm	8mm
Screwdriver	3.5mm slotted or cross-head No 2	3.5mm slotted or cross-head No 2	3mm slotted to open the spring

Instructions:

- a) Use appropriate copper cables that are designed for minimum operating temperatures of:
 - +60°C for ambient up to +45°C and
 - +75°C for ambient up to +60°C minimum
 - +90°C for ambient up to +70°C minimum.
- b) Follow national installation codes and installation regulations!
- c) Ensure that all strands of a stranded wire enter the terminal connection!
- d) Do not use the unit without PE connection.
- e) Unused terminal compartments should be securely tightened.
- f) Ferrules are allowed.

Daisy chaining:

Daisy chaining (jumping from one power supply output to the next) is not allowed. Use a separate distribution terminal block as shown in Fig. 15-1.

Fig. 15-1 Using distribution terminals

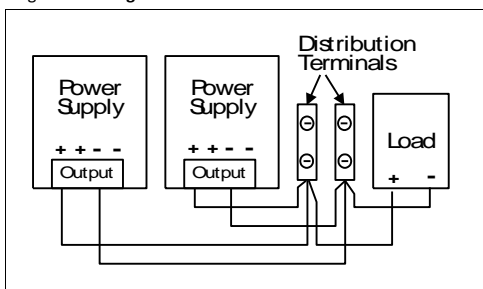

16. LIFETIME EXPECTANCY

The Lifetime expectancy shown in the table indicates the minimum operating hours (service life) and is determined by the lifetime expectancy of the built-in electrolytic capacitors. Lifetime expectancy is specified in operational hours and is calculated according to the capacitor's manufacturer specification. The manufacturer of the electrolytic capacitors only guarantees a maximum life of up to 15 years (131 400h). Any number exceeding this value is a calculated theoretical lifetime which can be used to compare devices.

	AC 100V	AC 120V	AC 230V	
Lifetime expectancy	111 000h	130 000h	157 000h	At 24V, 10A and +40°C
	313 000h	368 000h	443 000h	At 24V, 10A and +25°C
	40 000h	51 000h	88 000h	At 24V, 20A and +40°C
	113 000h	145 000h	248 000h	At 24V, 20A and +25°C
	23 000h	33 000h	63 000h	At 24V, 24A and +40°C
	66 000h	93 000h	178 000h	At 24V, 24A and +25°C

17. MTBF

MTBF stands for **Mean Time Between Failures**, which is calculated according to statistical device failures, and indicates reliability of a device. It is the statistical representation of the likelihood of a unit to fail and does not necessarily represent the life of a product.

The MTBF figure is a statistical representation of the likelihood of a device to fail. A MTBF figure of e.g. 1 000 000h means that statistically one unit will fail every 100 hours if 10 000 units are installed in the field. However, it cannot be determined if the failed unit has been running for 50 000h or only for 100h.

For these types of units the MTTF (**Mean Time To Failure**) value is the same value as the MTBF value.

	AC 100V	AC 120V	AC 230V	
MTBF SN 29500, IEC 61709	331 000h	349 000h	463 000h	At 24V, 20A and +40°C
	626 000h	659 000h	840 000h	At 24V, 20A and +25°C
MTBF MIL HDBK 217F	180 000h	185 000h	216 000h	At 24V, 20A and +40°C; Ground Benign GB40
	242 000h	249 000h	296 000h	At 24V, 20A and +25°C; Ground Benign GB25
	38 000h	40 000h	48 000h	At 24V, 20A and +40°C; Ground Fixed GF40
	50 000h	52 000h	63 000h	At 24V, 20A and +25°C; Ground Fixed GF25

18. EMC

The EMC behavior of the device is designed for applications in industrial environment as well as in residential, commercial and light industry environments.

The device complies with EN 61000-6-1, EN 61000-6-2, EN 61000-6-3, EN IEC 61000-6-8, EN 61000-6-4, EN 61000-3-2 and EN 61000-3-3.

The device complies with FCC Part 15 rules. Operation is subjected to following two conditions: (1) this device may not cause harmful interference, and (2) this device must accept any interference received, including interference that may cause undesired operation.

No restrictions apply for DC power ports in industrial, light-industrial and commercial environments. For DC power ports in residential environments no restrictions apply with a maximum DC output line length of 25m.

EMC Immunity	Power lines and housing			
Electrostatic discharge	EN 61000-4-2	Contact discharge	8kV	Criterion A
		Air discharge	15kV	Criterion A
Electromagnetic RF field	EN 61000-4-3	80MHz-2.7GHz	20V/m	Criterion A
		2.7-6GHz	10V/m	Criterion A
Fast transients (Burst)	EN 61000-4-4	Input lines	4kV	Criterion A
		Output lines	2kV	Criterion A
Surge voltage on input	EN 61000-4-5	L → N	2kV	Criterion A
		N → PE	4kV	Criterion A
		L → PE	4kV	Criterion A
Surge voltage on output	EN 61000-4-5	+ → -	1kV	Criterion A
		+ → PE	2kV	Criterion A
		- → PE	2kV	Criterion A
Conducted disturbance	EN 61000-4-6	0.15-80MHz	20V	Criterion A
Mains voltage dips	EN 61000-4-11	0% of 100Vac	0Vac, 20ms	Criterion A
		40% of 100Vac	40Vac, 200ms	Criterion C
		70% of 100Vac	70Vac, 500ms	Criterion A
		0% of 120Vac	0Vac, 20ms	Criterion A
		40% of 120Vac	48Vac, 200ms	Criterion C
		70% of 120Vac	84Vac, 500ms	Criterion A
		0% of 200Vac	0Vac, 20ms	Criterion A
40% of 200Vac	80Vac, 200ms	Criterion A		
70% of 200Vac	140Vac, 500ms	Criterion A		
Voltage interruptions	EN 61000-4-11	0V	5000ms	Criterion C
Powerful transients	VDE 0160	Over entire load range	750V, 0.3ms	Criterion A

EMC Immunity	Signal and communication lines			
Fast transients (Burst)	EN 61000-4-4	Signals with coupling clamp	2kV	Criterion A
Surge voltage	EN 61000-4-5	DC OK, Alarm contact → PE	1kV	Criterion A
Conducted disturbance	EN 61000-4-6	0.15-80MHz	20V	Criterion A

Performance criterions:

A: Device shows normal operation behavior within the defined limits.

C: Temporary loss of function is possible. The device may shut-down and restarts by itself. No damage or hazards for the device will occur.

EMC Emission

Conducted emission input lines	EN 55011, EN 55032, FCC Part 15, CISPR 11, CISPR 32	Class B
Conducted emission output lines	IEC/CISPR 16-1-2, IEC/CISPR 16-2-1	EN IEC 61000-6-3 limits for DC power ports fulfilled for a maximum DC output line length of 25m. EN IEC 61000-6-8 limits for DC power ports fulfilled without restrictions.
Radiated emission	EN 55011, EN 55032, CISPR 11, CISPR 32	Class B for 200-240 Vac Class A for 100-120 Vac
Harmonic input current	EN 61000-3-2 - Class A equipment EN 61000-3-2 - Class C equipment	Fulfilled Fulfilled in the load range from 8 to 24A
Voltage fluctuations, flicker	EN 61000-3-3	Fulfilled, tested with non-pulsing constant current loads.

Switching Frequencies

PFC converter	100kHz	Fixed frequency
Main converter	80kHz to 140kHz	Output load dependent
Auxiliary converter	60kHz	Fixed frequency
Microcontroller	8MHz, 24MHz, 48MHz	The device utilizes in total 3 microcontrollers

19. ENVIRONMENT

Operational temperature	-25°C to +70°C	The operational temperature is the ambient or surrounding temperature and is defined as the air temperature 2cm below the device.
Storage temperature	-40°C to +85°C	For storage and transportation
Output derating	12.5W/K 1.33A/1000m or 5K/1000m The derating is not hardware controlled. The user has to take care by him-self to stay below the derated current limits in order not to overload the unit.	Between +60°C and +70°C For altitudes >2000m, see Fig. 19-2
Humidity	5 to 95% r.h.	According to IEC 60068-2-30
Atmospheric pressure	110-54kPa	See Fig. 19-2 for details
Altitude	0 to 2000m 2000 to 5000m	Without any restrictions Reduce output power or ambient temperature, see Fig. 19-2 for details
Overvoltage category	II	According to IEC 60664-1, for altitudes up to 5000m
Impulse withstand voltage	4kV (according to overvoltage category III)	Input to PE According to IEC 60664-1, for altitudes up to 2000m
Degree of pollution	2	According to IEC 60664-1, not conductive
Vibration sinusoidal	2-17.8Hz: ±1.6mm 17.8-500Hz: 2g 2 hours / axis	According to IEC 60068-2-6
Shock	30g 6ms, 20g 11ms 3 bumps / direction 18 bumps in total Shock and vibration is tested in combination with DIN rails according to EN 60715 with a height of 15mm and a thickness of 1.3mm and standard orientation.	According to IEC 60068-2-27

Fig. 19-1 Output power vs. ambient temp.

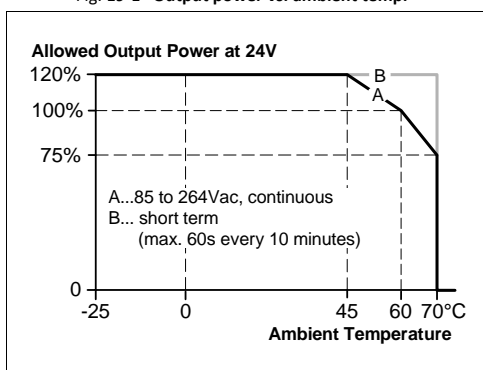
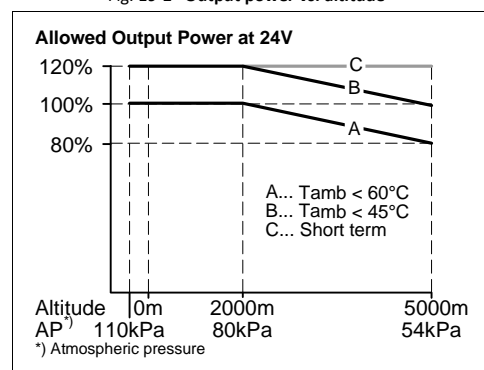

Fig. 19-2 Output power vs. altitude



20. SAFETY AND PROTECTION FEATURES

Insulation resistance	min.	500MΩ	At delivered condition between input and output, measured with 500Vdc
	min.	500MΩ	At delivered condition between input and PE, measured with 500Vdc
	min.	500MΩ	At delivered condition between output and PE, measured with 500Vdc
	min.	500MΩ	At delivered condition between output and DC OK or Alarm contacts, measured with 500Vdc
PE resistance	max.	0.1Ω	Resistance between PE terminal and the housing in the area of the DIN rail mounting bracket.
Output overvoltage protection	typ.	30.5Vdc	In case of an internal defect, a redundant circuit limits the maximum output voltage to 32V. The output switches off and performs three restart attempts. If the failure continues, the output shuts down. Cycle input power to reset.
	max.	32Vdc	
Class of protection		I	According to IEC 61140 A PE (Protective Earth) connection is required
Degree of protection		IP 20	According to EN/IEC 60529
Overtemperature protection		Included	Output shuts down with automatic restart. Temperature sensors are installed on critical components inside the unit and turn the unit off in safety critical situations, which can happen e.g. when ambient temperature is too high, ventilation is obstructed or the derating requirements are not followed. There is no correlation between the operating temperature and turn-off temperature since this is dependent on input voltage, load and installation methods.
Input transient protection		MOV (Metal Oxide Varistor)	For protection values see chapter "EMC".
Internal input fuse		Included	Not user replaceable slow-blow high-braking capacity fuse
Touch current (leakage current)	typ.	0.12mA / 0.31mA	At 100Vac, 50Hz, TN-,TT-mains / IT-mains
	typ.	0.18mA / 0.45mA	At 120Vac, 60Hz, TN-,TT-mains / IT-mains
	typ.	0.30mA / 0.76mA	At 230Vac, 50Hz, TN-,TT-mains / IT-mains
	max.	0.16mA / 0.38mA	At 110Vac, 50Hz, TN-,TT-mains / IT-mains
	max.	0.23mA / 0.55mA	At 132Vac, 60Hz, TN-,TT-mains / IT-mains
	max.	0.39mA / 0.94mA	At 264Vac, 50Hz, TN-,TT-mains / IT-mains

21. DIELECTRIC STRENGTH

The output voltage is floating and has no ohmic connection to the ground.

The output is insulated to the input by a double or reinforced insulation.

Type and routine tests are conducted by the manufacturer. Field tests may be conducted in the field using the appropriate test equipment which applies the voltage with a slow ramp (2s up and 2s down). Connect all input-terminals together as well as all output poles before conducting the test. When testing, set the cut-off current settings to the value in the table below.

We recommend that either the + pole or the – pole shall be connected to the protective earth system. This helps to avoid situations in which a load starts unexpectedly or cannot be switched off when unnoticed earth faults occur.

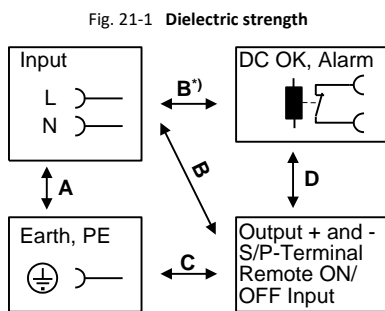

		A	B	C	D
Type test	60s	2500Vac	3000Vac	1000Vac	500Vac
Routine test	5s	2500Vac	2500Vac	500Vac	500Vac
Field test	5s	2000Vac	2000Vac	500Vac	500Vac
Cut-off current setting for field test		> 10mA	> 10mA	> 20mA	> 1mA





B^{*)}

When testing ensure that the maximal voltage between DC OK and the output and DC-Alarm and the output is not exceeded (column D). We recommend connecting DC OK and Alarm pins and the output pins together when performing the test.

22. APPROVED, FULFILLED OR TESTED STANDARDS

IEC 61010		CB Scheme Certificate IEC 61010-2-201 Electrical Equipment for Measurement, Control and Laboratory Use - Particular requirements for control equipment
UL 61010-2-201		UL Certificate Listed equipment for category NMTR - Electrical Equipment for Measurement, Control and Laboratory Use - Particular requirements for control equipment Applicable for US and Canada E-File: E198865

23. REGULATORY PRODUCT COMPLIANCE

EU Declaration of Conformity		EU Declaration of Conformity Trade conformity assessment for Europe The CE mark indicates conformance with the European - RoHS directive, - EMC directive and the - Low-voltage directive (LVD)
REACH Regulation (EU)		
WEEE Regulation		Manufacturer's Declaration EU Regulation on Waste Electrical and Electronic Equipment Registered as business to business (B2B) products. EU Regulation 2012/19/EU
RoHS (China RoHS 2)		

24. PHYSICAL DIMENSIONS AND WEIGHT

Width	48mm
Height	124mm
Depth	127mm
	The DIN rail depth must be added to the unit depth to calculate the total required installation depth.
Weight	835g
DIN rail	Use 35mm DIN rails according to EN 60715 or EN 50022 with a height of 7.5 or 15mm.
Housing material	Body: aluminium alloy Cover: zinc-plated steel
Installation clearances	See chapter 2

Fig. 24-1 Front view

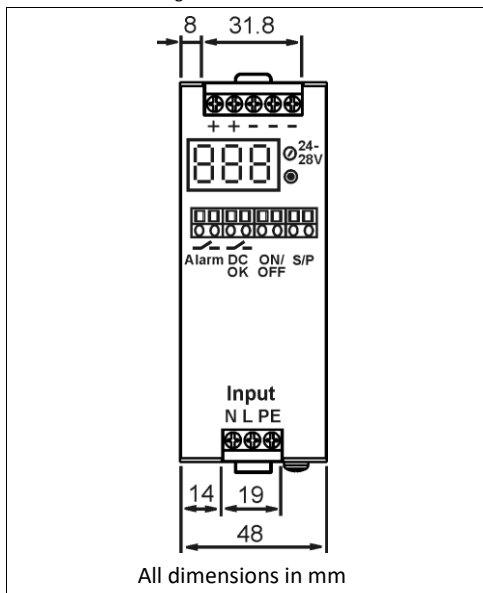
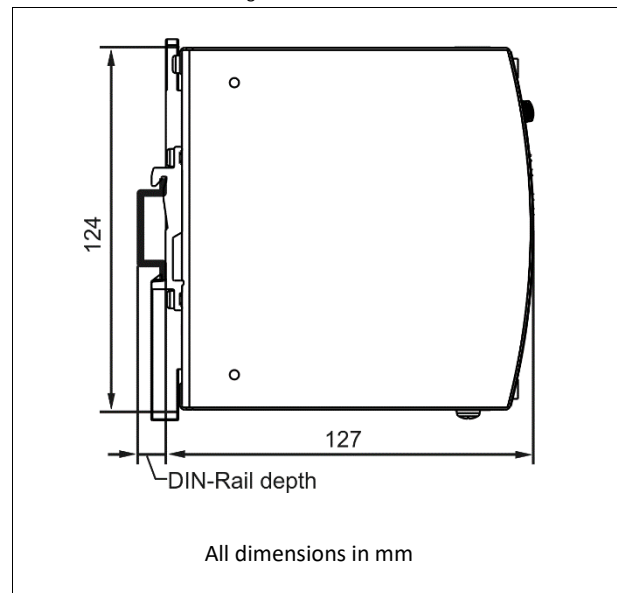

Fig. 24-2 Side view



25. ACCESSORIES

25.1. ZM10.WALL – WALL/PANEL MOUNT BRACKET

This bracket is used to mount the devices on a wall/panel without utilizing the DIN rail. The bracket can be mounted without detaching the DIN rail brackets from the power supply. Product for illustration purposes only.

Fig. 25-1 Isometric view

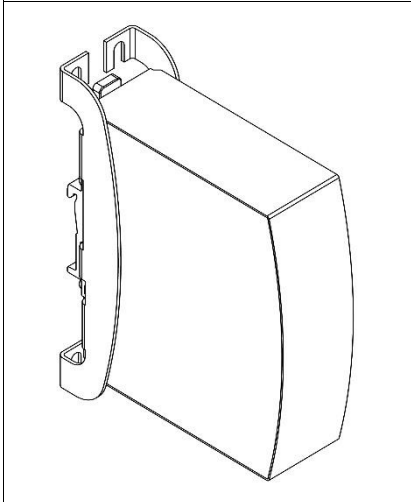

Fig. 25-2 Isometric view

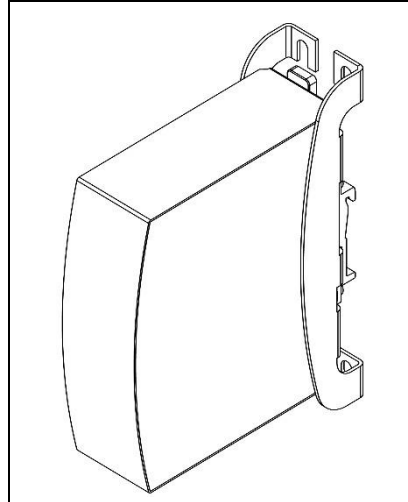

Fig. 25-3 Isometric view

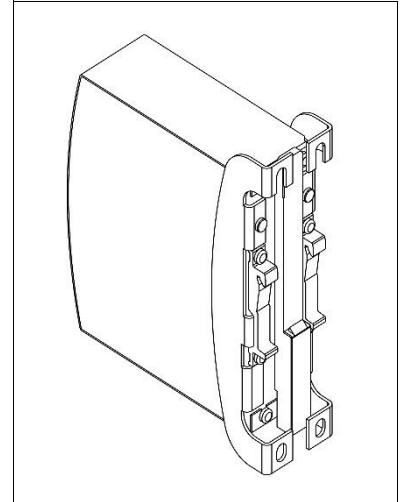

Fig. 25-4 Wall/panel mounting, front view

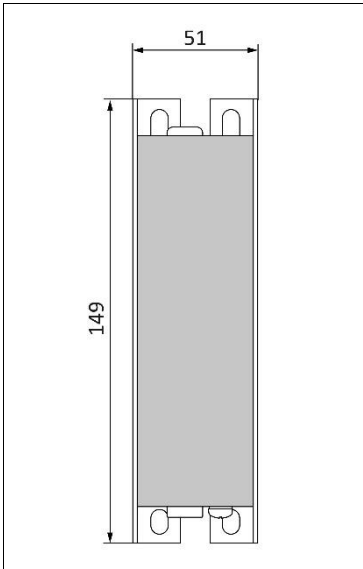

Fig. 25-5 Hole pattern for wall mounting

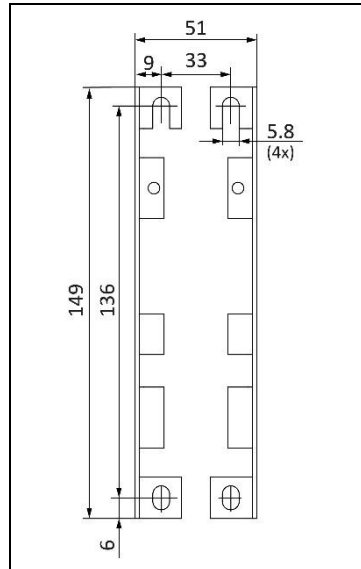
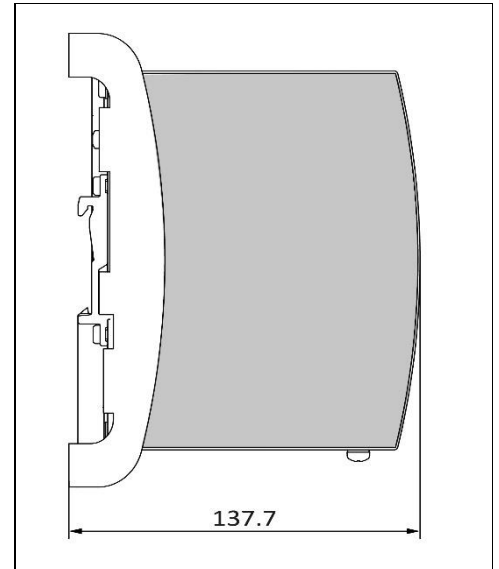
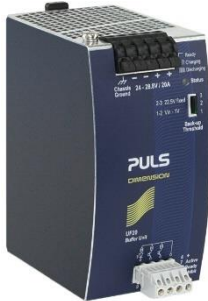

Fig. 25-6 Wall/panel mounting, side view



25.2. UF20.241 BUFFER MODULE



The UF20.241 buffer module is a supplementary device for DC 24V power supplies. It delivers power to bridge typical mains failures or extends the hold-up time after the AC power is turned off.

When the power supply provides a sufficient voltage, the buffer module stores energy in the integrated electrolytic capacitors. When the mains voltage is lost, the stored energy is released to the DC-bus in a regulated process.

The buffer module can be added in parallel to the load circuit at any given point and does not require any control wiring.

One buffer module can deliver 20A additional current and can be added in parallel to increase the output ampacity or the hold-up time.

25.3. YR40.241 - REDUNDANCY MODULE



The YR40.241 is a dual redundancy module, which can be used to build 1+1 or N+1 redundant system.

The device is equipped with two 20A nominal input channels, which are individually decoupled by utilizing MOSFET technology. The output can be loaded with a nominal 40A continuous current.

Using MOSFETs instead of diodes reduces heat generation, losses and voltage drop between input and output. Due to these advantages, the unit is very narrow and only requires 36mm width on the DIN rail.

The device does not require an additional auxiliary voltage and is self-powered even in case of a short circuit across the output.

A feature of this redundancy module is a special circuit, which keeps the losses and temperature low, even at overload and short circuit conditions up to 65A continuous current.

See chapter "Parallel Use for Redundancy" for wiring information.

25.4. YR40.242 - REDUNDANCY MODULE



The YR40.242 is a dual redundancy module, which can be used to build 1+1 or N+1 redundant system.

The device is equipped with two 20A nominal input channels, which are individually decoupled by utilizing MOSFET technology. The output can be loaded with a nominal 40A continuous current.

Using MOSFETs instead of diodes reduces heat generation, losses and voltage drop between input and output. Due to these advantages, the unit is very narrow and only requires 36mm width on the DIN rail.

The device does not require an additional auxiliary voltage and is self-powered even in case of a short circuit across the output. It requires suitable power supplies on the input, where the sum of the continuous short circuit current stays below 26A. This is typically achieved when the power supplies are featured with an intermittent overload behavior (Hiccup Mode).

See chapter "Parallel Use for Redundancy" for wiring information.

25.5. YR40.245 - REDUNDANCY MODULES



The YR40.245 is a 40A single channel redundancy module, which is equipped with a plug connector on the output. The plug connector allows replacing the power supply or the redundancy module while the system is running. The plug connector prevents the output wires from touching and creating a short the load circuit.

The input of the device is decoupled by utilizing MOSFET technology.

Using MOSFETs instead of diodes reduces heat generation, losses and voltage drop between input and output. Due to these advantages, the unit is very narrow and only requires 46mm width on the DIN rail.

The device does not require an additional auxiliary voltage and is self-powered even in case of a short circuit across the output. It requires a suitable power supply on the input, where the continuous short circuit current stays below 22A. This is typically achieved when the power supply is featured with an intermittent overload behavior (Hiccup Mode).

See chapter “Parallel Use for Redundancy” for wiring information.

26. APPLICATION NOTES

26.1. PEAK CURRENT CAPABILITY

The unit can deliver peak currents (up to several milliseconds) which are higher than the specified short term currents.

This helps to start current demanding loads. Solenoids, contactors and pneumatic modules often have a steady state coil and a pick-up coil. The inrush current demand of the pick-up coil is several times higher than the steady-state current and usually exceeds the nominal output current. The same situation applies when starting a capacitive load.

The peak current capability also ensures the safe operation of subsequent circuit breakers of load circuits. The load branches are often individually protected with circuit breakers or fuses. In case of a short or an overload in one branch circuit, the fuse or circuit breaker need a certain amount of overcurrent to open in a timely manner. This avoids voltage loss in adjacent circuits.

The extra current (peak current) is supplied by the power converter and the built-in large sized output capacitors of the power supply. The capacitors get discharged during such an event, which causes a voltage dip on the output. The following three examples show typical voltage dips for resistive loads:

Fig. 26-1 40A peak current for 50ms, typ.
(2x the nominal current)

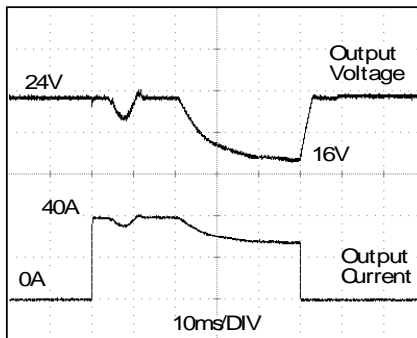

Fig. 26-2 100A peak current for 5ms, typ.
(5x the nominal current)

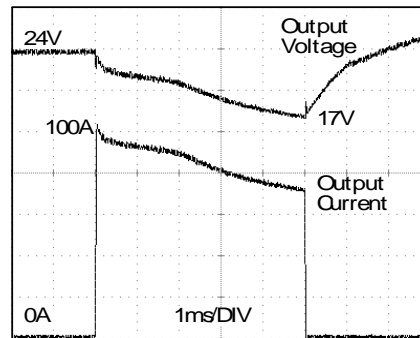
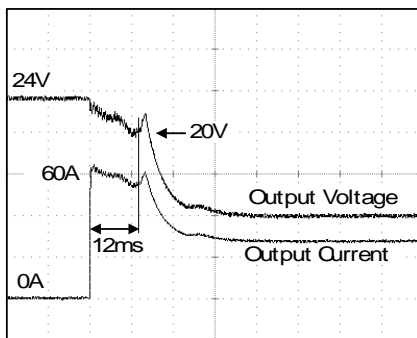

Fig. 26-3 60A peak current for 12ms, typ.
(3x the nominal current)



Please note: The DC OK relay might trigger when the voltage dips more than 10% for longer than 1ms.

Peak current voltage dips	typ.	from 24V to 16V	At 40A for 50ms, resistive load
	typ.	from 24V to 21V	At 100A for 2ms, resistive load
	typ.	from 24V to 17V	At 100A for 5ms, resistive load

26.2. OUTPUT CIRCUIT BREAKERS

Standard miniature circuit breakers (MCB's or UL 1077 circuit breakers) are commonly used for AC-supply systems and may also be used on 24V branches.

MCB's are designed to protect wires and circuits. If the ampere value and the characteristics of the MCB are adapted to the wire size that is used, the wiring is considered as thermally safe regardless of whether the MCB opens or not.

To avoid voltage dips and under-voltage situations in adjacent 24V branches which are supplied by the same source, a fast (magnetic) tripping of the MCB is desired. A quick shutdown within 10ms is necessary corresponding roughly to the ride-through time of PLC's. This requires power supplies with high current reserves and large output capacitors. Furthermore, the impedance of the faulty branch must be sufficiently small in order for the current to actually flow. The best current reserve in the power supply does not help if Ohm's law does not permit current flow. The following table has typical test results showing which B- and C-Characteristic MCBs magnetically trip depending on the wire cross chapter and wire length.

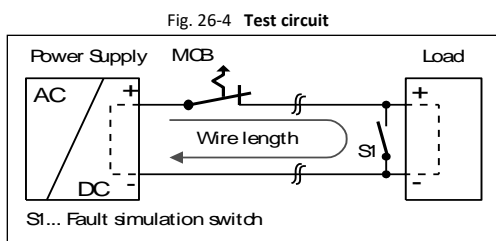

Maximal wire length^{*)} for a fast (magnetic) tripping:

	0.75mm ²	1.0mm ²	1.5mm ²	2.5mm ²
C-2A	31 m	37 m	63 m	98 m
C-3A	28 m	34 m	51 m	78 m
C-4A	18 m	25 m	38 m	58 m
C-6A	9 m	11 m	18 m	26 m
C-8A	6 m	7 m	12 m	14 m
C-10A	4 m	6 m	11 m	13 m
C-13A	2 m	2 m	4 m	7 m
B-6A	23 m	28 m	46 m	66 m
B-10A	11 m	14 m	19 m	32 m
B-13A	7 m	11 m	16 m	29 m
B-16A	5 m	6 m	8 m	15 m
B-20A	1 m	1 m	2 m	4 m
B-25A				1 m

*) Don't forget to consider twice the distance to the load (or cable length) when calculating the total wire length (+ and - wire).

26.3. CHARGING OF BATTERIES

The power supply can be used to charge lead-acid or maintenance-free batteries. Two 12V SLA or VRLA batteries are needed in series connection.

Instructions for charging batteries:

- Use only matched batteries when putting 12V types in series.
- Ensure that the ambient temperature of the power supply stays below 40°C.
- Use a 30A or 32A circuit breaker or a blocking diode between the power supply and the battery.
- Ensure that the output current of the power supply is below the allowed charging current of the battery.
- The return current to the power supply is typically 3.5mA. This return current can discharge the battery when the power supply is switched off except in case a blocking diode is utilized.
- Set the device into "Parallel Use" mode and adjust the output voltage, measured at no load and at the battery end of the cable, very precisely to the end-of-charge voltage of 27.8V at 10°C, 27.5V at 20°C, 27.15V at 30°C and 26.8V at 40°C ambient temperature.

26.4. SERIES OPERATION

Devices of the same type can be connected in series for higher output voltages. It is possible to connect as many units in series as needed, providing the sum of the output voltage does not exceed 150Vdc. Voltages with a potential above 60Vdc must be installed with a protection against touching.

Avoid return voltage (e.g. from a decelerating motor or battery) which is applied to the output terminals.

Keep an installation clearance of 15mm (left / right) between two power supplies and avoid installing the power supplies on top of each other. Do not use power supplies in series in mounting orientations other than the standard mounting orientation.

Pay attention that leakage current, EMI, inrush current, harmonics will increase when using multiple devices.

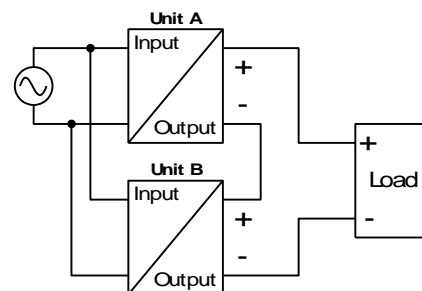

26.5. PARALLEL USE TO INCREASE OUTPUT POWER

Devices can be paralleled to increase the output power. The output voltage of all power supplies shall be adjusted to the same value ($\pm 100\text{mV}$) in "Single Use" mode with the same load conditions on all units, or the units can be left with the factory settings. After the adjustments, set the unit to "Parallel Use" mode, in order to achieve load sharing. The "Parallel Use" mode regulates the output voltage in such a manner that the voltage at no load is approx. 4% higher than at nominal load.

The ambient temperature is not allowed to exceed +60°C.

If more than three units are connected in parallel, a fuse or circuit breaker with a rating of 30A or 32A is required on each output. Alternatively, a diode or redundancy module can also be utilized.

Energize all units at the same time. It also might be necessary to cycle the input power (turn-off for at least five seconds), if the output was in overload or short circuits and the required output current is higher than the current of one unit.

Keep an installation clearance of 15mm (left / right) between two devices and avoid installing devices on top of each other. Do not use devices in parallel in mounting orientations other than the standard mounting orientation or in any other condition where a reduction of the output current is required (e.g. altitude).

Pay attention that leakage current, EMI, inrush current will increase when using multiple devices.

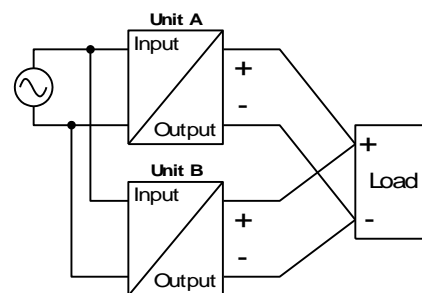

26.6. PARALLEL USE FOR REDUNDANCY

1+1 Redundancy:

Devices can be paralleled for redundancy to gain higher system availability. Redundant systems require a certain amount of extra power to support the load in case one device fails. The simplest way is to put two devices in parallel. This is called a 1+1 redundancy. In case one device fails, the other one is automatically able to support the load current without any interruption. It is essential to use a redundancy module to decouple devices from each other. This prevents that the defective unit becomes a load for the other device and the output voltage cannot be maintained any more.

1+1 redundancy allows ambient temperatures up to +70°C.

Pay attention that leakage current, EMI, inrush current, harmonics will increase when using multiple devices.

Recommendations for building redundant power systems:

- Use separate input fuses for each device.
- Use separate mains systems for each device whenever it is possible.
- Monitor the individual devices. Therefore, use the DC OK signal of the device.
- It is desirable to set the output voltages of all devices to the same value ($\pm 100\text{mV}$) or leave it at the factory setting.
- Set the devices into "Parallel Use" mode.

N+1 Redundancy:

Redundant systems for a higher power demand are usually built in a N+1 method. E.g. four devices, each rated for 20A are paralleled to build a 60A redundant system.

Pay attention that leakage current, EMI, inrush current, harmonics will increase when using multiple power supplies.

Keep an installation clearance of 15mm (left / right) between two power supplies and avoid installing the power supplies on top of each other.

Do not use devices in parallel in mounting orientations other than the standard mounting orientation or in any other condition, where a derating of the output current is required.

For N+1 redundancy the ambient temperature is not allowed to exceed +60°C.

Wiring examples for 1+1 and n+1 redundancy:

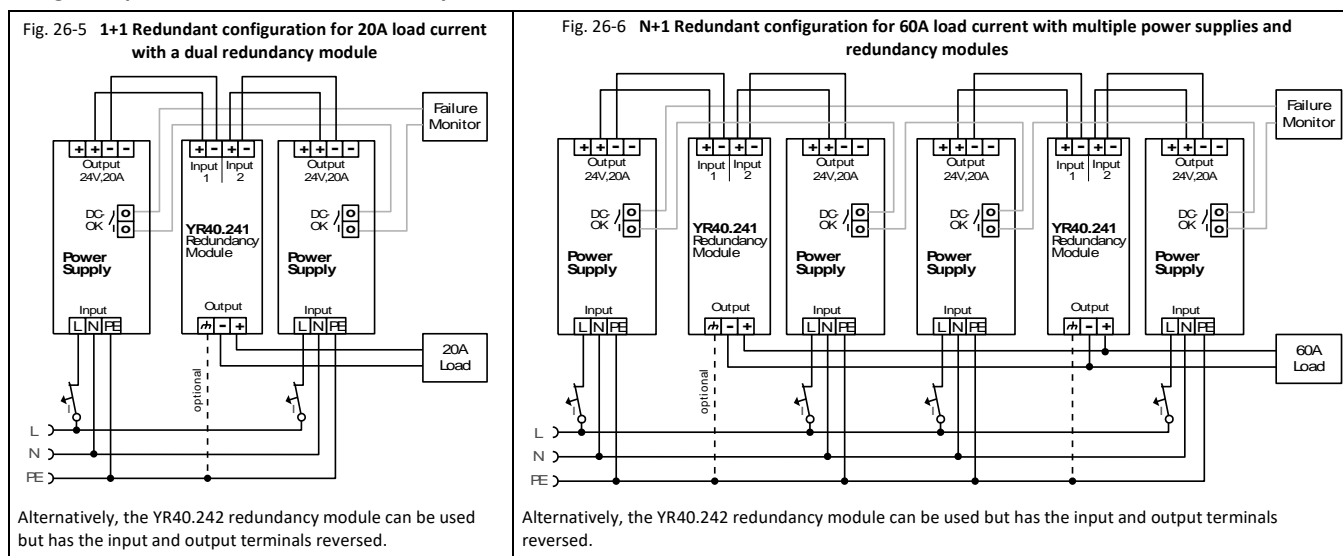

26.7. OPERATION ON TWO PHASES

The power supply can also be used on two-phases of a three-phase-system. Such a phase-to-phase connection is allowed as long as the supplying voltage is below 240V^{+10%}.

Ensure that the wire, which is connected to the N-terminal, is appropriately fused.

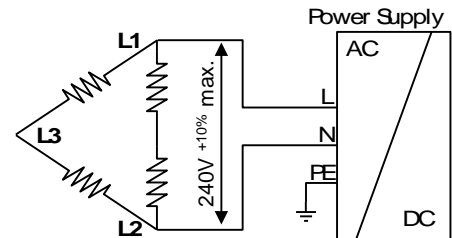

26.8. USE IN A TIGHTLY SEALED ENCLOSURE

When the device is installed in a tightly sealed enclosure, the temperature inside the enclosure will be higher than outside. In such situations, the inside temperature defines the ambient temperature for the device.

In the following test setup, the device is placed in the middle of the box, no other heat producing items are inside the box. The load is placed outside the box.

The temperature sensor inside the box is placed in the middle of the right side of the power supply with a distance of 1cm. The following measurement results can be used as a reference to estimate the temperature rise inside the enclosure.

	Case A	Case B
Enclosure size	180x180x165mm IP66 Box Rittal PK 9519 100, plastic	180x180x165mm IP66 Box Rittal PK 9519 100, plastic
Input voltage	230Vac	230Vac
Load	24V, 16A; (=80%)	24V, 20A; (=100%)
Temperature inside the box	46.8°C	51.2°C
Temperature outside the box	21.0°C	21.0°C
Temperature rise	25.8K	30.2K

26.9. MOUNTING ORIENTATION

Install the device onto a DIN rail with the input terminals on the bottom of the device.

The test environment is set up installing wiring ducts (depth: 80mm) with clearances seen in chapter 2.

Fig. 26-7
Mounting
Orientation A
(Standard
orientation)

