



POWER SUPPLY

- 2MOPP Safety Approved for Medical applications According to UL / IEC 60601-1
- EMC Tested for Medical Use According to 60601-1-2
- Quick-connect Spring-clamp Terminals
- AC 100-240V Wide-range Input
- Width only 39mm
- Efficiency up to 95.2%, Excellent Partial Load Efficiency
- 20% Output Power Reserves (PowerBoost)
- Safe Hiccup^{PLUS} Overload Mode
- Easy Fuse Breaking due to High Overload Peak Current
- Active Power Factor Correction (PFC)
- Minimal Inrush Current Surge
- Full Power Between -25°C and +60°C
- DC-OK Relay Contact
- 3 Years Limited Warranty

PRODUCT DESCRIPTION

The CP10.241-M1 is a DIN rail mountable single-phase-input power supply for industrial use and for use in medical equipment. It provides a stabilized and galvanically separated SELV/PELV output voltage.

The specialty of this power supply is the 2MOPP (two means of patient protection) safety approval for medical use and the fulfillment of the required EMC tests for professional healthcare facility and home healthcare environments.

The CP-Series is part of the DIMENSION power supply family. The most outstanding features of CP10.241-M1 are the high efficiency, advanced inrush current limitation, active PFC and the wide operational temperature range. The devices also offer PowerBoost: Power reserves of 20%, which may even be used continuously at temperatures up to +45°C.

High immunity to transients and power surges as well as low electromagnetic emission, a DC-OK relay contact and a large international approval package for a variety of applications makes this unit suitable for nearly every situation.

SHORT-FORM DATA

Output voltage	DC 24V	
Adjustment range	24 – 28V	Factory setting 24.1V
Output Current	10 – 8.6A	Up to +60°C ambient
	7.5 – 6.5A	At +70°C ambient
PowerBoost	Derate linearly between +60°C and +70°C	
	12A	Up to +45°C ambient
	Linear decrease to nominal power between +45°C and +60°C	
Input voltage AC	AC 100 - 240V	-15%/ +10%
Mains frequency	50 - 60Hz	±6%
AC Input current	2.15 / 1.13A	At 120 / 230Vac
Power factor	0.99 / 0.97	At 120 / 230Vac
Input inrush current	6 / 9A pk	At 40°C 120 / 230Vac
Input voltage DC	DC 110-150V	±20%
Input current DC	2.35A	At 110Vdc
Efficiency	93.6 / 95.2%	At 120 / 230Vac
Power losses	16.4 / 12.1W	At 120 / 230Vac
Hold-up time	37ms	
Temperature range	-25°C to +70°C	Continuous
Size (wxhxd)	39x124x117mm	Without DIN rail
Weight	620g	

ORDER NUMBERS

Power Supply	CP10.241-M1	Medical approved device
Accessory	ZM10.WALL	Wall mount bracket
	ZM12.SIDE	Side mount bracket

MAIN APPROVALS

For details and the complete approval list, see chapter 20





UL 60601-1

INDEX

Page	Page
1. Intended Use 3	21. Regulatory Product Compliance 20
2. Installation Instructions..... 3	22. Physical Dimensions and Weight 21
3. AC-Input 5	23. Accessories..... 22
4. DC-Input 6	23.1. ZM10.WALL - Wall/Panel Mount Bracket..... 22
5. Input Inrush Current..... 7	23.2. ZM12.SIDE - Side Mounting Bracket..... 23
6. Output 8	24. Application Notes..... 24
7. Hold-up Time..... 9	24.1. Peak Current Capability 24
8. DC-OK Relay Contact 10	24.2. Back-feeding Loads 25
9. Efficiency and Power Losses..... 11	24.3. External Input Protection 25
10. Lifetime Expectancy and MTBF 12	24.4. Output Circuit Breakers..... 25
11. Functional Diagram 12	24.5. Series Operation..... 26
12. Terminals and Wiring 13	24.6. Parallel Use to Increase Output Power 26
13. Front Side and User Elements 14	24.7. Parallel Use for Redundancy 26
14. EMC – According to Medical Standards 15	24.8. Inductive and Capacitive Loads 26
15. EMC – According to Generic Standards..... 16	24.9. Charging of Batteries..... 26
16. Environment..... 17	24.10. Operation on Two Phases 27
17. Safety Features..... 18	24.11. Use in a Tightly Sealed Enclosure 27
18. Protection Features..... 19	24.12. Mounting Orientations..... 28
19. Dielectric Strength..... 19	
20. Approved, Fulfilled or Tested Standards 20	

The information given in this document is correct to the best of our knowledge and experience at the time of publication. If not expressly agreed otherwise, this information does not represent a warranty in the legal sense of the word. As the state of our knowledge and experience is constantly changing, the information in this data sheet is subject to revision. We therefore kindly ask you to always use the latest issue of this document (available under www.pulspower.com). No part of this document may be reproduced or utilized in any form without our prior permission in writing.

TERMINOLOGY AND ABBREVIATIONS

PE and  symbol	PE is the abbreviation for Protective Earth and has the same meaning as the symbol  .
Earth, Ground	This document uses the term “earth” which is the same as the U.S. term “ground”.
t.b.d.	To be defined, value or description will follow later.
AC	Alternating Current
DC	Direct Current
AC 230V	A figure displayed with the AC or DC before the value represents a nominal voltage with standard tolerances (usually ±15%) included. E.g.: DC 12V describes a 12V battery disregarding whether it is full (13.7V) or flat (10V)
230Vac	A figure with the unit (Vac) at the end is a momentary figure without any additional tolerances included.
50Hz vs. 60Hz	As long as not otherwise stated, AC 100V and AC 230V parameters are valid at 50Hz mains frequency. AC 120V parameters are valid for 60Hz mains frequency.
may	A key word indicate flexibility of choice with no implied preference.
shall	A key word indicate a mandatory requirement.
should	A key word indicate flexibility of choice with a strongly preferred implementation.

1. INTENDED USE

This device is designed for installation in an enclosure and is intended for use in medical equipment.

Do not use this device in HF surgical equipment or similar apertures.

Do not use this device in equipment, where malfunction may cause severe personal injury or threaten human life.

2. INSTALLATION INSTRUCTIONS

WARNING Risk of electrical shock, fire, personal injury or death.

- Turn power off before working on the device. Protect against inadvertent re-powering.
- Do not open, modify or repair the unit.
- Use caution to prevent any foreign objects from entering the housing.
- Do not use in wet locations or in areas where moisture or condensation can be expected.
- Do not touch during power-on, and immediately after power-off. Hot surfaces may cause burns.

This device may only be installed and put into operation by qualified personnel.

This device does not contain serviceable parts. The tripping of an internal fuse is caused by an internal defect. If damage or malfunction should occur during installation or operation, immediately turn power off and send the device to the factory for inspection.

Install device in an enclosure providing protection against electrical, mechanical and fire hazards.

Install the device onto a DIN rail according to EN 60715 with the input terminals on the bottom of the device. Other mounting orientations require a reduction in output current.

Use shielded or unshielded cables, twisted or untwisted cables of any length. Make sure that the wiring is correct by following all local and national codes. Use appropriate copper cables that are designed for a minimum operating temperature of 90°C for ambient temperatures between +45°C and +60°C and 105°C for ambient temperatures up to +70°C. Ensure that all strands of a stranded wire enter the terminal connection.

The device is designed for pollution degree 2 areas in controlled environments. No condensation or frost is allowed.

The enclosure of the device provides a degree of protection of IP20. The enclosure does not provide protection against spilled liquids.

The isolation of the device is designed to withstand impulse voltages of overvoltage category III according to IEC 60664-1.

The device is designed as "Class of Protection I" equipment according to IEC 61140. Do not use without a proper PE (Protective Earth) connection.

The device is suitable to be supplied from TN, TT or IT mains networks. The continuous voltage between the input terminal and the PE potential must not exceed 300Vac.

The input can also be powered from batteries or similar DC sources. The continuous voltage between the supply voltage and the PE/ground potential must not exceed 375Vdc.

A disconnecting means shall be provided for the input of the device.

The device is designed for convection cooling and does not require an external fan. Do not obstruct airflow and do not cover ventilation grid!

The device is designed for altitudes up to 3000m.

Keep the following minimum installation clearances: 40mm on top, 20mm on the bottom, 5mm left and right side. Increase the 5mm to 15mm in case the adjacent device is a heat source. When the device is permanently loaded with less than 50%, the 5mm can be reduced to zero.

The device is designed, tested and approved for branch circuits up to 32A (IEC) and 30A (UL) without additional protection device. If an external fuse is utilized, do not use circuit breakers smaller than 6A B- or C-Characteristic to avoid a nuisance tripping of the circuit breaker.

The maximum surrounding air temperature is +70°C. The operational temperature is the same as the ambient or surrounding air temperature and is defined 2cm below the device.

The device is designed to operate in areas between 5% and 95% relative humidity.

Portable RF communication equipment should be used no closer than 30cm to the power supply or the power supply connection cables.

⚠ WARNING

Use of this equipment adjacent to or stacked with other equipment should be avoided because it could result in improper operation. If such use is necessary, this equipment and the other equipment should be observed to verify that they are operating normally.

3. AC-INPUT

AC input	Nom.	AC 100-240V	Suitable for TN-, TT- and IT mains networks
AC input range		85-264Vac	
		264-300Vac	For max. 500ms
Allowed voltage L or N to earth	Max.	300Vac	Continuous, IEC 62477-1
Input frequency	Nom.	50–60Hz	±6%
Turn-on voltage	Typ.	80Vac	Steady-state value, see Fig. 3-1
Shut-down voltage	Typ.	70Vac	Steady-state value, see Fig. 3-1
	Typ.	55Vac	Dynamic value (max. 250ms)
External input protection	See recommendations in chapter 24.3.		

		AC 100V	AC 120V	AC 230V	
Input current	Typ.	2.60A	2.15A	1.13A	At 24V, 10A, see Fig. 3-3
Power factor ^{*)}	Typ.	0.99	0.99	0.97	At 24V, 10A, see Fig. 3-4
Crest factor ^{**)}	Typ.	1.5	1.5	1.65	At 24V, 10A
Start-up delay	Typ.	300ms	290ms	240ms	See Fig. 3-2
Rise time	Typ.	30ms	30ms	30ms	At 24V, 10A const. current load, 0mF load capacitance, see Fig. 3-2
	Typ.	75ms	75ms	75ms	At 24V, 10A const. current load, 10mF load capacitance, see Fig. 3-2
Turn-on overshoot	Max.	200mV	200mV	200mV	See Fig. 3-2
External input protection					

*) The power factor is the ratio of the true (or real) power to the apparent power in an AC circuit.

***) The crest factor is the mathematical ratio of the peak value to RMS value of the input current waveform.

Fig. 3-1 Input voltage range

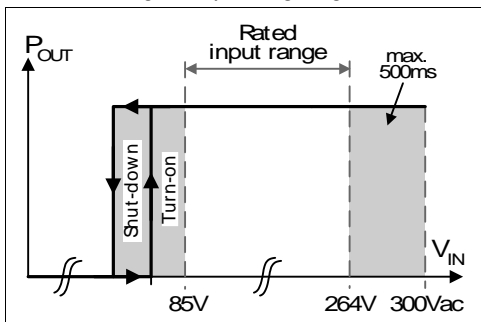

Fig. 3-2 Turn-on behaviour, definitions

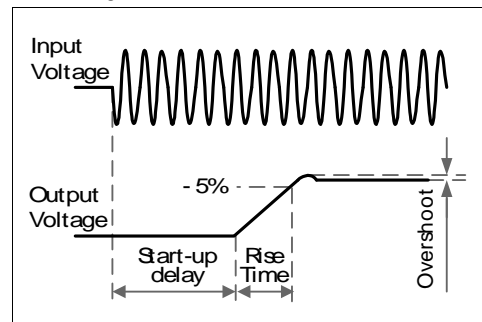

Fig. 3-3 Input current vs. output current at 24V output voltage

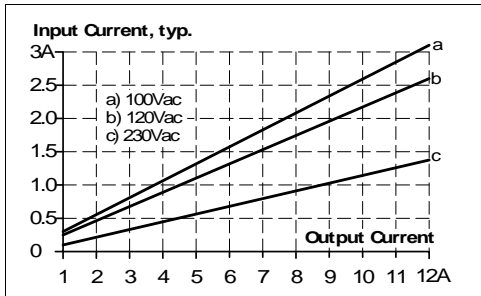
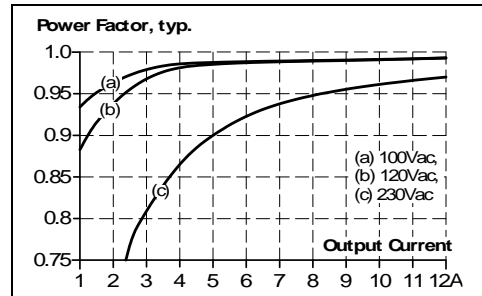

Fig. 3-4 Power factor vs. output current at 24V output voltage



4. DC-INPUT

DC input	Nom.	DC 110-150V ±20%	
DC input range		88-180Vdc	
DC input current	Typ.	2.35A	At 110Vdc, at 24V, 10A
Allowed Voltage L/N to Earth	Max.	375Vdc	Continuous, IEC 62477-1
Turn-on voltage	Typ.	80Vdc	Steady state value
Shut-down voltage	Typ.	70Vdc	Steady state value
	Typ.	55Vdc	Dynamic value (max. 250ms)

Fig. 4-1 Wiring for DC Input

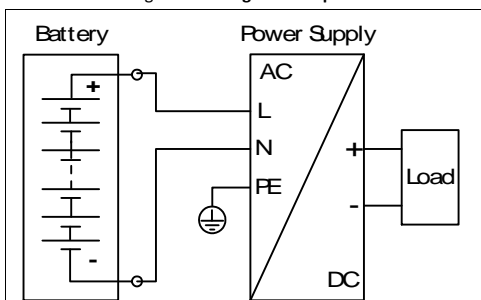

Instructions for DC use:

- Use a battery or a similar DC source. A supply from the intermediate DC-bus of a frequency converter is not recommended and can cause a malfunction or damage the unit.
- Connect +pole to L and -pole to N.
- Connect the PE terminal to an earth wire or to the machine ground.

5. INPUT INRUSH CURRENT

An active inrush limitation circuit (NTCs, which are bypassed by a relay contact) limits the input inrush current after turn-on of the input voltage.

The charging current into EMI suppression capacitors is disregarded in the first microseconds after switch-on.

		AC 100V	AC 120V	AC 230V	
Inrush current	Max.	11A _{peak}	7A _{peak}	11A _{peak}	At 40°C, cold start
	Typ.	9A _{peak}	6A _{peak}	6A _{peak}	At 25°C, cold start
	Typ.	9A _{peak}	6A _{peak}	9A _{peak}	At 40°C, cold start
Inrush energy	Max.	0.1A ² s	0.1A ² s	0.4A ² s	At 40°C, cold start

Fig. 5-1 Typical turn-on behaviour at nominal load, 120Vac input and 25°C ambient

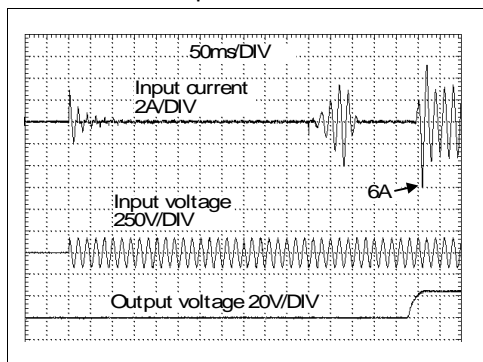
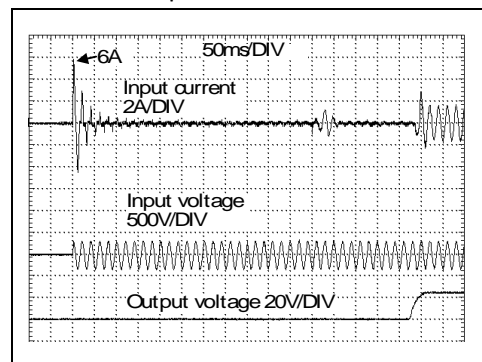

Fig. 5-2 Typical turn-on behavior at nominal load, 230Vac input and 25°C ambient



6. OUTPUT

Output voltage	Nom.	24V	
Adjustment range		24-28V	Guaranteed
	Max.	30.0V****)	At clockwise end position of potentiometer
Factory settings	Typ.	24.1V	±0.2%, at full load and cold unit
Line regulation	Max.	10mV	85-300Vac
Load regulation	Max.	50mV	Static value, 0A → 10A; see Fig. 6-1
Ripple and noise voltage	Max.	50mVpp	20Hz to 20MHz, 50Ohm
Output current	Nom.	10A	At 24V and up to +60°C ambient temperature, see Fig. 6-1
	Nom.	7.5A	At 24V and +70°C ambient temperature, see Fig. 16-1
	Nom.	8.6A	At 28V and up to +60°C ambient temperature, see Fig. 6-1
	Nom.	6.45A	At 28V and +70°C ambient temperature, see Fig. 16-1
	Derate linearly between +60°C and +70°C, see chapter 16		
PowerBoost*)	Nom.	12A	At 24V and up to +45°C ambient temperature, see Fig. 16-1
	Nom.	10.3A	At 28V and up to +45°C ambient temperature, see Fig. 16-1
PowerBoost decreases linearly to nominal power between +45°C and +60°C, see chapter 16.			
Fuse breaking current	Typ.	30A	Up to at least 12ms****), output voltage stays above 20V, see Fig. 6-2 and Fig. 24-3, This peak current is available once every five seconds (hardware controlled).
Output power	Nom.	240W	Continuously available
	Nom.	288W*)	PowerBoost *)
Overload behaviour		cont. current	Output voltage > 13Vdc, see Fig. 6-1
		Hiccup ^{PLUS} mode**)	Output voltage < 13Vdc, see Fig. 6-1
Short-circuit current	Min.	12.5A****)	Load impedance 45mOhm, see Fig. 6-3
	Max.	15.5A****)	Load impedance 45mOhm, see Fig. 6-3
	Max.	5A	Average (R.M.S.) current, load impedance 50mOhm, see Fig. 6-3
	Min.	28A	Up to 12ms, load impedance 45mOhm, see Fig. 6-2
	Typ.	30.5A	Up to 12ms, load impedance 45mOhm, see Fig. 6-2
Output capacitance	Typ.	4 400µF	Included inside the power supply

*) **PowerBoost**

This power/ current is continuously allowed up to an ambient temperature of +45°C.

Above +45°C, do not use this power/ current longer than a duty cycle of 10% and/ or not longer than 1 minute every 10 minutes.

***) **Hiccup^{PLUS} Mode**

At heavy overloads (when output voltage falls below 13V), the power supply delivers continuous output current for 2s. After this, the output is switched off for approx. 18s before a new start attempt is automatically performed. This cycle is repeated as long as the overload exists. If the overload has been cleared, the device will operate normally. See Fig. 6-3

****) Discharge current of output capacitors is not included.

*****) This is the maximum output voltage which can occur at the clockwise end position of the potentiometer due to tolerances. It is not a guaranteed value which can be achieved. The typical value is about 28.5V.

*****) Reduced pulse length for AC 100V mains.

Fig. 6-1 Output voltage vs. output current, typ.

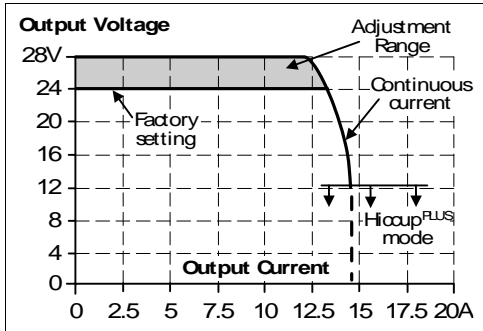

Fig. 6-2 Dynamic output current capability, typ.

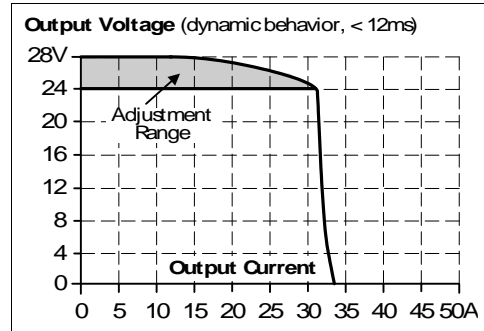
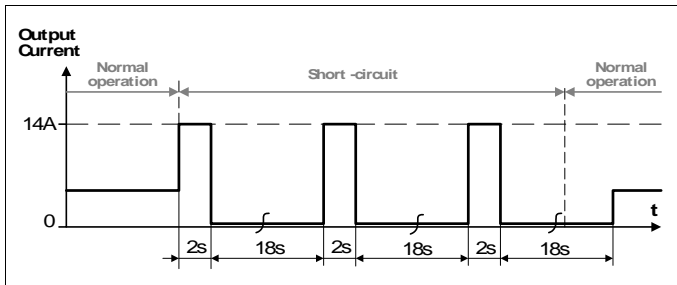

Fig. 6-3 Short-circuit on output, Hiccup^{PLUS} mode, typ.



7. HOLD-UP TIME

		AC 100V	AC 120V	AC 230V	
Hold-up Time	Typ.	73ms	73ms	73ms	At 24V, 5A, see Fig. 7-1
	Min.	55ms	55ms	55ms	At 24V, 5A, see Fig. 7-1
	Typ.	37ms	37ms	37ms	At 24V, 10A, see Fig. 7-1
	Min.	28ms	28ms	28ms	At 24V, 10A, see Fig. 7-1

Fig. 7-1 Hold-up time vs. input voltage

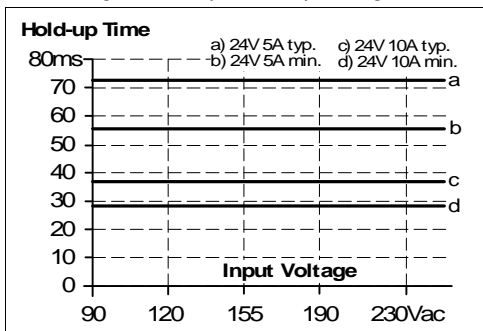
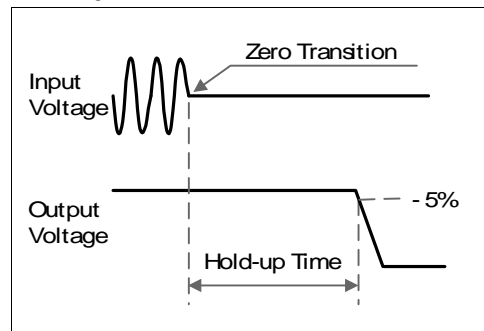

Fig. 7-2 Shut-down behaviour, definitions



8. DC-OK RELAY CONTACT

This feature monitors the output voltage on the output terminals of a running power supply.

Contact closes	As soon as the output voltage reaches typ. 90% of the adjusted output voltage level.		
Contact opens	As soon as the output voltage dips more than 10% below the adjusted output voltage. Short dips will be extended to a signal length of 100ms. Dips shorter than 1ms will be ignored.		
Contact ratings	Max.	60Vdc 0.3A, 30Vdc 1A, 30Vac 0.5A	resistive load
	Min.	1mA at 5Vdc	min. permissible load
Isolation voltage	See dielectric strength table in chapter 18.		

Fig. 8-1 DC-OK relay contact behavior

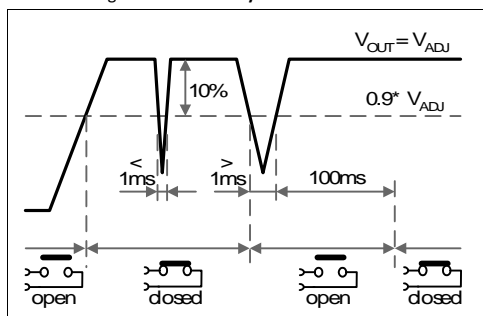

9. EFFICIENCY AND POWER LOSSES

		AC 100V	AC 120V	AC 230V	
Efficiency	Typ.	92.9%	93.6%	95.2%	At 24V, 10A
	Typ.	92.5%	93.4%	95.1%	At 24V, 12A (PowerBoost)
Average efficiency*)	Typ.	92.5%	93.0%	94.3%	25% at 2.5A, 25% at 5A, 25% at 7.5A. 25% at 10A
Power losses	Typ.	2.5W	2.1W	1.8W	At 24V, 0A
	Typ.	9.8W	8.9W	7.1W	At 24V, 5A
	Typ.	18.3W	16.4W	12.1W	At 24V, 10A
	Typ.	23.4W	21.7W	14.8W	At 24V, 12A (PowerBoost)

*) The average efficiency is an assumption for a typical application where the power supply is loaded with 25% of the nominal load for 25% of the time, 50% of the nominal load for another 25% of the time, 75% of the nominal load for another 25% of the time and with 100% of the nominal load for the rest of the time.

Fig. 9-1 Efficiency vs. output current at 24V, typ.

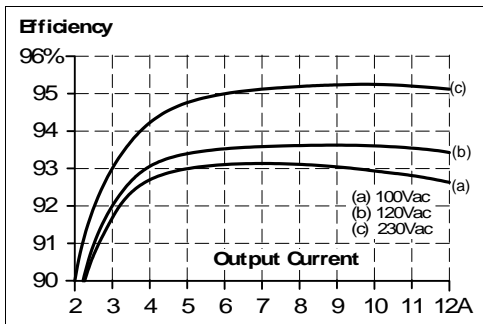

Fig. 9-2 Losses vs. output current at 24V, typ.

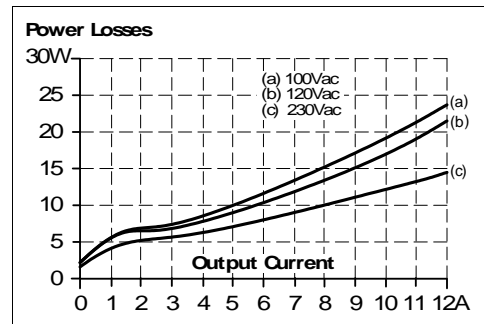

Fig. 9-3 Efficiency vs. input voltage at 24V, 10A, typ.

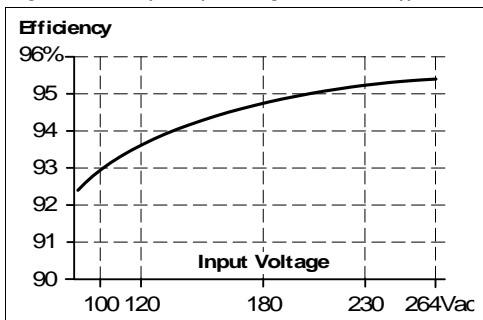
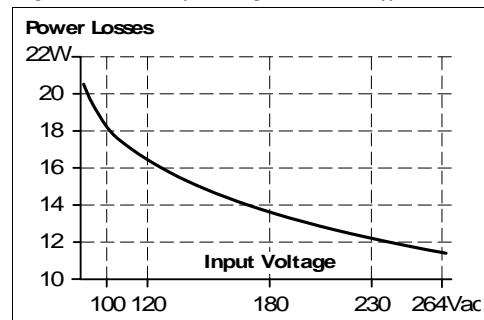

Fig. 9-4 Losses vs. input voltage at 24V, 10A, typ.



10. LIFETIME EXPECTANCY AND MTBF

	AC 100V	AC 120V	AC 230V	
Lifetime expectancy*)	128 000h	141 000h*)	176 000h*)	At 24V, 5A and 40°C
	61 000h	75 000h	120 000h	At 24V, 10A and 40°C
	47 000h	59 000h	101 000h	At 24V, 12A and 40°C
	363 000h*)	399 000h*)	499 000h*)	At 24V, 5A and 25°C
	173 000h*)	211 000h*)	338 000h*)	At 24V, 10A and 25°C
	132 000h*)	166 000h*)	286 000h*)	At 24V, 12A and 25°C
MTBF**) SN 29500, IEC 61709	550 000h	560 000h	661 000h	At 24V, 10A and 40°C
	1 003 000h	1 017 000h	1 176 000h	At 24V, 10A and 25°C
MTBF**) MIL HDBK 217F	188 000h	188 000h	213 000h	At 24V, 10A and 40°C; Ground Benign GB40
	252 000h	252 000h	290 000h	At 24V, 10A and 25°C; Ground Benign GB25
	40 000h	40 000h	47 000h	At 24V, 10A and 40°C; Ground Fixed GF40
	51 000h	51 000h	61 000h	At 24V, 10A and 25°C; Ground Fixed GF25

*) The **Lifetime expectancy** shown in the table indicates the minimum operating hours (service life) and is determined by the lifetime expectancy of the built-in electrolytic capacitors. Lifetime expectancy is specified in operational hours and is calculated according to the capacitor's manufacturer specification. The manufacturer of the electrolytic capacitors only guarantees a maximum life of up to 15 years (131 400h). Any number exceeding this value is a calculated theoretical lifetime which can be used to compare devices.

) **MTBF stands for **Mean Time Between Failure**, which is calculated according to statistical device failures, and indicates reliability of a device. It is the statistical representation of the likelihood of a unit to fail and does not necessarily represent the life of a product.

The MTBF figure is a statistical representation of the likelihood of a device to fail. A MTBF figure of e.g. 1 000 000h means that statistically one unit will fail every 100 hours if 10 000 units are installed in the field. However, it cannot be determined if the failed unit has been running for 50 000h or only for 100h.

11. FUNCTIONAL DIAGRAM

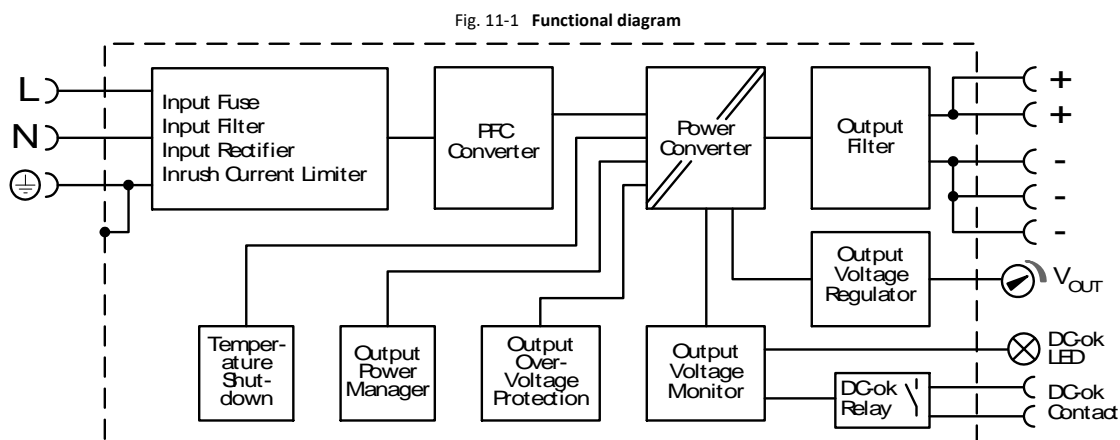

12. TERMINALS AND WIRING

The terminals are IP20 finger safe constructed and suitable for field- and factory wiring.

	Input and Output	DC-OK-Signal
Type	Quick-connect spring-clamp terminals	Push-in terminals
Solid wire	Max. 6mm ²	Max. 1.5mm ²
Stranded wire	Max. 4mm ²	Max. 1.5mm ²
American Wire Gauge	Max. AWG 20-10	Max. AWG 28-16
Wire diameter (including ferrules)	Max. 2.8mm	Max. 1.6mm
Wire stripping length	10mm	7mm
Screwdriver	Not applicable	Not required
Recommended tightening torque	Not applicable	Not applicable

Instructions:

- Use appropriate copper cables that are designed for minimum operating temperatures of:
90°C for ambient between 45°C and 60°C minimum
105°C for ambient up to 70°C minimum.
- Follow national installation codes and installation regulations!
- Ensure that all strands of a stranded wire enter the terminal connection!
- Do not use the unit without PE connection.
- Unused terminal compartments should be securely tightened.
- Ferrules are allowed.

Daisy chaining:

Daisy chaining (jumping from one power supply output to the next) is allowed as long as the average output current through one terminal pin does not exceed 25A. If the current is higher, use a separate distribution terminal block as shown in Fig. 12-2.

Fig. 12-1 Daisy chaining of outputs

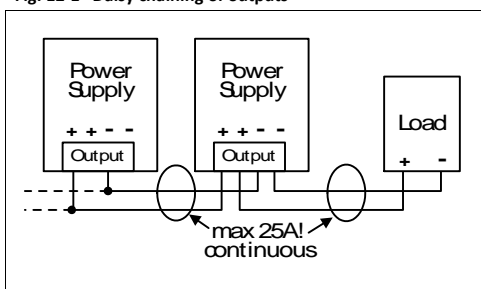
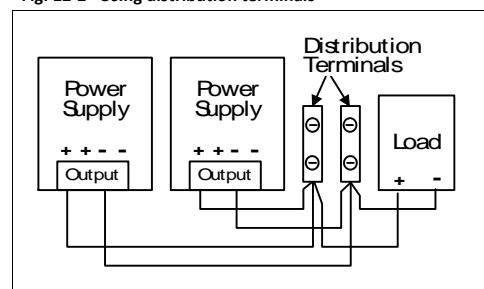

Fig. 12-2 Using distribution terminals



13. FRONT SIDE AND USER ELEMENTS

Fig. 13-1



A Input Terminals

Quick-connect spring-clamp terminals

N, L Line input

\oplus PE (Protective Earth) input

B Output Terminals

(two identical + poles and three identical - poles)

Quick-connect spring-clamp terminals

+ Positive output

- Negative (return) output

C Output voltage potentiometer

Open the flap to adjust the output voltage. Factory set: 24.1V

D DC-OK LED (green)

On, when the output voltage is >90% of the adjusted output voltage

E DC-OK Relay Contact

(Push-in terminals)

Monitors the output voltage of the running power supply.

See chapter 8 for details.

14. EMC – ACCORDING TO MEDICAL STANDARDS

EMC Immunity		According to medical standard: EN 60601-1-2		
Electrostatic discharge	EN 61000-4-2	Contact discharge	8kV	Criterion A
		Air discharge	15kV	Criterion A
		Air discharge DC OK signal	8kV	Criterion A
Electromagnetic RF field	EN 61000-4-3	80MHz-2.7GHz	10V/m	Criterion A
	EN 61000-4-3, EN 60601-1-2 table 9	385MHz-5.78GHz	9-28V/m	Criterion A
Fast transients (Burst)	EN 61000-4-4	Input lines	2kV	Criterion A
		Output lines	1kV	Criterion A
		DC-OK signal (coupling clamp)	1kV	Criterion A
Surge voltage on input	EN 61000-4-5	L → N	1kV	Criterion A
		L → PE, N → PE	2kV	Criterion A
Conducted disturbance	EN 61000-4-6	0.15-80MHz	6V	Criterion A
Rated power frequency magnetic fields	EN 61000-4-8	Frequency 50Hz	30A/m	Criterion A
		Frequency 60Hz	30A/m	Criterion A
Mains voltage dips	EN 61000-4-11	0% of 100Vac	0Vac, 10ms	Criterion A
		0% of 100Vac	0Vac, 20ms	Criterion A
		70% of 100Vac	70Vac, 500ms	Criterion A
		0% of 240Vac	0Vac, 10ms	Criterion A
		0% of 240Vac	0Vac, 20ms	Criterion A
		70% of 240Vac	168Vac, 500ms	Criterion A
Voltage interruptions	EN 61000-4-11	0% of 100Vac	0Vac, 5000ms	Criterion B
		0% of 240Vac	0Vac, 5000ms	Criterion B

Criteria:

- A:** Power supply shows normal operation behavior within the defined limits.
- B:** Output voltage out of range or switches off. DC-OK signal might trigger. Restores automatically after the test.

EMC Emission		According to generic standard: EN 60601-1-2	
Conducted emission input lines	EN 55011, CISPR 11	Class B for AC Input voltages and Class A for DC input voltages	
Radiated emission	EN 55011, CISPR 11	Class B	
Harmonic input current	EN 61000-3-2	Class A fulfilled between 0A and 12A load	
		Class C fulfilled between 6A and 12A load	
Voltage fluctuations, flicker	EN 61000-3-3	Fulfilled*)	

Switching Frequencies		The power supply has three converters with two different switching frequencies included.	
Switching frequency 1	110kHz	PFC converter	
Switching frequency 2	84kHz to 140kHz	Main converter, output power dependent	
Switching frequency 3	60kHz	Auxiliary converter	

15. EMC – ACCORDING TO GENERIC STANDARDS

In regard to EMC, the power supply is designed for applications in medical applications, industrial environment as well as in residential, commercial and light industry environment.

EMC Immunity	According to generic standards: EN 61000-6-1 and EN 61000-6-2			
Electrostatic discharge	EN 61000-4-2	Contact discharge	8kV	Criterion A
		Air discharge	15kV	Criterion A
Electromagnetic RF field	EN 61000-4-3	80MHz-2.7GHz	20V/m	Criterion A
Fast transients (Burst)	EN 61000-4-4	Input lines	4kV	Criterion A
		Output lines	2kV	Criterion A
		DC-OK signal (coupling clamp)	2kV	Criterion A
Surge voltage on input	EN 61000-4-5	L → N	2kV	Criterion A
		L → PE, N → PE	4kV	Criterion A
Surge voltage on output	EN 61000-4-5	+ → -	1kV	Criterion A
		+ / - → PE	2kV	Criterion A
Surge voltage on Signals	EN 61000-4-5	DC-OK signal → PE	1kV	Criterion A
Conducted disturbance	EN 61000-4-6	0.15-80MHz	20V	Criterion A
Mains voltage dips	EN 61000-4-11	0% of 100Vac	0Vac, 20ms	Criterion A
		40% of 100Vac	40Vac, 200ms	Criterion C
		70% of 100Vac	70Vac, 500ms	Criterion A
		0% of 200Vac	0Vac, 20ms	Criterion A
		40% of 200Vac	80Vac, 200ms	Criterion A
		70% of 200Vac	140Vac, 500ms	Criterion A
Voltage interruptions	EN 61000-4-11	0% of 200Vac	0Vac, 5000ms	Criterion C
Voltage sags	SEMI F47	dips on the input voltage according to SEMI F47 standard		
		80% of 120Vac (96Vac)	1000ms	Criterion A
		70% of 120Vac (84Vac)	500ms	Criterion A
		50% of 120Vac (60Vac)	200ms	Criterion A
Powerful transients	VDE 0160	Over entire load range	750V, 0.3ms	Criterion A

Criteria:

- A:** Power supply shows normal operation behavior within the defined limits.
- C:** Temporary loss of function is possible. Power supply may shut-down and restarts by itself. No damage or hazards for the power supply will occur.

EMC Emission	According to generic standards: EN 61000-6-3 and EN 61000-6-4	
Conducted emission input lines	EN 55011, EN 55015, EN 55032, FCC Part 15, CISPR 11, CISPR 32	Class B for AC Input voltages and Class A for DC input voltages
Conducted emission output lines**)	IEC/CISPR 16-1-2, IEC/CISPR 16-2-1	12dB higher than average limits for DC power port according to EN 61000-6-3**)
Radiated emission	EN 55011, EN 55032	Class B
Harmonic input current	EN 61000-3-2	Class A fulfilled between 0A and 12A load Class C fulfilled between 6A and 12A load
Voltage fluctuations, flicker	EN 61000-3-3	Fulfilled*)

This device complies with FCC Part 15 rules.

Operation is subjected to following two conditions: (1) this device may not cause harmful interference, and (2) this device must accept any interference received, including interference that may cause undesired operation.

*) Tested with constant current loads, non pulsing

**) For information only, not mandatory for EN 61000-6-3 or EN 61000-6-4

Restrictions apply only for applications in residential, commercial and light-industrial environments, where local DC power networks according to EN 61000-6-3 are involved. No restrictions for all kinds of industrial applications.

16. ENVIRONMENT

Operational temperature ^{*)}	-25°C to +70°C	Reduce output power according Fig. 16-1
Non-operational temperature	-40°C to +85°C	For storage and transportation
Output derating	6W/K	Between +60°C and +70°C
Humidity ^{**)}	5 to 95% r.h.	For operation, storage and transportation according to IEC 60068-2-30
Atmospheric pressure	106-70kPa	For operation, storage and transportation
Vibration sinusoidal	2-17.8Hz: ±1.6mm; 17.8-500Hz: 2g ^{***)} 2 hours / axis ^{***)}	IEC 60068-2-6
Shock	30g 6ms, 20g 11ms ^{***)} 3 bumps / direction, 18 bumps in total	IEC 60068-2-27
Altitude	0 to 3000m	For medical applications
	0 to 2000m	For all other applications
	2000 to 6000m	Reduce output power or ambient temperature, see Fig. 16-2.
Altitude derating	15W/1000m or 5K/1000m	For altitudes >2000m, see Fig. 16-2
Over-voltage category	III	Altitudes up to 2000m according to IEC/EN 62477-1,
	II	For altitudes from 2000m to 6000m
Degree of pollution	2	According to IEC/EN 62477-1, not conductive

^{*)} Operational temperature is the same as the ambient or surrounding temperature and is defined as the air temperature 2cm below the unit.

^{**)} Do not energize while condensation is present

^{***)} Tested in combination with DIN rails according to EN 60715 with a height of 15mm and a thickness of 1.3mm and standard orientation.

Fig. 16-1 Output current vs. ambient temp.
(Inom 10A; Iout with PowerBoost = 12A)

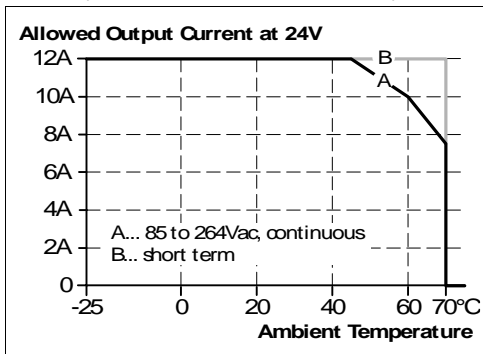
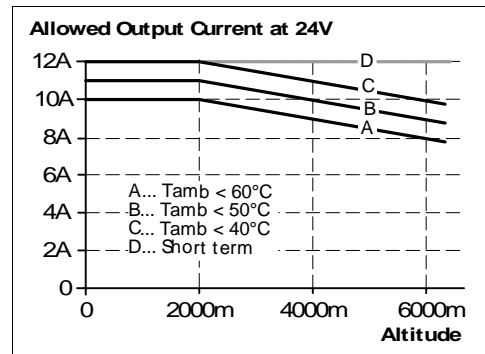

Fig. 16-2 Output current vs. altitude



17. SAFETY FEATURES

Input / output separation ¹⁾	SELV PELV double or reinforced insulation	IEC/EN 60950-1 IEC/EN 60204-1, IEC/EN 62477-1, IEC 60364-4-41
Transformers	Safety Isolating Transformers acc. IEC/EN 61558-2-16	Safety Isolating Transformers corresponding to Part 2-6 of the IEC/EN 61558
Class of protection	I	PE (Protective Earth) connection required
Isolation resistance	Min. 500MΩ	Input to output, measured with 500Vdc
PE resistance	Max. 0.1Ω	PE terminal to enclosure
Earth leakage current, industrial	Typ. 0.06mA / 0.17mA Typ. 0.09mA / 0.24mA Typ. 0.15mA / 0.42mA Max. 0.08mA / 0.20mA Max. 0.11mA / 0.30mA Max. 0.20mA / 0.55mA	100Vac, 50Hz, TN-,TT-mains / IT-mains 120Vac, 60Hz, TN-,TT-mains / IT-mains 230Vac, 50Hz, TN-,TT-mains / IT-mains 110Vac, 50Hz, TN-,TT-mains / IT-mains 132Vac, 60Hz, TN-,TT-mains / IT-mains 264Vac, 50Hz, TN-,TT-mains / IT-mains
Earth leakage current ^{2) 3)} , medical	Typ. 0.21mA Max. 0.24mA Typ. 0.41mA Max. 0.47mA	264Vac, 60Hz, normal condition 264Vac, 60Hz, normal condition 264Vac, 60Hz, single fault condition 264Vac, 60Hz, single fault condition
Touch current ^{2) 3)} , medical, Mains to enclosure	Typ. 0.001mA Max. 0.001mA Typ. 0.21mA Max. 0.24mA	264Vac, 60Hz, normal condition 264Vac, 60Hz, normal condition 264Vac, 60Hz, single fault condition 264Vac, 60Hz, single fault condition
Touch current ^{2) 3)} , medical, Mains to output GND (-) pole	Typ. 0.009mA Max. 0.015mA Typ. 0.13mA Max. 0.15mA	264Vac, 60Hz, normal condition 264Vac, 60Hz, normal condition 264Vac, 60Hz, single fault condition 264Vac, 60Hz, single fault condition
Touch current ^{2) 3)} , medical, Mains to output plus (+) pole	Typ. 0.008mA Max. 0.013mA Typ. 0.14mA Max. 0.16mA	264Vac, 60Hz, normal condition 264Vac, 60Hz, normal condition 264Vac, 60Hz, single fault condition 264Vac, 60Hz, single fault condition

- 1) Double or reinforced insulation
- 2) After humidity preconditioning treatment
- 3) No classification according class B, BF and CF since the power supply is not suitable for application parts with direct patient contact.

18. PROTECTION FEATURES

Output protection	Electronically protected against overload, no-load and short-circuits ^{*)}	
Output over-voltage protection	Typ. 30.5Vdc Max. 32Vdc	In case of an internal power supply defect, a redundant circuit limits the maximum output voltage. The output shuts down and automatically attempts to restart.
Degree of protection	IP 20	EN/IEC 60529 For use in a controlled environment according to CSA 22.2 No 107.1-01.
Penetration protection	> 4mm	e.g. screws, small parts
Over-temperature protection	yes	Output shut-down with automatic restart
Input transient protection	MOV (Metal Oxide Varistor)	
Internal input fuse	Included (1 fuse in L-line)	not user replaceable

^{*)} In case of a protection event, audible noise may occur.

19. DIELECTRIC STRENGTH

The output voltage is floating and has no ohmic connection to the ground. Type and factory tests are conducted by the manufacturer. Field tests may be conducted in the field using the appropriate test equipment which applies the voltage with a slow ramp (2s up and 2s down). Connect all input-terminals together as well as all output poles before conducting the test. When testing, set the cut-off current settings to the value in the table below.

Fig. 19-1 Dielectric strength

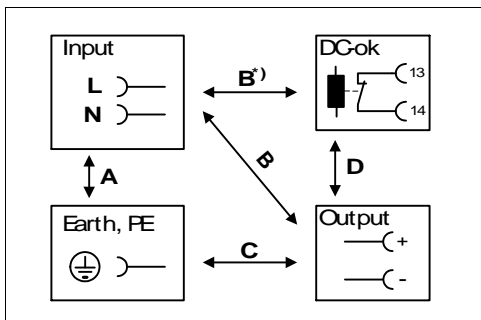

B*) When testing input to DC-OK ensure that the max. voltage between DC-OK and the output is not exceeded (column D). We recommend connecting DC-OK pins and the output pins together when performing the test.

		A	B	C	D
Type test	60s	3000Vac	4500Vac	1500Vac	500Vac
Factory test	5s	3000Vac	4000Vac	1000Vac	500Vac
Field test	5s	2700Vac	3500Vac	800Vac	500Vac
Cut-off current setting		> 10mA	> 5mA	> 5mA	> 1mA



Insulation Safety Ratings

Input to Ground	MOPP, MOOP
Input to Output	2MOPP, 2MOOP
Output to Ground	MOPP, MOOP

20. APPROVED, FULFILLED OR TESTED STANDARDS

IEC 60601 2MOPP	CB Report	CB-Scheme Certificate IEC 60601-1 - Medical electrical equipment - General requirements for basic safety and essential performance 2MOPP
EN 60601-1-2	EMC Medical	Agency Certificate (SIQ) EN 60601-1-2 - Medical electrical equipment - Requirements for electromagnetic disturbances (EMC)
UL 60601 2MOPP		UL Certificate Recognized component for category QQHM - UL 60601-1 Medical Electrical Equipment - General Requirements for Safety Applicable for US and Canada E207953 2MOPP
VDMA 24364	LABS VDMA 24364-C1-L/W	Paint Wetting Impairment Substances Test (or LABS-Test) Tested for Zone 2 and test class C1 according to VDMA 24364-C1-L/W for solvents and water-based paints

21. REGULATORY PRODUCT COMPLIANCE

EU Declaration of Conformity		The CE mark indicates conformance with the - EMC directive - Low-voltage directive - RoHS directive
REACH Regulation (EU)	REACH ✓	Manufacturer's Declaration EU regulation regarding the Registration, Evaluation, Authorisation and Restriction of Chemicals (REACH) fulfilled. EU Regulation (EC) 1907/2006.
WEEE Regulation		Manufacturer's Declaration EU Regulation on Waste Electrical and Electronic Equipment Registered as business to business (B2B) products. EU Regulation 2012/19/EU

22. PHYSICAL DIMENSIONS AND WEIGHT

Width	39mm
Height	124mm
Depth	117mm
	The DIN rail depth must be added to the unit depth to calculate the total required installation depth.
Weight	620g
DIN rail	Use 35mm DIN rails according to EN 60715 or EN 50022 with a height of 7.5 or 15mm.
Housing material	Body: Aluminium alloy Cover: Zinc-plated steel
Installation clearances	See chapter 2

Fig. 22-1 Front view

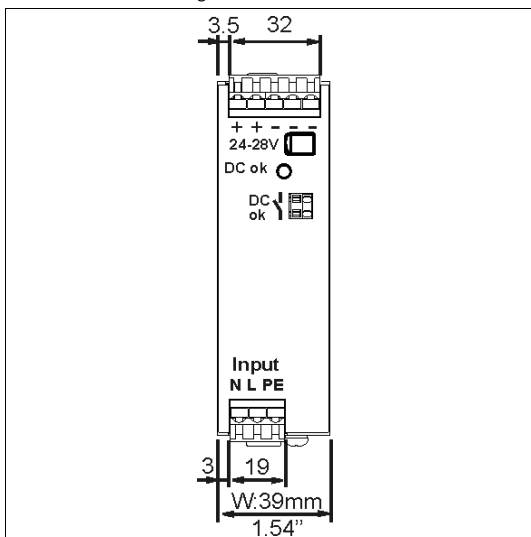
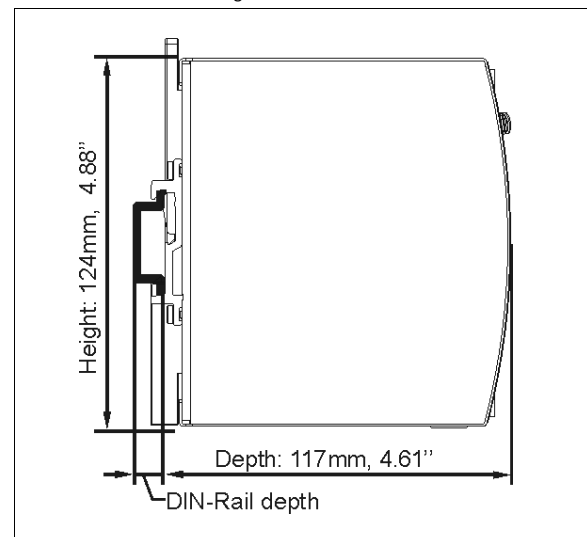

Fig. 22-2 Side view



23. ACCESSORIES

23.1. ZM10.WALL - WALL/PANEL MOUNT BRACKET

This bracket is used to mount the devices on a wall/panel without utilizing the DIN rail. The bracket can be mounted without detaching the DIN rail brackets from the power supply. PSU for illustration purpose only.

Fig. 23-1 Isometric view

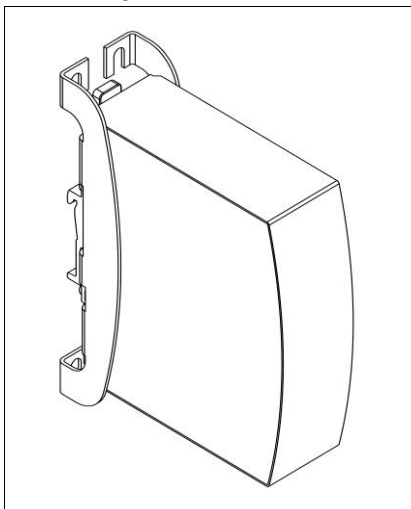

Fig. 23-2 Isometric view

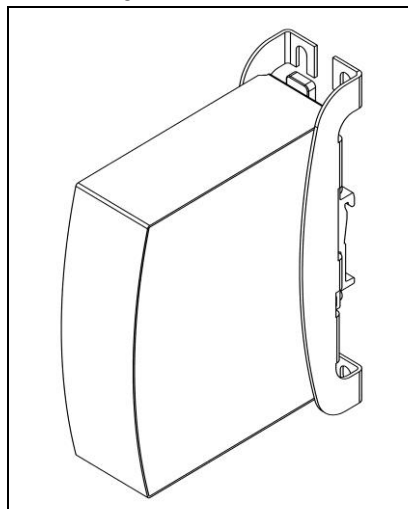

Fig. 23-3 Isometric view

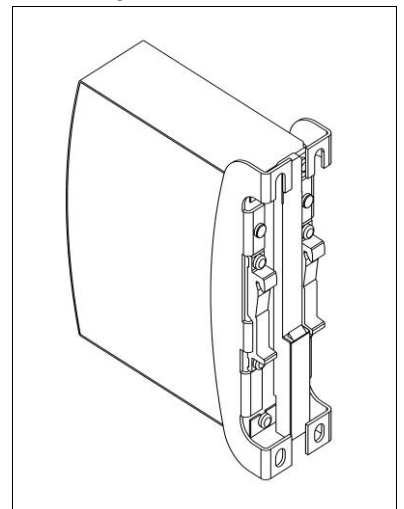

Fig. 23-4 Wall/panel mounting, front view

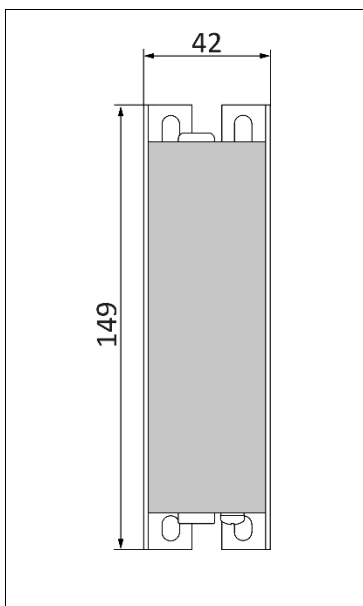

Fig. 23-5 Hole pattern for wall mounting

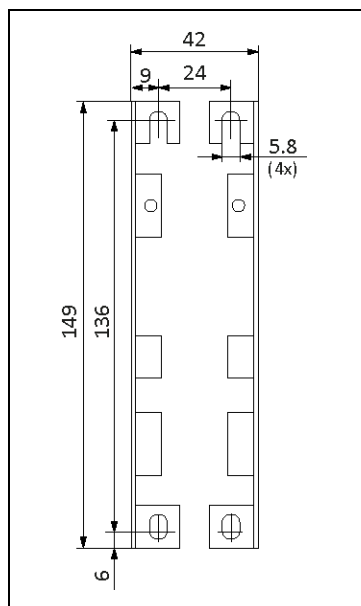
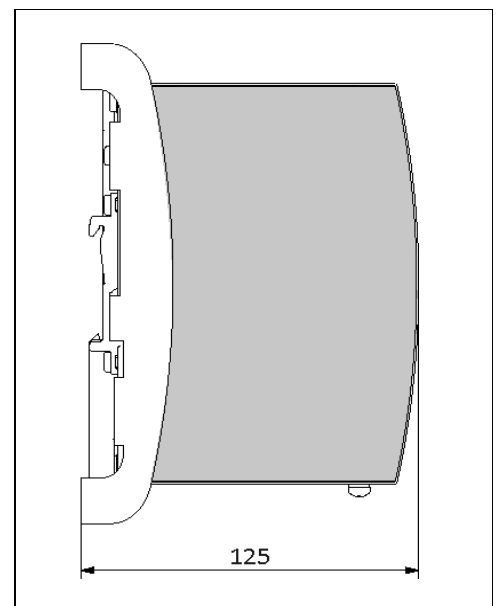

Fig. 23-6 Wall/panel mounting, side view



23.2. ZM12.SIDE - SIDE MOUNTING BRACKET

This bracket is used to mount the device sideways with or without utilizing a DIN rail.

The two aluminum brackets and the black plastic slider of the unit have to be detached, so that the steel brackets can be mounted.

For sideways DIN rail mounting, the removed aluminum brackets and the black plastic slider need to be mounted on the steel bracket.

Fig. Fehler! Verweisquelle konnte nicht gefunden werden.-5 ZM12.SIDE Side mounting bracket*)

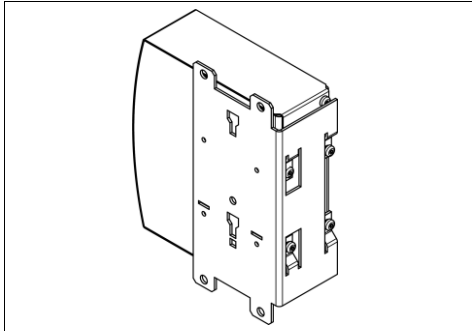
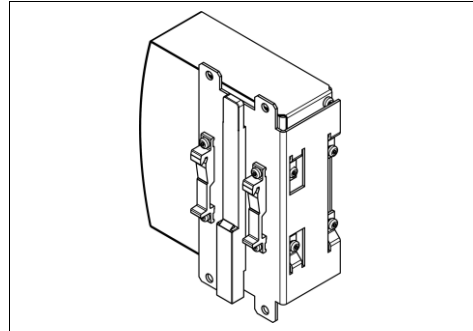

Fig. Fehler! Verweisquelle konnte nicht gefunden werden.-6 Side mounting with DIN rail brackets*)



*) PSU for illustration purpose only.

24. APPLICATION NOTES

24.1. PEAK CURRENT CAPABILITY

The unit can deliver peak currents (up to several milliseconds) which are higher than the specified short term currents.

This helps to start current demanding loads. Solenoids, contactors and pneumatic modules often have a steady state coil and a pick-up coil. The inrush current demand of the pick-up coil is several times higher than the steady-state current and usually exceeds the nominal output current (including the PowerBoost). The same situation applies when starting a capacitive load.

The peak current capability also ensures the safe operation of subsequent circuit breakers of load circuits. The load branches are often individually protected with circuit breakers or fuses. In case of a short or an overload in one branch circuit, the fuse or circuit breaker need a certain amount of over-current to open in a timely manner. This avoids voltage loss in adjacent circuits.

The extra current (peak current) is supplied by the power converter and the built-in large sized output capacitors of the power supply. The capacitors get discharged during such an event, which causes a voltage dip on the output. The following two examples show typical voltage dips:

Fig. 24-1 Peak load with 2x the nominal current for 50ms, typ.

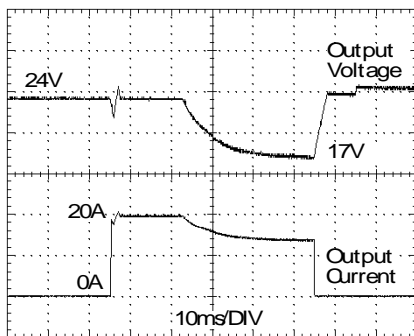

20A Peak load (resistive) for 50ms
Output voltage dips from 24V to 17V.

Fig. 24-2 Peak load with 5x the nominal current for 5ms, typ.

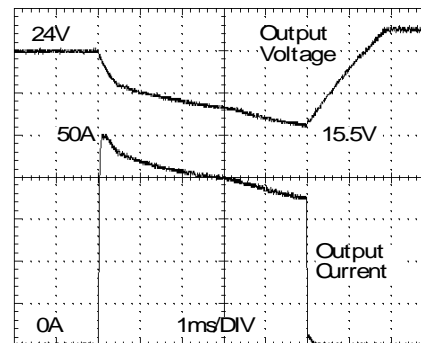

50A Peak load (resistive) for 5ms
Output voltage dips from 24V to 15.5V.

Fig. 24-3 30A Peak load, typ.

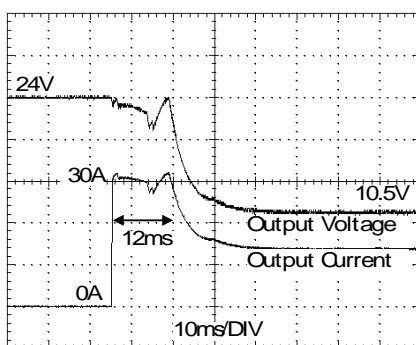

High Overload Current (typ. 30A for 12ms)
enables easy fuse tripping

Please note: The DC-OK relay triggers when the voltage dips more than 10% for longer than 1ms.

Peak current voltage dips	Typ.	From 24V to 17V	At 20A for 50ms, resistive load
	Typ.	From 24V to 19V	At 50A for 2ms, resistive load
	Typ.	From 24V to 15.5V	At 50A for 5ms, resistive load

24.2. BACK-FEEDING LOADS

Loads such as decelerating motors and inductors can feed voltage back to the power supply. This feature is also called return voltage immunity or resistance against Back- E.M.F. (Electro Magnetic Force).

This power supply is resistant and does not show malfunctioning when a load feeds back voltage to the power supply. It does not matter whether the power supply is on or off.

The maximum allowed feed-back-voltage is 35Vdc. The maximum allowed feed-back peak current is 40A. Higher currents can temporarily shut-down the output voltage. The absorbing energy can be calculated according to the built-in large sized output capacitor which is specified in chapter 6.

24.3. EXTERNAL INPUT PROTECTION

The unit is tested and approved for branch circuits up to 30A (UL) and 32A (IEC). An external protection is only required if the supplying branch has an ampacity greater than this. Check also local codes and local requirements. In some countries local regulations might apply.

If an external fuse is necessary or utilized, minimum requirements need to be considered to avoid nuisance tripping of the circuit breaker. A minimum value of 6A B- or C-Characteristic breaker should be used.

24.4. OUTPUT CIRCUIT BREAKERS

Standard miniature circuit breakers (MCB's or UL 1077 circuit breakers) are commonly used for AC-supply systems and may also be used on 24V branches.

MCB's are designed to protect wires and circuits. If the ampere value and the characteristics of the MCB are adapted to the wire size that is used, the wiring is considered as thermally safe regardless of whether the MCB opens or not.

To avoid voltage dips and under-voltage situations in adjacent 24V branches which are supplied by the same source, a fast (magnetic) tripping of the MCB is desired. A quick shutdown within 10ms is necessary corresponding roughly to the ride-through time of PLC's. This requires power supplies with high current reserves and large output capacitors. Furthermore, the impedance of the faulty branch must be sufficiently small in order for the current to actually flow. The best current reserve in the power supply does not help if Ohm's law does not permit current flow. The following table has typical test results showing which B- and C-Characteristic MCBs magnetically trip depending on the wire cross Chapter and wire length.

Fig. 24-4 Test circuit

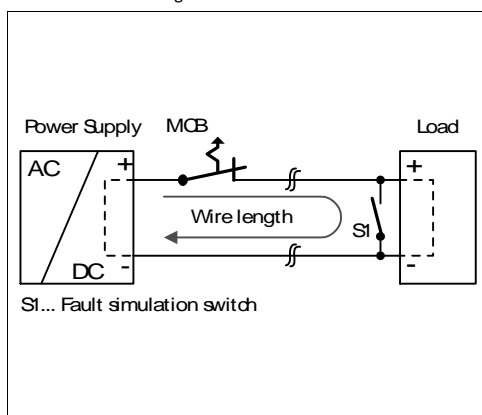

Maximal wire length^{*)} for a fast (magnetic) tripping:

	0.75mm ²	1.0mm ²	1.5mm ²	2.5mm ²
C-2A	30m	37m	54m	84m
C-3A	25m	30m	46m	69m
C-4A	9m	15m	25m	34m
C-6A	3m	3m	4m	7m
B-6A	12m	15m	21m	34m
B-10A	3m	3m	4m	9m
B-13A	2m	2m	3m	6m

*) Don't forget to consider twice the distance to the load (or cable length) when calculating the total wire length (+ and - wire).

24.5. SERIES OPERATION

Do not use the power supply in series. The leakage current will be too high to meet the medical requirements.

24.6. PARALLEL USE TO INCREASE OUTPUT POWER

Do not use the power supply in parallel. The leakage current will be too high to meet the medical requirements.

24.7. PARALLEL USE FOR REDUNDANCY

Do not use the power supply in parallel. The leakage current will be too high to meet the medical requirements.

24.8. INDUCTIVE AND CAPACITIVE LOADS

The unit is designed to supply any kind of loads, including capacitive and inductive loads. If extreme large capacitors, such as EDLCs (electric double layer capacitors or "UltraCaps") with a capacitance larger than 1.5F are connected to the output, the unit might charge the capacitor in the Hiccup^{PLUS} mode (see chapter 6).

24.9. CHARGING OF BATTERIES

The power supply can be used to charge lead-acid or maintenance free batteries (SLA or VRLA batteries). Two 12V batteries are needed in series.

Instructions for charging batteries:

- a) Set output voltage (measured at no load and at the battery end of the cable) very precisely to the end-of-charge voltage.

End-of-charge voltage	27.8V	27.5V	27.15V	26.8V
Battery temperature	10°C	20°C	30°C	40°C

- b) Use a 15A or 16A circuit breaker (or blocking diode) between the power supply and the battery.
- c) Ensure that the output current of the power supply is below the allowed charging current of the battery.
- d) Use only matched batteries when putting 12V types in series.
- e) Ensure that the ambient temperature of the power supply stays below 40°C.
- f) The return current to the power supply (battery discharge current is typ. 3.5mA when the power supply is switched off (except in case a blocking diode is utilized).

24.10. OPERATION ON TWO PHASES

The power supply can also be used on two-phases of a three-phase-system. Such a phase-to-phase connection is allowed as long as the supplying voltage is below 240V^{+10%}.

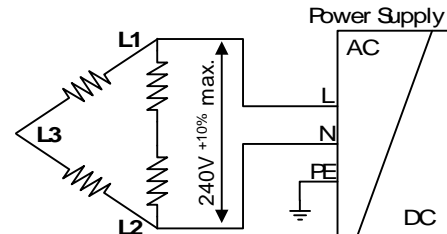

24.11. USE IN A TIGHTLY SEALED ENCLOSURE

When the power supply is installed in a tightly sealed enclosure, the temperature inside the enclosure will be higher than outside. In such situations, the inside temperature defines the ambient temperature for the power supply.

The following measurement results can be used as a reference to estimate the temperature rise inside the enclosure.

The power supply is placed in the middle of the box, no other heat producing items are inside the box

Input: 230Vac

Case A: Enclosure: Rittal Typ IP66 Box PK 9519 100, plastic, 180x180x165mm
 Load: 24V, 8A; (=80%) load is placed outside the box
 Temperature inside the box: 42.0°C (in the middle of the right side of the power supply with a distance of 1cm)
 Temperature outside the box: 25.8°C
 Temperature rise: 16.2K

Case B: Enclosure: Rittal Typ IP66 Box PK 9519 100, plastic, 180x180x165mm
 Load: 24V, 10A; load is placed outside the box
 Temperature inside the box: 48.1°C (in the middle of the right side of the power supply with a distance of 1cm)
 Temperature outside the box: 26.2°C
 Temperature rise: 21.9K

Case C: Enclosure: Rittal Typ IP66 Box PK 9516 100, plastic, 110x180x165mm
 Load: 24V, 8A; (=80%) load is placed outside the box
 Temperature inside the box: 48.6°C (in the middle of the right side of the power supply with a distance of 1cm)
 Temperature outside the box: 26.3°C
 Temperature rise: 22.3K

Case D: Enclosure: Rittal Typ IP66 Box PK 9519 100, plastic, 110x180x165mm
 Load: 24V, 10A; load is placed outside the box
 Temperature inside the box: 53.8°C (in the middle of the right side of the power supply with a distance of 1cm)
 Temperature outside the box: 26.6°C
 Temperature rise: 27.3K

24.12. MOUNTING ORIENTATIONS

Mounting orientations other than all terminals on the bottom require a reduction in continuous output power or a limitation in the maximum allowed ambient temperature. The amount of reduction influences the lifetime expectancy of the power supply. Therefore, two different derating curves for continuous operation can be found below:

Curve A1 Recommended output current.

Curve A2 Max allowed output current (results in approximately half the lifetime expectancy of A1).

Fig. 24-5
Mounting
Orientation A
(Standard
orientation)

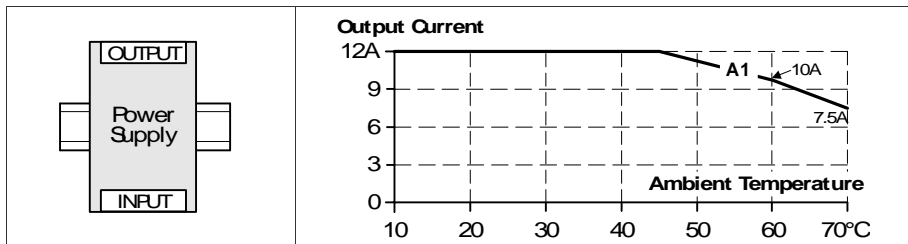

Fig. 24-6
Mounting
Orientation B
(Upside down)

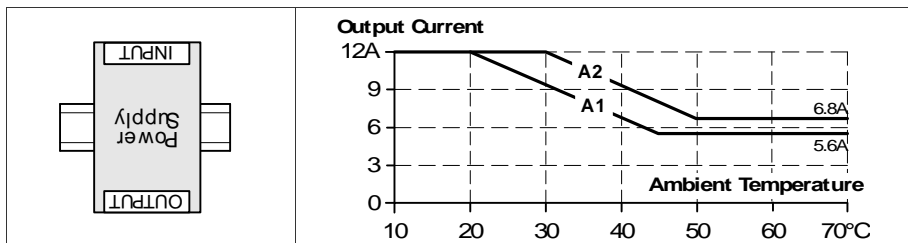

Fig. 24-7
Mounting
Orientation C
(Table-top
mounting)

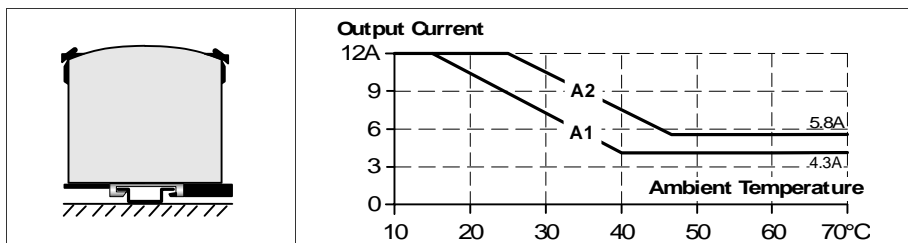

Fig. 24-8
Mounting
Orientation D
(Horizontal cw)

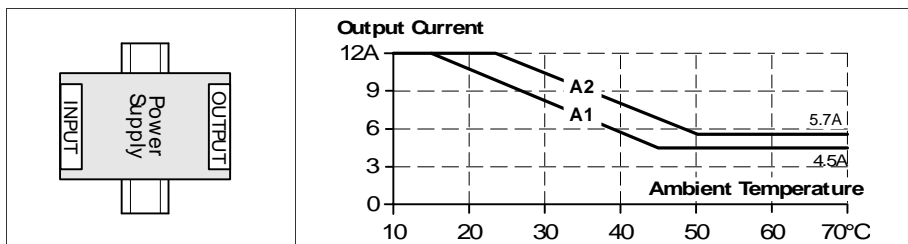

Fig. 24-9
Mounting
Orientation E
(Horizontal ccw)

