



MOSFET REDUNDANCY MODULE

- For N+1 and 1+1 Redundant Systems
- Dual Input with Single Output
- Suitable for all Power Supplies
- Only 72mV Voltage Drop at 20A Output Current
- Only 2.15W Loss at 20A and 6.3W at 40A Output Current
- 160% (65A) Peak Load Capability
- Reverse Input Polarity Protection
- Full Power Between -40°C and +70°C
- Width only 36mm
- Rugged Metal Housing
- Easy Wiring:
Distribution Terminal for Negative Pole Included
- 3 Year Warranty

PRODUCT DESCRIPTION

The YR40.241 is a redundancy module, which can be used to build 1+1 and N+1 redundant system. It is equipped with two input channels, which can be connected to power supplies with up to 20A output current and one output, which can carry nominal currents up to 40A. The module is suitable for power supplies with constant current overload behavior as well as any kind of "Hiccup" overload behavior. In addition to the YR40.241, the YR40.242 is also available which is cost-optimized and suitable for all DIMENSION power supplies except the QT20 and QTD20 series.

The novelty of this redundancy module is the utilization of mosfets instead of diodes for the decoupling of the two input channels. This reduces the heat generation and the voltage drop between input and output. The redundancy module does not require an additional auxiliary voltage and is self-sufficient even in case of a short circuit across the output.

Due to the low power losses, the unit is very slender and only requires 36mm width on the DIN rail. Large connection terminals allow for a safe and fast installation with a large international approval package. This unit is suitable for nearly every application.

ORDER NUMBERS

Redundancy Module	YR40.241	12-28V Standard unit
Accessory	ZM2.WALL	Wall/ panel mount bracket
	ZM11.SIDE	Side mount bracket

SHORT-FORM DATA

Input voltage	DC 12-28V	±30%
Input voltage range	8.4-36.4Vdc	
Input current	2x 0-20A	continuous
	2x 20-32.5A	for 5 seconds
Output current	0-40A	continuous
	40-65A	for 5 seconds
	65A	at cont. overload or short circuit
Input to output voltage drop	typ. 72mV typ. 112mV typ. 140mV	input: 2x10A input: 1x20A input: 2x20A
Power losses	typ. 700mW typ. 2.15W typ. 2.65W typ. 6.3W	at no load input: 2x10A input: 1x20A input: 2x20A
Temperature range	-40°C to +70°C	operational, no derating req.
Dimensions	36x124x127mm*)	WxHxD
Weight	340g / 0.75lb	

*) plus, 4mm in depth for the screw terminal

MAIN APPROVALS

For details and the complete approval list, see chapter 14.



UL 508



UL 60950-1



Class I Div 2



ATEX



IECEX



Marine

INDEX

	Page		Page
1. Intended Use	3	15. Regulatory Product Compliance	14
2. Installation Instructions	3	16. Physical Dimensions and Weight	15
3. Input and Output Characteristics	5	17. Accessories	16
4. Power Losses	6	17.1. ZM2.WALL - Wall-Mounting Bracket.....	16
5. Lifetime Expectancy and MTBF.....	7	17.2. ZM11.SIDE - Side Mounting Bracket.....	16
6. Terminals and Wiring.....	8	18. Application Notes.....	17
7. Functional Diagram.....	9	18.1. Recommendations for Redundancy.....	17
8. Front Side and User Elements.....	9	18.2. Inductive and Capacitive Loads.....	17
9. EMC.....	10	18.3. Sideward Installation Clearances.....	17
10. Environment.....	11	18.4. 1+1 Redundancy up to 20A.....	18
11. Protection Features	12	18.5. N+1 Redundancy, Example with 60A	18
12. Safety Features	12	18.6. Mounting Orientations	19
13. Dielectric Strength	12		
14. Approved, Fulfilled or Tested Standards.....	13		

The information presented in this document is believed to be accurate and reliable and may change without notice. No part of this document may be reproduced or utilized in any form without permission in writing from the publisher.

TERMINOLOGY AND ABBREVIATIONS

PE and \oplus symbol	PE is the abbreviation for Protective Earth and has the same meaning as the symbol \oplus .
Earth, Ground	This document uses the term "earth" which is the same as the U.S. term "ground".
t.b.d.	To be defined, value or description will follow later.
DC 24V	A figure displayed with the AC or DC before the value represents a nominal voltage with standard tolerances (usually $\pm 15\%$) included. E.g.: DC 12V describes a 12V battery disregarding whether it is full (13.7V) or flat (10V)
24Vdc	A figure with the unit (Vdc) at the end is a momentary figure without any additional tolerances included.
may	A key word indicate flexibility of choice with no implied preference
shall	A key word indicate a mandatory requirement
should	A key word indicate flexibility of choice with a strongly preferred implementation
1+1 Redundancy	Use of two identical power supplies in parallel to provide continued operation following most failures in a single power supply. The two power supply outputs should be isolated from each other by utilizing diodes or other switching arrangements. E.g. two 10A power supplies are needed to achieve a 10A redundant system.
N+1 Redundancy	Use of three or more identical power supplies in parallel to provide continued operation following most failures in a single power supply. All power supply outputs should be isolated from each other by utilizing diodes or other switching arrangements. E.g.: To achieve a 40A redundant system, five 10A power supplies are needed in a N+1 redundant system.

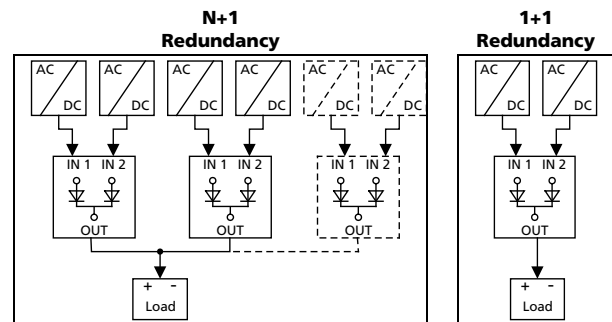

1. INTENDED USE

This device is designed for installation in an enclosure and is intended for commercial use, such as in industrial control, process control, monitoring and measurement equipment or the like. Do not use this device in equipment where malfunction may cause severe personal injury or threaten human life.

The redundancy module can be used with any type of power supply as long as the maximum output current ratings are not exceeded. It is suitable for power supplies with continuous overload current as well as any kind of intermittent (Hiccup) overload behavior

2. INSTALLATION INSTRUCTIONS

WARNING Risk of electrical shock, fire, personal injury or death.

- Turn power off before working on the device and protect against inadvertent re-powering.
- Do not open, modify or repair the device.
- Use caution to prevent any foreign objects from entering into the housing.
- Do not use in wet locations or in areas where moisture or condensation can be expected.
- Do not touch during power-on, and immediately after power-off. Hot surface may cause burns.

Obey the following installation instructions:

This device may only be installed and put into operation by qualified personnel.

This device does not contain serviceable parts. The tripping of an internal fuse is caused by an internal defect.

If damage or malfunction should occur during installation or operation, immediately turn power off and send unit to the factory for inspection.

Install the device in an enclosure providing protection against electrical, mechanical and fire hazards.

Do not ground or earth the positive output pole which could prevent redundancy in case of a ground failure. Ground the negative output pole, when needed.

Use only power supplies with a negligible output ripple voltage in the low frequency range between 50Hz and 10kHz when used in marine applications according to the GL regulations.

Install the device onto a DIN rail according to EN 60715 with the input terminals on the top of the device. Other mounting orientations require a reduction in output current.

Make sure that the wiring is correct by following all local and national codes. Use appropriate copper cables that are designed for a minimum operating temperature of 60°C for ambient temperatures up to +45°C, 75°C for ambient temperatures up to +60°C and 90°C for ambient temperatures up to +70°C. Ensure that all strands of a stranded wire enter the terminal connection.

Unused screw terminals should be securely tightened.

The device is designed for pollution degree 2 areas in controlled environments. No condensation or frost is allowed.

The enclosure of the device provides a degree of protection of IP20.

The input must be powered from a PELV or SELV source or an "Isolated Secondary Circuit" in order to maintain a SELV or PELV output.

Check correct input polarity. The device will not operate when input voltage is reversed.

The device is designed as "Class of Protection III" equipment according to IEC 61140.

A PE (ground) connection is not required. However, connecting the chassis ground terminal to ground can be beneficial to gain a high EMI immunity.

The device is designed for convection cooling and does not require an external fan. Do not obstruct airflow and do not cover ventilation grid!

The device is designed for altitudes up to 6000m (19685ft). See additional requirements in the product datasheet for use above 2000m (6560ft).

Keep the following minimum installation clearances: 40mm on top, 20mm on the bottom, 5mm left and right side. Increase the 5mm to 15mm in case the adjacent device is a heat source. When the device is permanently loaded with less than 50%, the 5mm can be reduced to zero. Under special circumstances clearances can be reduced. See details in the product datasheet.

The maximum surrounding air temperature is +70°C (+158°F). The operational temperature is the same as the ambient or surrounding air temperature and is defined 2cm below the device.

The device is designed to operate in areas between 5% and 95% relative humidity. I

Installation Instructions for Hazardous Location Areas

The device is suitable for use in Class I Division 2 Groups A, B, C, D locations and for use in Group II Category 3 (Zone 2) environments.

Hazardous Location classification: ATEX: EPS 11 ATEX 1 312 X, II 3G EX ec IIC T4 Gc

WARNING EXPLOSION HAZARDS!

Substitution of components may impair suitability for this environment. Do not disconnect the device unless power has been switched off or the area is known to be non-hazardous.

A suitable enclosure must be provided for the end product which has a minimum protection of IP54 and fulfils the requirements of the EN 60079-0.

3. INPUT AND OUTPUT CHARACTERISTICS

Number of inputs	2		
Number of outputs	1		
Input voltage	nom.	DC 12-28V \pm 30%	The input circuitry must meet the SELV requirements stipulated by IEC/EN/UL 60950-1.
Input voltage range	8.4-36.4Vdc		
Voltage drop, input to output	typ.	140mV	at 2x20A, see Fig. 3-1
	typ.	72mV	at 2x10A, see Fig. 3-1
	typ.	112mV	at 1x20A, see Fig. 3-2
Input current	nom.	2x 0-20A	continuous
	nom.	2x 20-32.5A	for 5 seconds
	max	2x 32.5A	at continuous overload or short circuit
Peak input current	max.	1000A	for max. 1ms per input
Output current	nom.	40A	continuous
	nom.	40-65A	for 5 seconds
	max.	65A	at continuous overload or short circuit
Reverse current	max.	1mA	at 24V, per input, -40°C to +70°C
Reverse voltage	max.	40Vdc	voltage applied to the output, continuously allowed
Output capacitance	typ.	320 μ F	

Note: Ensure that the continuous output current does not exceed 65A. Check the short-circuit current of the power sources and if the power source can deliver more than 65A together, use an appropriate fuse on the output.

Fig. 3-1 **Input to output voltage drop when both inputs draw current**
(typical 1+1 redundant case, when the output voltages of the two units are equal)

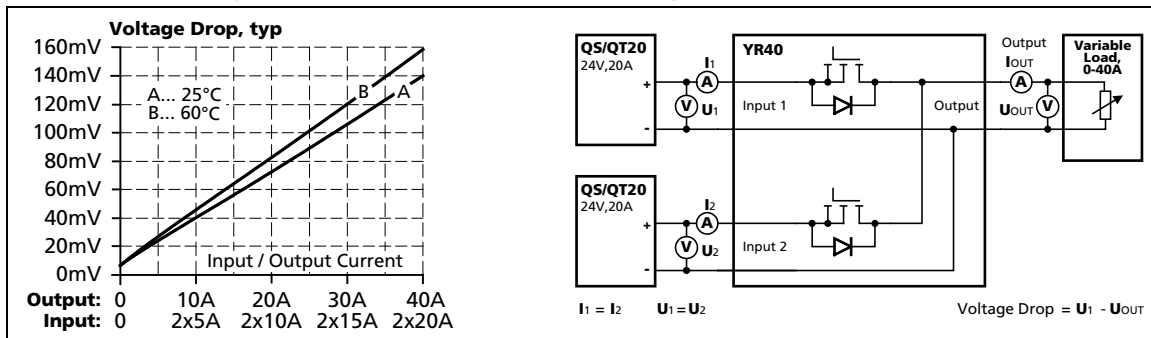
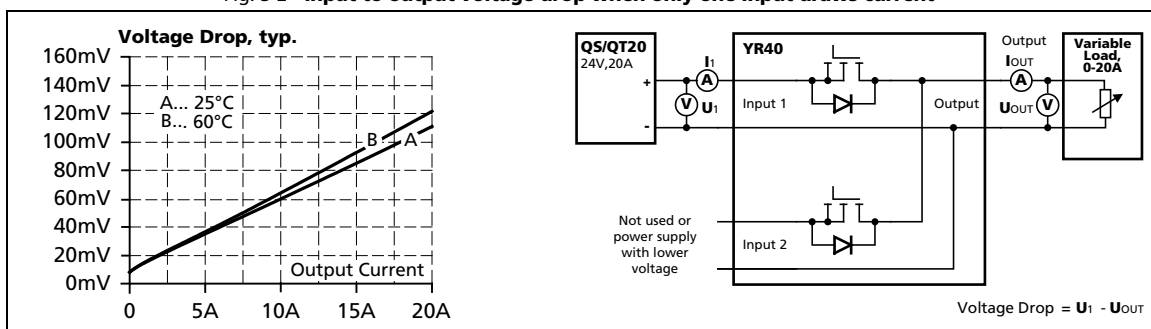

Fig. 3-2 **Input to output voltage drop when only one input draws current**



4. POWER LOSSES

DC 24V			
Power losses	typ.	2.15W	input: 2x10A
	typ.	6.3W	input: 2x20A
	typ.	2.6W	input: 1x20A, (only one input is connected to input voltage)
Standby power losses	typ.	0.35W	at no output current, (only one input is connected to input voltage)
	typ.	0.7W	at no output current, (both inputs are connected to input voltages)

Fig. 4-1 Power losses when both inputs draw equal current

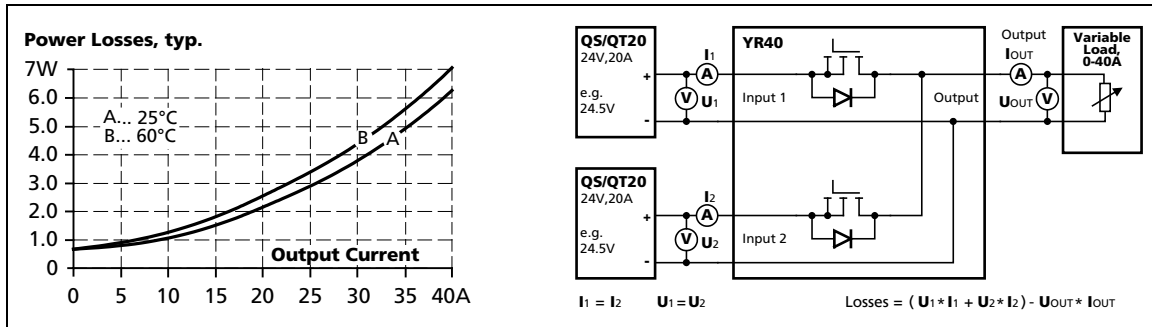
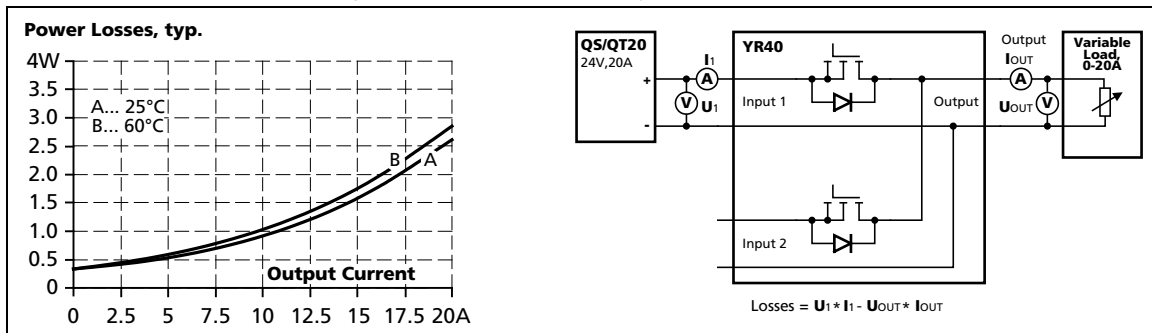

Fig. 4-2 Power losses when only one input is used



Note: As soon as voltage is applied on input 2, an additional 0.35W will be consumed. It is not relevant, whether this channel contributes to the output current or not.

5. LIFETIME EXPECTANCY AND MTBF

The redundancy module has two input channels which are completely independent from each other. Each control circuit, auxiliary voltage source, or other circuitry in the module are designed separately for each input. The dual input redundancy module can be considered as two single redundancy modules combined together in one housing. The only common point is the circuit trace that ties the two separate circuits together at the output.

The MTBF figures below are for the entire dual input module. If the MTBF number of only one path is needed, simply double the value from the table.

Input / output current conditions	Input: 2x10A Output: 20A	Input: 2x20A Output: 40A	
Lifetime expectancy*)	649 000h *)	246 000h *)	at 24V and 40°C
	1 835 000h *)	696 000h *)	at 24V and 25°C
MTBF**) SN 29500, IEC 61709	3 386 000h	2 706 000h	at 24V 40°C
	5 667 000h	4 686 000h	at 24V 25°C
MTBF**) MIL HDBK 217F	116 000h	97 000h	Ground Fixed GF40 (24V and 40°C)
	155 000h	128 000h	Ground Fixed GF25 (24V and 25°C)
	612 000h	522 000h	Ground Benign GB40 (24V and 40°C)
	813 000h	687 000h	Ground Benign GB25 (24V and 25°C)

*) The **Lifetime expectancy** shown in the table indicates the minimum operating hours (service life) and is determined by the lifetime expectancy of the built-in electrolytic capacitors. Lifetime expectancy is specified in operational hours and is calculated according to the capacitor's manufacturer specification. The manufacturer of the electrolytic capacitors only guarantees a maximum life of up to 15 years (131 400h). Any number exceeding this value is a calculated theoretical lifetime which can be used to compare devices.

) **MTBF stands for **Mean Time Between Failure**, which is calculated according to statistical device failures, and indicates reliability of a device. It is the statistical representation of the likelihood of a unit to fail and does not necessarily represent the life of a product. The MTBF figure is a statistical representation of the likelihood of a device to fail. A MTBF figure of e.g. 1 000 000h means that statistically one unit will fail every 100 hours if 10 000 units are installed in the field. However, it can not be determined if the failed unit has been running for 50 000h or only for 100h.

6. TERMINALS AND WIRING

	Input	Output
Type	Screw termination IP20 Finger safe construction. Suitable for field installation.	Screw termination IP20 Finger safe construction. Suitable for field installation.
Solid wire	0.5-6mm ²	0.5-16mm ²
Stranded wire	0.5-4mm ²	0.5-10mm ²
American Wire Gauge	20-10 AWG	22-8 AWG
Max. wire diameter	2.8mm (including ferrule)	5.2mm (including ferrule)
Wire stripping length	7mm / 0.275inch	12mm / 0.5inch
Screwdriver	3.5mm slotted or Pozidrive No 2	3.5mm slotted or Pozidrive No 2
Recommended tightening torque	0.8Nm, 7lb.in	1.2Nm, 10.6lb.in

To connect the chassis to ground, use a ring-type terminal (ring cable lug) which is suitable for a M4 screw and connect it to the chassis ground terminal on top of the unit.

Instructions:

- a) The external circuitry of all terminals must meet the safety requirements stipulated by IEC/EN/UL 60950-1: SELV.
- b) Use appropriate copper cables that are designed for minimum operating temperatures of:
 - 60°C for ambient up to 45°C and
 - 75°C for ambient up to 60°C and
 - 90°C for ambient up to 70°C minimum.
- c) Follow national installation codes and installation regulations!
- d) Ensure that all strands of a stranded wire enter the terminal connection!
- e) Screws of unused terminal compartments should be securely tightened.
- f) Ferrules are allowed.
- g) Do not connect or disconnect the wires from the terminals below -25°C (-13°F).

7. FUNCTIONAL DIAGRAM

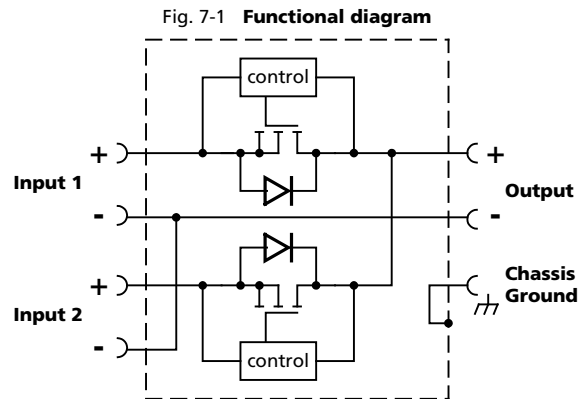

8. FRONT SIDE AND USER ELEMENTS

Fig. 8-1 **Front side**

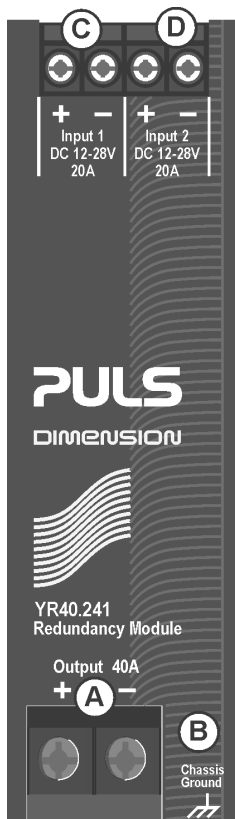

A **Output Terminals** (screw terminals)

B **Chassis Ground Terminals**

To be connected on the top side of the housing with a ring-type terminal (ring cable lug) which is suitable for a M4 screw. Connection of the chassis is optional and not required since the unit fulfills the requirements according to protection class III.

C **Input Terminals for Input 1** (screw terminals)

D **Input Terminals for Input 2** (screw terminals)

9. EMC

The redundancy module is suitable for applications in industrial environment as well as in residential, commercial and light industry environment without any restrictions. A detailed EMC report is available on request.

EMC Immunity	According generic standards: EN 61000-6-1 and EN 61000-6-2			
Electrostatic discharge	EN 61000-4-2	Contact discharge	8kV	Criterion A
		Air discharge	15kV	Criterion A
Electromagnetic RF field	EN 61000-4-3	80MHz-2.7GHz	20V/m	Criterion A
Fast transients (Burst)	EN 61000-4-4	Input lines	2kV	Criterion A
		Output lines	2kV	Criterion A
Surge voltage on input lines	EN 61000-4-5	+ → -	500V	Criterion A
		+/- → Chassis ground	1kV	Criterion A
Surge voltage on output lines	EN 61000-4-5	+ → -	500V	Criterion A
		+/- → Chassis ground	1kV	Criterion A
Conducted disturbance	EN 61000-4-6	0.15-80MHz	20V	Criterion A
Power-frequency magnetic field *)	EN 61000-4-8	50Hz	30A/m	Criterion A

Criteria:

A: Redundancy module shows normal operation behavior within the defined limits.

Notes:

*) A test is not applicable according to EN 61000-6-2, since the device does not contain components susceptible to magnetic fields, e.g. hall elements, electrodynamic microphones, etc.

EMC Emission	According generic standards: EN 61000-6-3 and EN 61000-6-4	
Conducted emission	IEC/CISPR 16-1-2, IEC/CISPR 16-2-1	limits for DC power ports according EN 61000-6-3 fulfilled *)
Radiated emission	EN 55011, EN 55032	Class B

This device complies with FCC Part 15 rules.

Operation is subjected to following two conditions: (1) this device may not cause harmful interference, and (2) this device must accept any interference received, including interference that may cause undesired operation.

*) For information only, not mandatory for EN 61000-6-3. Provided, that power sources connected on the inputs fulfill the requirements too.

Switching frequency	The internal auxiliary supply is generated with a boost converter. The switching frequency is typ. 16kHz.
----------------------------	--

10. ENVIRONMENT

Operational temperature *)	-40°C to +70°C (-40°F to 158°F)	
Storage temperature	-40 to +85°C (-40°F to 185°F)	for storage and transportation
Humidity **)	5 to 95% r.H.	IEC 60068-2-30
Vibration sinusoidal ***)	2-17.8Hz: ±1.6mm; 17.8-500Hz: 2g 2 hours / axis	IEC 60068-2-6
Shock ***)	30g 6ms, 20g 11ms 3 bumps / direction, 18 bumps in total	IEC 60068-2-27
Altitude	0 to 2000m (0 to 6 560ft) 2000 to 6000m (6 560 to 20 000ft)	without any restrictions reduce output power or ambient temperature, see Fig. 10-2
Altitude derating	2.5A/1000m or 5°C/1000m	> 2000m (6500ft), see Fig. 10-2
Over-voltage category	not applicable	The concept of the overvoltage category is used for equipment energized directly from the low voltage mains (IEC 60664-1 §4.3.3.2.1).
Degree of pollution	2	IEC 62103, EN 50178, not conductive

*) Operational temperature is the same as the ambient temperature and is defined as the air temperature 2cm below the unit.

**) Do not energize while condensation is present

***) Tested in combination with DIN rails according to EN 60715 with a height of 15mm and a thickness of 1.3mm and standard mounting orientation.

Fig. 10-1 Output current vs. ambient temp.

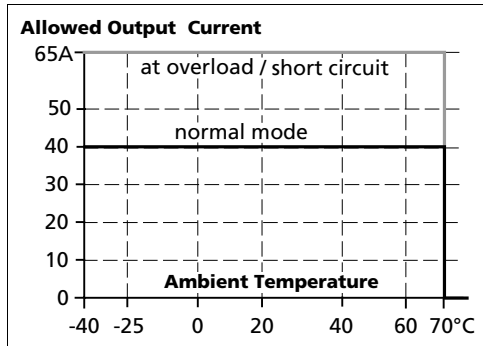
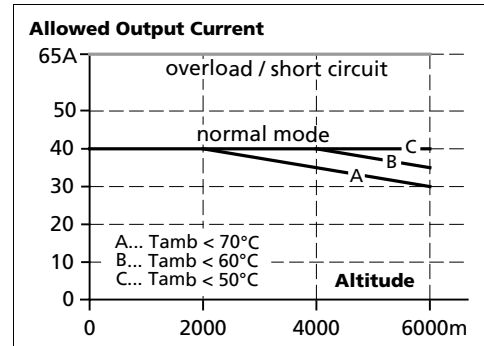

Fig. 10-2 Output current vs. altitude



11. PROTECTION FEATURES

Output over-current protection	not included	
Reverse input polarity protection	included	unit does not start when input voltage is reversed
Degree of protection	IP 20	EN/IEC 60529
Penetration protection	> 3.6mm	e.g. screws, small parts
Over-temperature protection	not included	
Input transient protection	not included	
Output transient protection	included	see EMC chapter
Internal input fuse	not included	

12. SAFETY FEATURES

Input / output separation	no galvanic separation	Mosfet between input and output
Class of protection	III	PE (Protective Earth) or chassis connection not required
PE resistance	< 0.10hm	between housing and chassis-ground terminal

13. DIELECTRIC STRENGTH

The input and output voltages have the same reference, are floating and have no ohmic connection to ground. Type and factory tests are conducted by the manufacturer. Field tests may be conducted in the field using the appropriate test equipment which applies the voltage with a slow ramp (2s up and 2s down). Connect input/output terminals together before conducting the test.





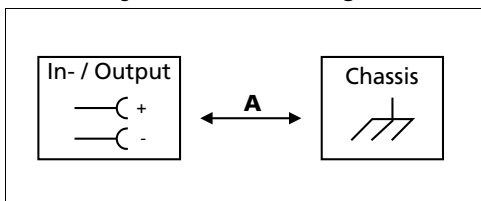

When testing, set the cut-off current settings to the value in the table below.

Fig. 13-1 Dielectric strength



		A
Type test	60s	500Vac
Factory test	5s	500Vac
Field test	5s	500Vac
Cut-off current setting		> 2mA

14. APPROVED, FULFILLED OR TESTED STANDARDS

UL 508		UL Certificate Listed equipment for category NMTR - Industrial Control Equipment Applicable for US and Canada E-File: E198865
IEC 60950-1	CB Report	CB Scheme Certificate General safety requirements for Information Technology Equipment (ITE)
UL 60950-1		UL Certificate Recognized component for category QQQ - Information Technology Equipment (ITE) Applicable for US and Canada E-File: E137006
ATEX		Agency Certificate (Bureau Veritas) EN 60079-0 Explosive atmospheres - General requirements EN 60079-7 Equipment protection by type of protection "e" Certificate: EPS 11 ATEX 1 312 X Temperature Code: T4 Type of Protection: ec
IECEX	IECEX	IECEX Certificate IEC 60079-0 Explosive atmospheres - General requirements IEC 60079-7 Equipment protection by type of protection "e" Certificate: IECEX EPS 12.0032 X Temperature Code: T4 Type of Protection: ec
Class I Div 2		CSA Certificate Power Supplies for Hazardous Location Applicable for Canada and US CSA Class: 5318-01 (Canada), 5318-81 (USA) Temperature Code: T4 Groups: A, B, C and D
Marine (DNV)		DNV Certificate DNV Type approved product Certificate: TAA00002YX Temperature: Class D Humidity: Class B Vibration: Class C EMC: Class B Enclosure: Class A
Marine (ABS)	ABS	ABS Design Assessment Certificate ABS (American Bureau of Shipment) assessed product Certificate: 17-HG1599236-PD
IEC 60068-2-60	Corrosion IEC 60068-2-60 Method 4 	Manufacturer's Declaration (Online Document) Environmental Tests, Flowing Mixed Gas Corrosion Test Test Ke - Method 4 H2S: 10ppb NO2: 200ppb Cl2: 10ppb SO2: 200ppb Test Duration: 3 weeks, which simulates a service life of 10 years.

ISA-71.04-1985

Corrosion
G3-ISA-71.04 ✓

Manufacturer's Declaration (Online Document)
Airborne Contaminants Corrosion Test
Severity Level: G3 Harsh
H2S: 100ppb
NOx: 1250ppb
Cl2: 20ppb
SO2: 300ppb
Test Duration: 3 weeks, which simulates a service life of 10 years

VDMA 24364

LABS
VDMA 24364-C1-L/W

Paint Wetting Impairment Substances Test (or LABS-Test)
Tested for Zone 2 and test class C1 according to VDMA 24364-C1-L/W for solvents and water-based paints

15. REGULATORY PRODUCT COMPLIANCE

EU Declaration of Conformity



The CE mark indicates conformance with the
- EMC directive
- ATEX directive
- RoHS directive

REACH Directive

REACH ✓

Manufacturer's Statement
EU-Directive regarding the Registration, Evaluation, Authorization and Restriction of Chemicals

WEEE Directive



Manufacturer's Statement
EU-Regulation on Waste Electrical and Electronic Equipment
Registered in Germany as business to business (B2B) products.

KC Korean Certificate



KC Registration
Korean registration of Broadcasting and Communication Equipment
Registered under Clause 3, Article 58-2 of Radio Waves Act.

EAC TR Registration



EAC Certificate
EAC EurAsian Conformity - Registration Russia, Kazakhstan and Belarus
8504408200, 8504409000

16. PHYSICAL DIMENSIONS AND WEIGHT

Weight	340g / 0.75lb
DIN rail	Use 35mm DIN rails according to EN 60715 or EN 50022 with a height of 7.5 or 15mm. The DIN rail depth must be added to the unit depth (127mm) to calculate the total required installation depth.
Installation clearances	See chapter 2

Fig. 16-1 **Front view**

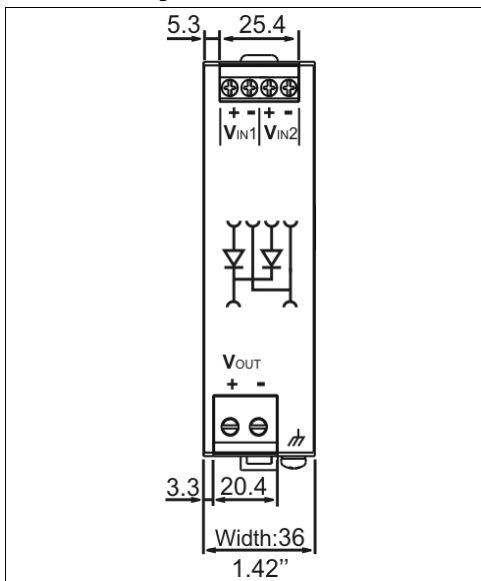
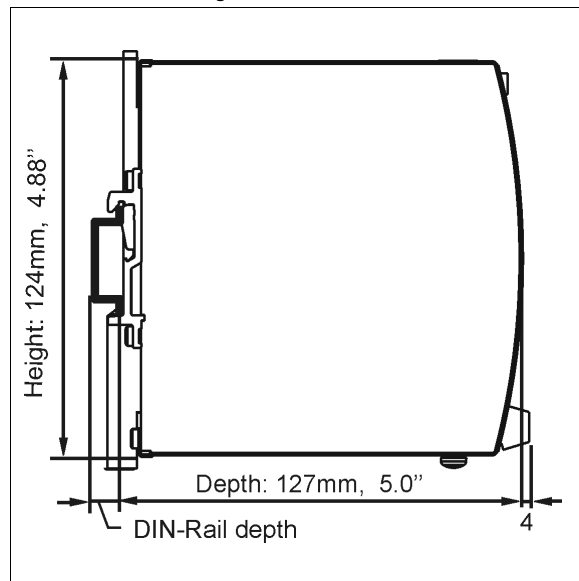

Fig. 16-2 **Side view**



17. ACCESSORIES

17.1. ZM2.WALL - WALL-MOUNTING BRACKET

This standard bracket is used to mount the YR40.241 redundancy module onto a flat surface without utilizing a DIN rail.

Fig. 17-1 **ZM2.WALL** Wall mounting bracket

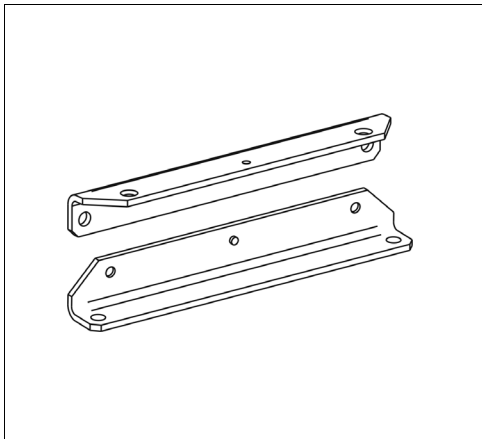
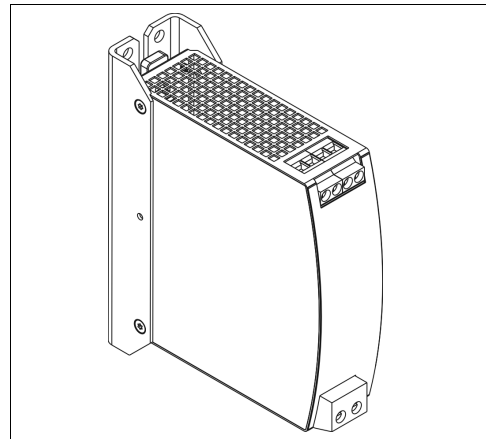

Fig. 17-2 **Assembled wall mounting bracket**



17.2. ZM11.SIDE - SIDE MOUNTING BRACKET

This bracket is used to mount the YR40.241 redundancy module sideways with or without utilizing a DIN rail.

The two aluminum brackets and the black plastic slider of the unit have to be detached, so that the steel brackets can be mounted.

For sideways DIN rail mounting, the removed aluminum brackets and the black plastic slider need to be mounted on the steel bracket.

Fig. 17-3
ZM11.SIDE Side mounting bracket

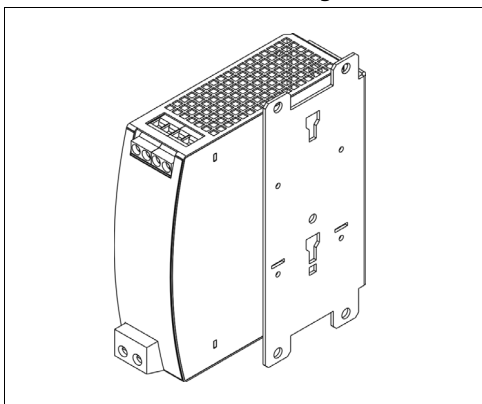
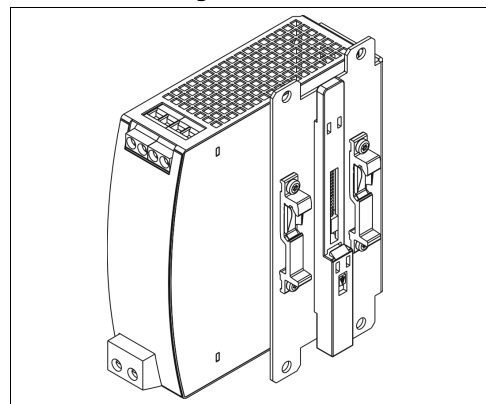

Fig. 17-4
Side mounting with DIN rail brackets



18. APPLICATION NOTES

18.1. RECOMMENDATIONS FOR REDUNDANCY

Recommendations for the configuration of redundant power systems:

- Use separate input fuses for each power supply.
- Use three-phase power supplies to gain functional safety if one phase fails.
- When single-phase power supplies are utilized connect them to different phases or mains circuits if possible.
- Set the power supply in "Parallel-Use" mode if this feature is available
- It is desirable to set the output voltages of all power supplies to the same value.

18.2. INDUCTIVE AND CAPACITIVE LOADS

The unit is designed to supply any kind of loads, including unlimited capacitive and inductive loads.

18.3. SIDEWARD INSTALLATION CLEARANCES

The minimum clearance recommendations are defined in chapter 2.

Normally, the following installation clearance are recommended: 40mm on top, 20mm on the bottom, 5mm on the left and right sides when the device is loaded permanently with more than 50% of the rated power. Increase this clearance to 15mm in case the adjacent device is a heat source (e.g. another power supply).

The clearance between the power supplies and the redundancy module can be reduced to zero under the following conditions:

- 1+1 redundancy application with maximum 20A output current.
- The power supplies are from the PULS DIMENSION series.
- The redundancy module is placed between the two power supplies.
- The output voltage is set to the same level on both power supplies.

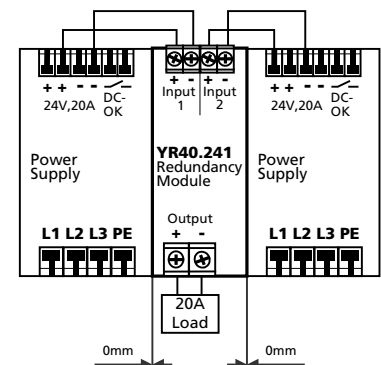

18.4. 1+1 REDUNDANCY UP TO 20A

1+1 Redundancy up to 20A requires two 20A power supplies and one YR40.241 redundancy module.

Fig. 18-1 **Wiring diagram, 1+1 Redundancy, 20A output current**

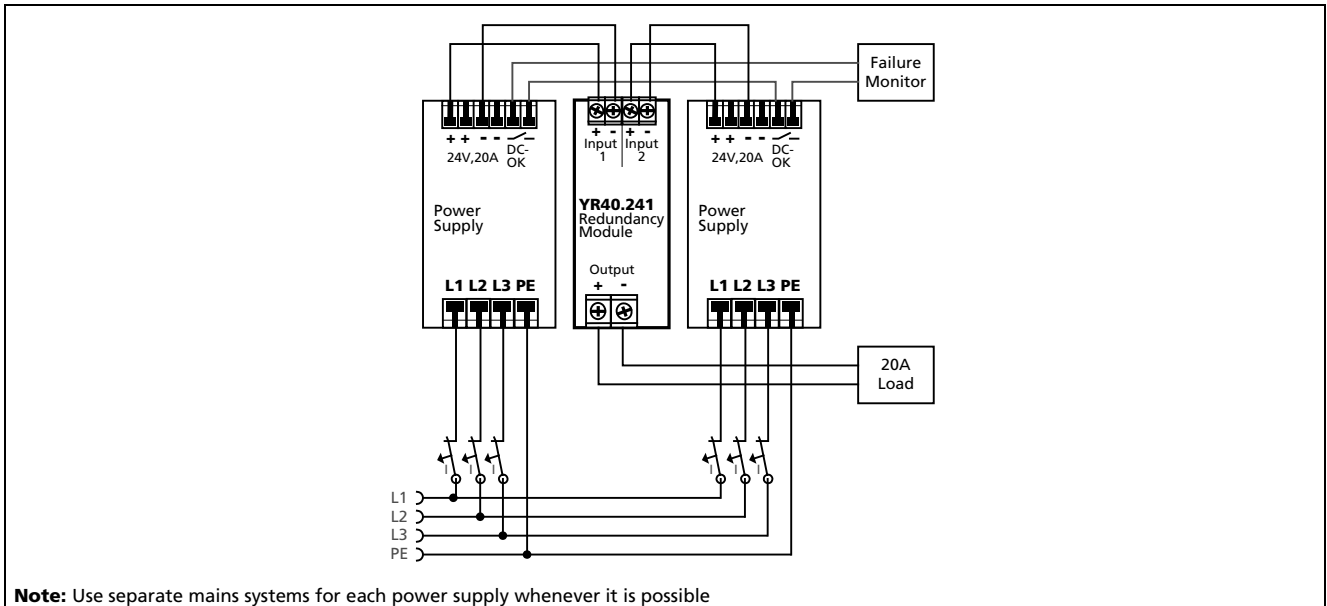

18.5. N+1 REDUNDANCY, EXAMPLE WITH 60A

N+1 Redundancy up to 60A requires four 20A power supplies and two YR40.241 redundancy modules.

Fig. 18-2 **Wiring diagram, n+1 Redundancy, 60A output current**

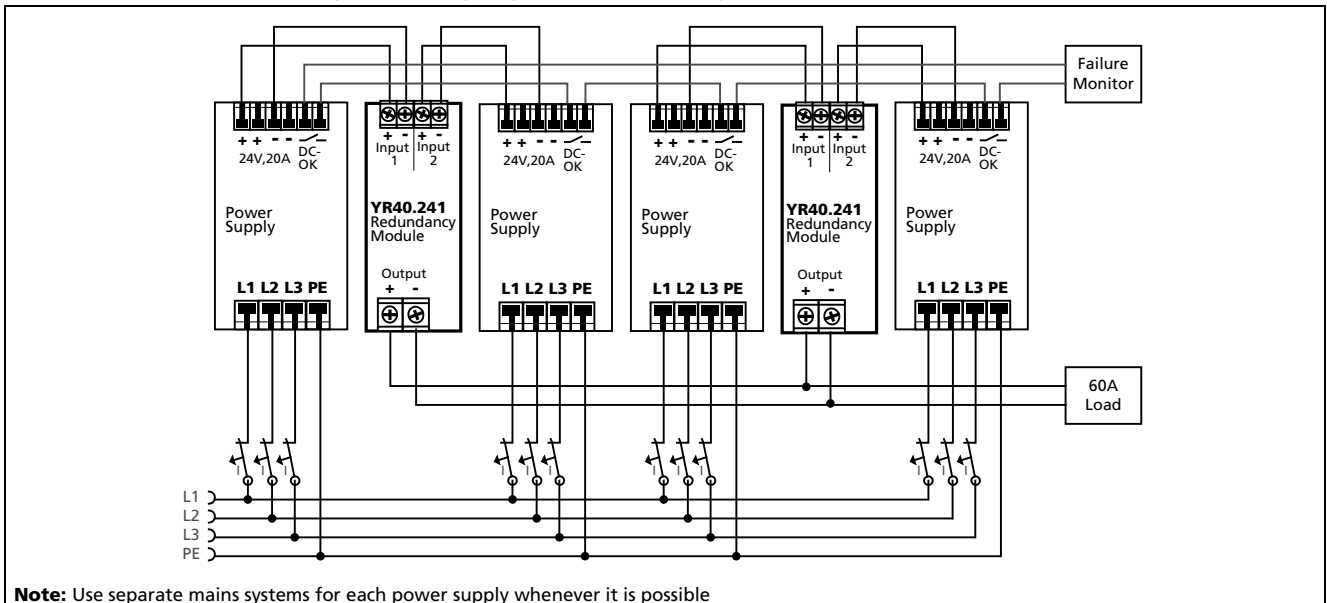

18.6. MOUNTING ORIENTATIONS

Mounting orientations other than input terminals on the bottom and output on the top require a reduction in continuous output power or a limitation in the maximum allowed ambient temperature. The amount of reduction influences the lifetime expectancy of the power supply. Therefore, two different derating curves for continuous operation can be found below:

Curve A1 Recommended output current.

Curve A2 Max allowed output current (results in approximately half the lifetime expectancy of A1).

Fig. 18-3
Mounting Orientation A
(Standard orientation)

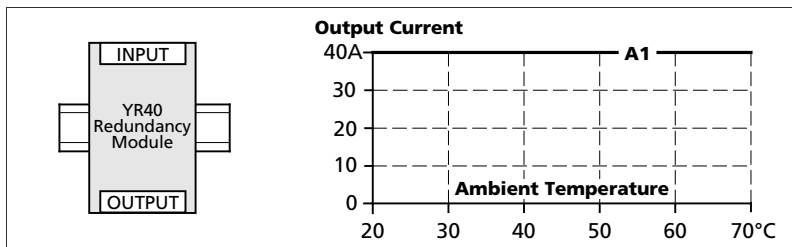

Fig. 18-4
Mounting Orientation B
(Upside down)

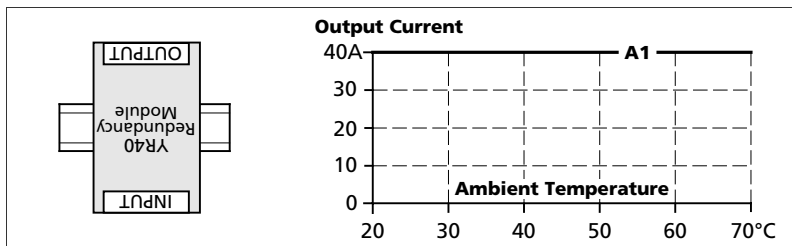

Fig. 18-5
Mounting Orientation C
(Table-top mounting)

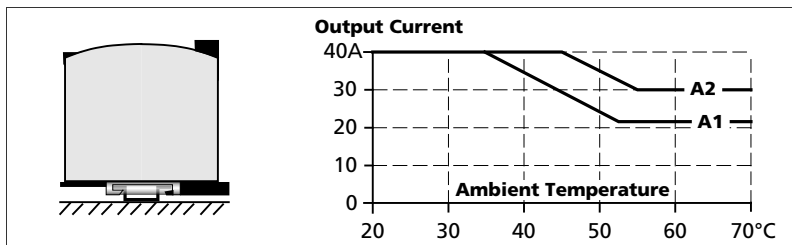

Fig. 18-6
Mounting Orientation D
(Horizontal cw)

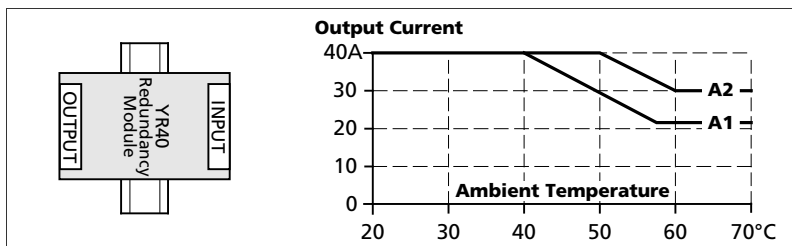

Fig. 18-7
Mounting Orientation E
(Horizontal ccw)

