

**POWER SUPPLY 100-240 Vac 24 V 188 W**

- IP65 and IP67 degree of protection
- AC 100-240 V wide-range input
- 2 independent output converters
- 2 NEC Class 2 outputs
- Output connected to PE (PELV/ES1)
- 95.1 % full load and excellent partial load efficiencies
- Full power between -30 °C and +45 °C
- Negligibly low input inrush current surge
- High immunity to transients and power surges
- Low electromagnetic emissions
- IO-Link interface
- 3 year warranty

**PRODUCT DESCRIPTION**

The FPS202 is an industrial grade power supply for a 1-phase mains system that is incorporated into a rugged wall-mount housing with an IP65 and IP67 degree of protection.

It provides 2 stabilised, galvanically isolated output channels, which are also electrically isolated from the input. The negative terminals of the outputs are permanently connected to PE within the unit.

The most outstanding features of the FPS series are compact size, wide operating temperature range, extremely low input inrush current and very high efficiencies, which are achieved through various design topologies.

High immunity to transients and power surges as well as low electromagnetic emissions and an international approval package make the use in nearly every application possible.

**SHORT-FORM DATA**

|                    |  |                      |
|--------------------|--|----------------------|
| Output voltage     | DC 24 V                                  | nominal              |
| Adjustment range   | 24-28 V                                  | factory setting 24 V |
| Total output power | 188 W                                    | for all outputs      |
| Output power       | 2x 94 W                                  | up to +45 °C ambient |
|                    | 2x 60 W                                  | up to +70 °C ambient |
| Short term (4 s)   | 2x 150 W                                 | up to +45 °C ambient |
|                    | 2x 90 W                                  | up to +70 °C ambient |
|                    | Derate linearly between +45 °C to +70 °C |                      |
| Number of outputs  | 2  |                      |
| Output currents    | NEC Class 2                              | 3.9-3.4 A            |
| Input voltage AC   | AC 100-240 V                             | -15 / +10 %          |
| Power factor       | 0.98 / 0.96                              | at 120 / 230 Vac     |
| AC Inrush current  | 8 / 4 A <sub>peak</sub>                  | at 120 / 230 Vac     |
| Efficiency         | 93.9 / 95.1 %                            | at 120 / 230 Vac     |
| Power Losses       | 12.5 / 10 W                              | at 120 / 230 Vac     |
| Hold-up time       | 38 / 38 ms                               | at 120 / 230 Vac     |
| Temperature range  | -30 °C to +70 °C                         |                      |
| Size (wxhxd)       | 166x153x59 mm                            | without connectors   |
| Weight             | 790 g                                    |                      |

**ORDER NUMBERS**

|                           |              |               |
|---------------------------|--------------|---------------|
| <b>FPS202.242-004-IOL</b> | Power supply |               |
|                           | <b>Input</b> | <b>Output</b> |
|                           | M12-S 3pin   | M12-A 5pin    |

**MAIN APPROVALS**

For details and a complete approval list, see chapter 20.



IEC 62368-1  
IEC 61010-2-201

UL 61010

## 1. Index

|    |                                  |    |      |  |    |
|----|----------------------------------|----|------|--|----|
| 1  | Index.....                       | 2  | 16   | EMC.....                                     | 15 |
| 2  | Intended Use.....                | 4  | 17   | Environment.....                             | 17 |
| 3  | Installation Instructions.....   | 4  | 18   | Safety and Protection Features.....          | 18 |
| 4  | AC Input.....                    | 5  | 19   | Dielectric Strength.....                     | 19 |
| 5  | DC Input.....                    | 6  | 20   | Approved, Fulfilled or Tested Standards..... | 20 |
| 6  | Input Inrush Current.....        | 6  | 21   | Regulatory Product Compliance.....           | 21 |
| 7  | Output.....                      | 7  | 22   | Application Notes.....                       | 22 |
| 8  | Hold-up Time.....                | 8  | 22.1 | Repetitive Pulse Loading.....                | 22 |
| 9  | IO-Link Interface.....           | 9  | 22.2 | External Input Protection.....               | 22 |
| 10 | Efficiency and Power Losses..... | 10 | 22.3 | Inductive and Capacitive Loads.....          | 22 |
| 11 | Lifetime Expectancy.....         | 11 | 22.4 | Back-Feeding Loads.....                      | 22 |
| 12 | MTBF.....                        | 11 | 22.5 | Parallel Use to Increase Output Power.....   | 22 |
| 13 | Functional Diagram.....          | 12 | 22.6 | Series Operation.....                        | 22 |
| 14 | Dimensions and Connectors.....   | 13 | 22.7 | Mounting Orientations.....                   | 23 |
| 15 | User Interface.....              | 14 |      |  |    |

The information given in this document is correct to the best of our knowledge and experience at the time of publication. If not expressly agreed otherwise, this information does not represent a warranty in the legal sense of the word. As the state of our knowledge and experience is constantly changing, the information in this datasheet is subject to revision. We therefore kindly ask you to always use the latest issue of this document (available under [www.pulspower.com](http://www.pulspower.com)).

No part of this document may be reproduced or utilized in any form without our prior permission in writing.

Packaging and packaging aids can and should always be recycled. The product itself may not be disposed of as domestic refuse.

## Terminology and Abbreviation

|  |   |
|--|---|
| <b>PE and <math>\oplus</math> Symbol</b> | PE is the abbreviation for <b>Protective Earth</b> and has the same meaning as the symbol $\oplus$ .  |
| <b>FE, Earth, Ground (GND)</b>           | This document uses the term "earth" which is the same as the U.S. term "ground".  |
| <b>t.b.d.</b>                            | To be defined, value or description will follow later.  |
| <b>100 V</b>                             | A figure displayed with the AC or DC before the value represents a nominal voltage with standard tolerances (usually $\pm 15\%$ ) included.<br>E.g.: DC 12 V describes a 12 V battery disregarding whether it is full (13.7 V) or flat (10 V) |
| <b>100 Vac</b>                           | A figure with the unit (Vac) at the end is a momentary figure without any additional tolerances included.   |
| <b>50 Hz vs. 60 Hz</b>                   | As long as not otherwise stated, AC 100 V and AC 230 V parameters are valid at 50 Hz mains frequency. AC 120 V parameters are valid for 60 Hz mains frequency.  |
| <b>may</b>                               | A key word indicating flexibility of choice with no implied preference.   |
| <b>shall</b>                             | A key word indicating a mandatory requirement.  |
| <b>should</b>                            | A key word indicating flexibility of choice with a strongly preferred implementation.   |

Nomenclature

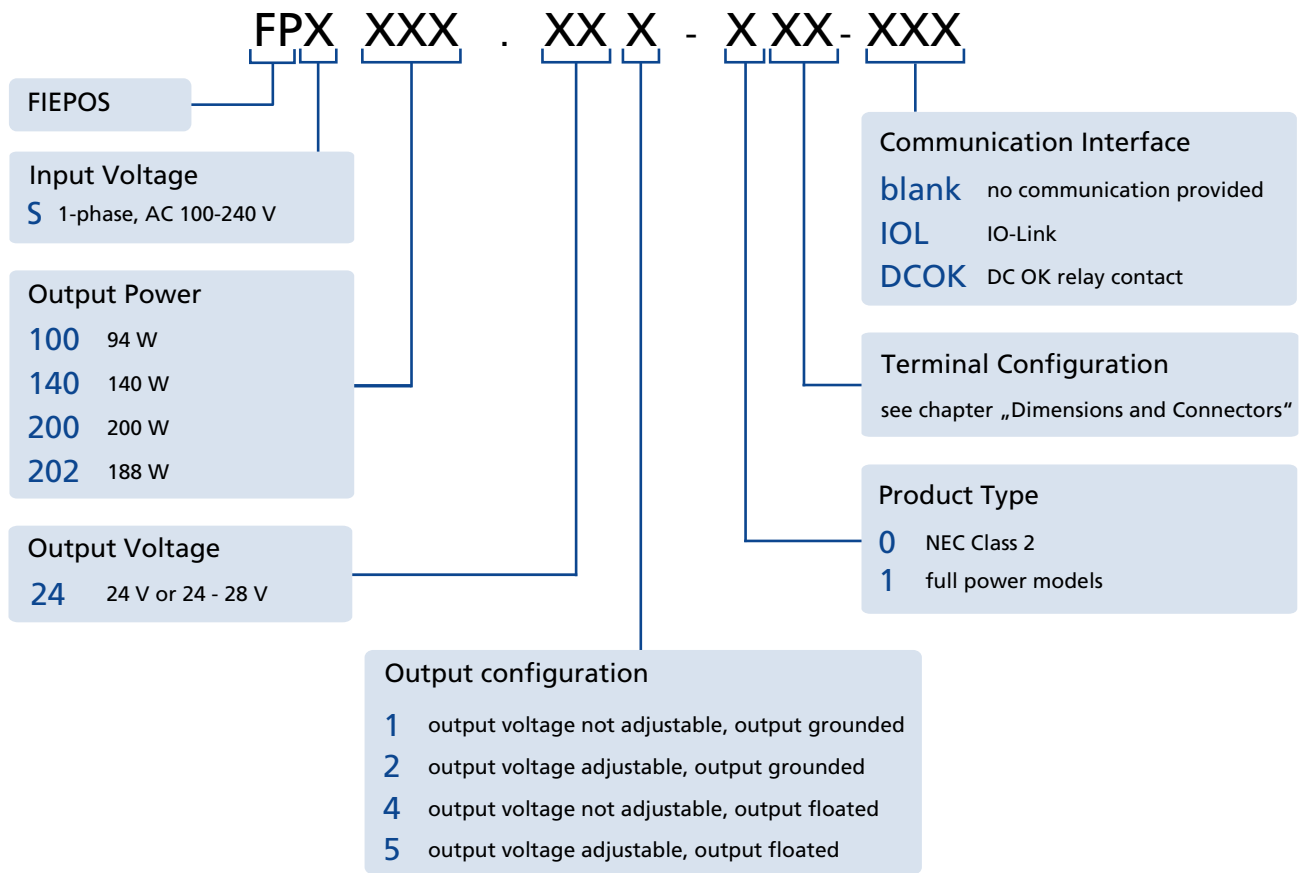

## 2. Intended Use

This device is designed for indoor use and is intended for commercial use, such as in industrial control, process control, monitoring and measurement equipment.

Do not use this device in equipment where malfunction may cause severe personal injury or threaten human life. If this device is used in a manner outside of its specification, the protection provided by the device may be impaired.

## 3. Installation Instructions

**⚠ DANGER** Risk of electrical shock, fire, personal injury or death

- Turn power off before working on the device. Protect against inadvertent re-powering.
- Do not open, modify or repair the device.
- Do not open the unit as high voltages are present inside.
- Do not touch during power-on and immediately after power-off. Hot surfaces may cause burns.
- Install the device on a large enough flat surface. Sharp edges on the back may cause injury.
- If damage or malfunction occur during installation or operation, immediately turn power off and send unit to the factory for inspection.
- The device is designed as “Class of Protection I” equipment according to IEC 61140. Do not use without a proper PE (Protective Earth) connection.

**⚠ WARNING** Risk of damages to the device

- Keep the following minimum installation clearances: 50 mm on top and 10 mm on the left and right side.
- The maximum surrounding air temperature is +70 °C. The operational temperature is the same as the ambient or surrounding air temperature and is defined 3 cm below the device.
- The device is designed to operate in areas between 5 % and 95 % relative humidity.
- Clean only with a damp cloth.

### Obey the following installation instructions:

This device may only be installed and put into operation by qualified personnel. This device does not contain serviceable parts. The tripping of an internal input fuse is caused by an internal defect. Install the device onto a flat surface with the terminals on the bottom of the device. Other mounting orientations require a reduction in output power, see chapter Mounting Orientations.

For wall mounting use 4 screws. Two on top and 2 on bottom mounting holes. Recommended screw size is M4 (UNC 8-32). The enclosure of the device provides a degree of protection of IP65 and IP67 when installed with all mating connectors firmly connected. The device is designed for pollution degree 2 areas in controlled environments.

Assure that during installation no moisture or dirt gets into the connections. Operation in areas where moisture or condensation can be expected is possible.

The negative potential of the outputs is permanently connected to PE within the unit. Do not connect the negative potential of any output to PE outside the unit.

For TN-, TT-mains systems with earthed neutral and IT star mains systems with insulation monitoring the device is designed for overvoltage category III zones up to 2000 m and for overvoltage category II zones up to 5000 m.

For TN-, TT-, IT-delta mains systems or IT star mains systems without insulation monitoring the device is intended for overvoltage category II zones up to 2000 m.

The device is designed for altitudes up to 5000 m. Above 2000 m a reduction in output current is required and the operation is limited according mains systems described above. The device is designed, tested and approved for branch circuits up to 32 A (UL) and 32 A (IEC) without additional protection device. If an external fuse is utilized, do not use circuit breakers smaller than 6 A (type B- or C-characteristic) to avoid an unintentional tripping. A disconnecting means shall be provided for the input of the device. This must be suitably located and easily accessible. The disconnecting means must be marked as such for the device.

## 4. AC Input

The device is suitable to be supplied from TN-, TT- or IT-mains networks. For more details, see chapter 3.

|                                   |                                  |                                  |
|-----------------------------------|----------------------------------|----------------------------------|
| AC input voltage rated range nom. | AC 100-240 V                     | -15 / +10 %                      |
| AC input operating range          | 85-264 Vac                       |                                  |
|                                   | 264-310 Vac                      | for max. 1000 ms                 |
| Input frequency                   | nom. 50-60 Hz                    | ±6 %                             |
| Turn-on voltage                   | typ. 83 Vac                      | steady-state value, see Fig. 4-1 |
| Shut-down voltage                 | typ. 74 Vac                      | steady-state value, see Fig. 4-1 |
| External input protection         | see recommendations in chapter 3 |                                  |

|                              |      | AC 100 V | AC 120 V | AC 230 V |   |
|------------------------------|------|----------|----------|----------|---|
| Input current                | typ. | 2.1 A    | 1.75 A   | 0.92 A   | at 2x 94 W, see Fig. 4-3                              |
| Power factor <sup>1)</sup>   | typ. | 0.98     | 0.98     | 0.96     | at 2x 94 W, see Fig. 4-4                              |
| Start-up delay Output 1 typ. |      | 1250 ms  | 1250 ms  | 1250 ms  | at 2x 94 W, see Fig. 4-2                              |
| Start-up delay Output 2 typ. |      | 1750 ms  | 1750 ms  | 1750 ms  |   |
| Rise time                    | typ. | 15 ms    | 15 ms    | 15 ms    | at 2x 94 W, const. current load, 0 mF, see Fig. 4-2   |
|                              | typ. | 35 ms    | 35 ms    | 35 ms    | at 2x 94 W, const. current load, 3.3 mF, see Fig. 4-2 |
| Turn-on overshoot            | max. | 200 mV   | 200 mV   | 200 mV   | see Fig. 4-2  |

1) The power factor is the ratio of the true (or real) power to the apparent power in an AC circuit.

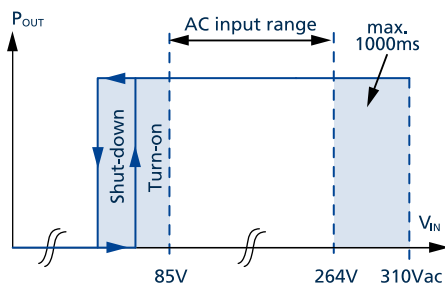

Fig. 4-1: Input voltage range

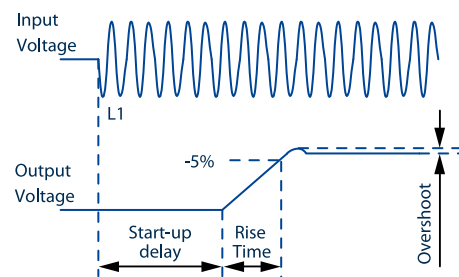

Fig. 4-2: Turn-on behaviour, definitions

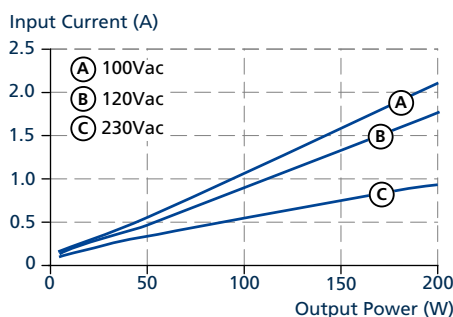

Fig. 4-3: Input current vs. output power at 24 V output voltage

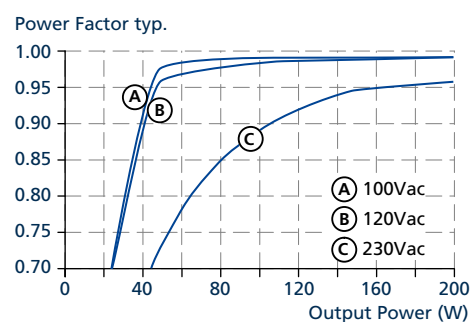

Fig. 4-4: Power factor vs. output power at 24 V output voltage

## 5. DC Input

Do not operate this power supply with DC input voltage.

## 6. Input Inrush Current

An active inrush limitation circuit (NTCs, which are bypassed by a relay contact) limits the input inrush current after turn-on of the input voltage. The charging current into EMI suppression capacitors is disregarded in the first microseconds after switch-on.

|                |      | AC 100 V            | AC 120 V            | AC 230 V            |
|----------------|------|---------------------|---------------------|---------------------|
| Inrush current | max. | 9 A <sub>peak</sub> | 8 A <sub>peak</sub> | 4 A <sub>peak</sub> |

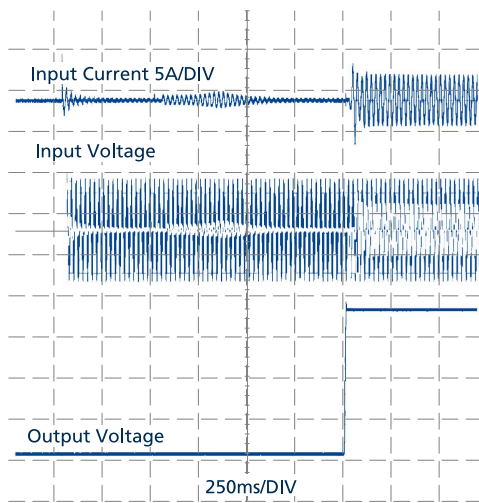

Fig. 6-1: Typical turn-on behaviour at nominal load and +25 °C ambient temperature

## 7. Output

The outputs provide a (PELV/ES1) rated voltage, which is galvanically isolated from the input voltage. The negative potential of the outputs is permanently connected to PE within the unit. Do not connect any output to PE (Ground).

The device is designed to supply any kind of loads, including capacitive and inductive loads. If capacitors with a capacitance > 100 mF are connected to the output, the unit might charge the capacitor in overcurrent mode.

**All values provided in this chapter are specified per output unless stated otherwise.**

|                                  |      |   |   |
|----------------------------------|------|---|---|
| Number of outputs                |      | 2   | 2 independent output converters   |
| Output voltage                   | nom. | 24 V  |   |
| Adjustment range                 |      | 24-28 V   | adjustable via IO-Link  |
| Factory settings                 | typ. | 24 V  | ±1 %  |
| Line regulation                  | max. | 10 mV   | between 85 and 310 Vac input voltage change   |
| Load regulation                  | max. | 50 mV   | between 0 and 2x 94 W output load, static value   |
| Ripple and noise voltage         | max. | 60 mVpp   | bandwidth 20 Hz to 20 MHz, 50 Ohm   |
| Output current                   |      | NEC Class 2   | 3.9-3.4 A   |
| Output power                     | nom. | 94 W  | up to +45 °C ambient temperature  |
|                                  | nom. | 60 W  | up to +70 °C ambient temperature  |
| Short term up to 4 s             | nom. | 150 W   | up to +45 °C ambient temperature  |
|                                  | nom. | 90 W  | up to +70 °C ambient temperature  |
|                                  |      | Derate linearly between +45 °C and +70 °C, see Fig. 17-1. |   |
| Overload / short-circuit current | typ. | 7.5 A / 0 A   | At heavy overloads (when output voltage falls below 13 V), the power supply delivers continuous output current for 2 s. After this, the output is switched off for approx. 18 s before a new start attempt is automatically performed. This cycle is repeated as long as the overload exists. Once the overload has been cleared, the device will operate normally, see Fig. 7-2. Load impedance 10 mOhm. Discharge current of output capacitors is not included. |
| Output capacitance               | typ. | 1 760 µF  | included inside the power supply  |
| Back-feeding loads               | max. | 35 V / 0.5 J  | The unit is resistant and does not show a malfunction when a load feeds back voltage to the power supply. It does not matter whether the power supply is on or off.   |

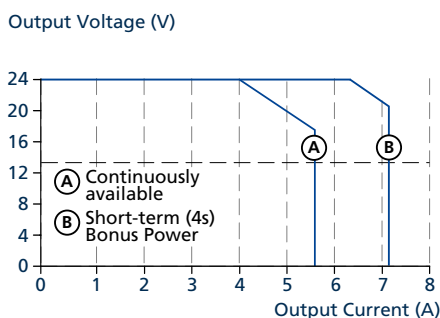

Fig. 7-1: Output voltage vs. output current

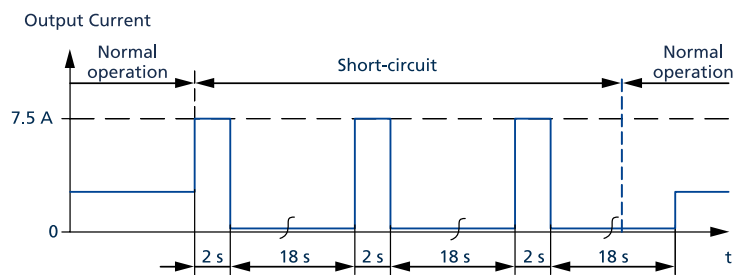

Fig. 7-2: Short-circuit on output, overcurrent mode, typ.

## 8. Hold-up Time

The hold-up time is the time during which a power supply's output voltage remains within specification following the loss of input power. The hold-up time is output load dependent. At no load, the hold-up time can be up to several seconds. The LED is also on during this time.

|              |      | AC 100 V | AC 120 V | AC 230 V |                                      |
|--------------|------|----------|----------|----------|--------------------------------------|
| Hold-up time | typ. | 61 ms    | 61 ms    | 61 ms    | at 2x 50 W output load, see Fig. 8-1 |
|              | min. | 50 ms    | 50 ms    | 50 ms    | at 2x 50 W output load, see Fig. 8-1 |
|              | typ. | 38 ms    | 38 ms    | 38 ms    | at 2x 94 W output load, see Fig. 8-1 |
|              | min. | 25 ms    | 25 ms    | 25 ms    | at 2x 94 W output load, see Fig. 8-1 |

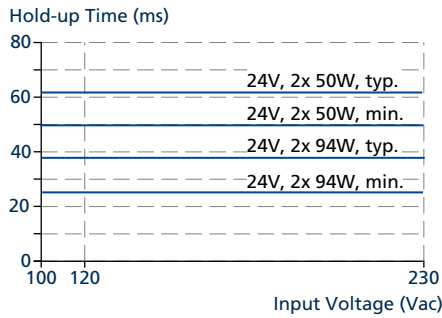

Fig. 8-1: Hold-up time vs. input voltage

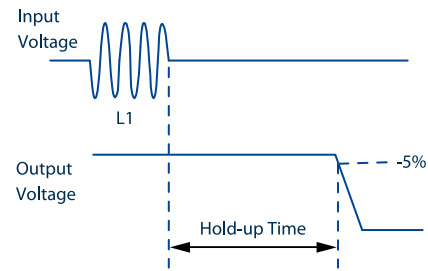

Fig. 8-2: Shut-down behaviour, definitions

## 9. IO-Link Interface

The power supply features an IO-Link interface compliant with IO-Link protocol V1.1 and can be connected to any IO#Link master supporting this standard. IO-Link enables transparent, bidirectional data communication, allowing easy and detailed monitoring of the power supply’s operating status via the control system.

The device operates independently of the IO-Link connection; if no IO-Link master is present, normal operation continues without any interruption. An integrated EEPROM stores configuration data internally, ensuring that all parameters are retained and automatically restored after power cycling.

To enable operation of the IO-Link interface, the corresponding IODD (IO-Link Device Description) file must be installed in the connected IO-Link master.



The latest version of the IODD file is available for download from the PULS website ([www.pulspower.com](http://www.pulspower.com)) in the download section of the individual product page and in the IODD Finder (<https://ioddfinder.io-link.com>). The device remains accessible via the IO-Link interface even when the power supply is switched off and not connected to the AC mains.

|                        |  |  |
|------------------------|--|--|
| IO-Link version        | V1.1   |  |
| IO-Link master version | V1.1   |  |
| Baud-Rate              | COM3 (230.4 kBaud)   |  |
| Conforms to            | IO-Link Interface and System Specification, V1.1.5, October 2025 |  |
| Device ID              | 0x00001B   |  |
| Vendor ID              | 1093   | Hex: 04 45   |
| Supported profiles     | identification and diagnosis                                     |  |
| Cycle Time             | 5 ms   | cycle time refers to the reloading speed of certain process data |
| SIO-Mode               | yes  | Class A  |
| Process data length    | 13 bytes   |  |
| Block parameterisation | yes  |  |
| Data storage           | yes  |  |

The power supply provides three categories of data via IO-Link. They are divided between read only or read- and customisable data.

### Process Data

Continuous access to real-time operating data provides full transparency of the power supply’s performance. Key values such as voltage, current, and device status are available directly in the control system, enabling optimized process control and maximum system availability.

### Parameter Values

Flexible, software-based parameterization allows fast and easy configuration without manual adjustment. Central storage of parameters in the controller ensures quick, error-free device replacement and significantly reduces commissioning and service time.

### Events

Intelligent diagnostic and event messaging delivers early warnings and detailed fault information. This enables rapid troubleshooting, minimizes unplanned downtime, and supports predictive maintenance strategies for increased operational efficiency.

### Available Process, Diagnostic and Service Data:

- Device status and diagnostics: Operating states, events and diagnostic information
- Operating data: Lifetime info and switching cycles
- Thermal diagnostics: Device temperature monitoring with warning limits
- Remote control: Output voltage on/off control via IO-Link
- IO-Link interface status: IO-Link supply and communication voltage monitoring

## 10. Efficiency and Power Losses

|                                  |      | AC 100 V | AC 120 V | AC 230 V |   |
|----------------------------------|------|----------|----------|----------|---|
| Efficiency                       | typ. | 93.2 %   | 93.9 %   | 95.1 %   | at 24 V, 2x 94 W  |
| Average efficiency <sup>1)</sup> | typ. | 92.5 %   | 93.0 %   | 94.1 %   | 25 % at 2x 25 W, 25 % at 2x 50 W,<br>25 % at 2x 75 W, 25 % at 2x 94 W |
| Power losses                     | typ. | 2.7 W    | 2.7 W    | 2.7 W    | at 24 V, 0 W  |
|                                  | typ. | 7.9 W    | 7.5 W    | 6.2 W    | at 24 V, 2x 50 W  |
|                                  | typ. | 13.9 W   | 12.5 W   | 10 W     | at 24 V, 2x 94 W  |

1) The average efficiency is an assumption for a typical application where the power supply is loaded with 25 % of the nominal load for 25 % of the time, 50 % of the nominal load for another 25 % of the time, 75 % of the nominal load for another 25 % of the time and with 100 % of the nominal load for the rest of the time.

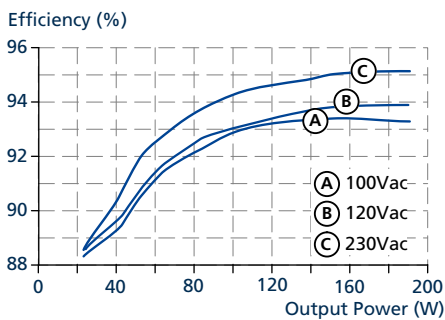

Fig. 10-1: Efficiency vs. output power at 24 V, typ.

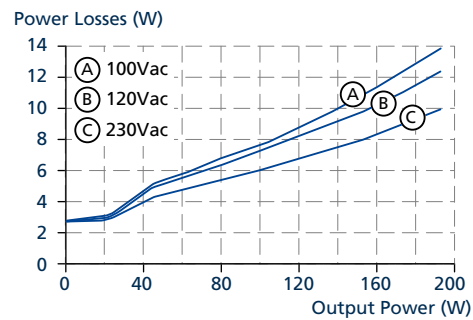

Fig. 10-2: Losses vs. output power at 24 V, typ.

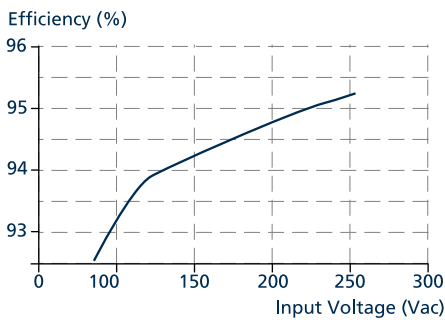

Fig. 10-3: Efficiency vs. input voltage at 24 V, 188 W, typ.

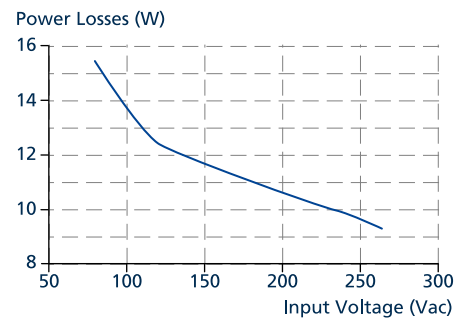

Fig. 10-4: Losses vs. input voltage at 24 V, 188 W, typ.

## 11. Lifetime Expectancy

The lifetime expectancy shown in the table indicates the minimum operating hours (service lifetime) and is determined by the lifetime expectancy of the built-in electrolytic capacitors. Lifetime expectancy is specified in operational hours and is calculated according to the capacitor’s manufacturer specification. The manufacturer of the electrolytic capacitors only guarantees a maximum lifetime of up to 15 years (131 400 h). Any number exceeding this value is a calculated theoretical lifetime, which can be used to compare devices.

|                                | AC 100 V  | AC 120 V  | AC 230 V  |                             |
|--------------------------------|-----------|-----------|-----------|-----------------------------|
| Calculated lifetime expectancy | 130 400 h | 142 100 h | 206 000 h | at 24 V, 2x 94 W and +25 °C |
|                                | 609 200 h | 625 900 h | 714 500 h | at 24 V, 2x 50 W and +25 °C |

## 12. MTBF

MTBF stands for **Mean Time Between Failures**, which is calculated according to statistical device failures, and indicates reliability of a device. It is the statistical representation of the likelihood of a unit to fail and does not necessarily represent the lifetime of a product.

An MTBF figure of e.g. 1 000 000 h means that statistically one unit out of 10 000 installed units will fail every 100 h. However, it can not be determined if the failed unit has been running for 50 000 h or only for 100 h.

For these types of units the MTTF (**Mean Time To Failures**) value is the same value as the MTBF value.

|                          | AC 100 V  | AC 120 V  | AC 230 V  |  |
|--------------------------|-----------|-----------|-----------|--|
| MTBF SN 29500, IEC 61709 | 544 000 h | 636 000 h | 784 000 h | at 24 V, 2x 94 W and +25 °C                        |
| MTBF MIL HDBK 217F       | 203 000 h | 228 000 h | 266 000 h | at 24 V, 2x 94 W and +25 °C;<br>Ground Benign GB25 |
|                          | 55 000 h  | 61 000 h  | 70 000 h  | at 24 V, 2x 94 W and +25 °C;<br>Ground Fixed GF25  |

### 13. Functional Diagram

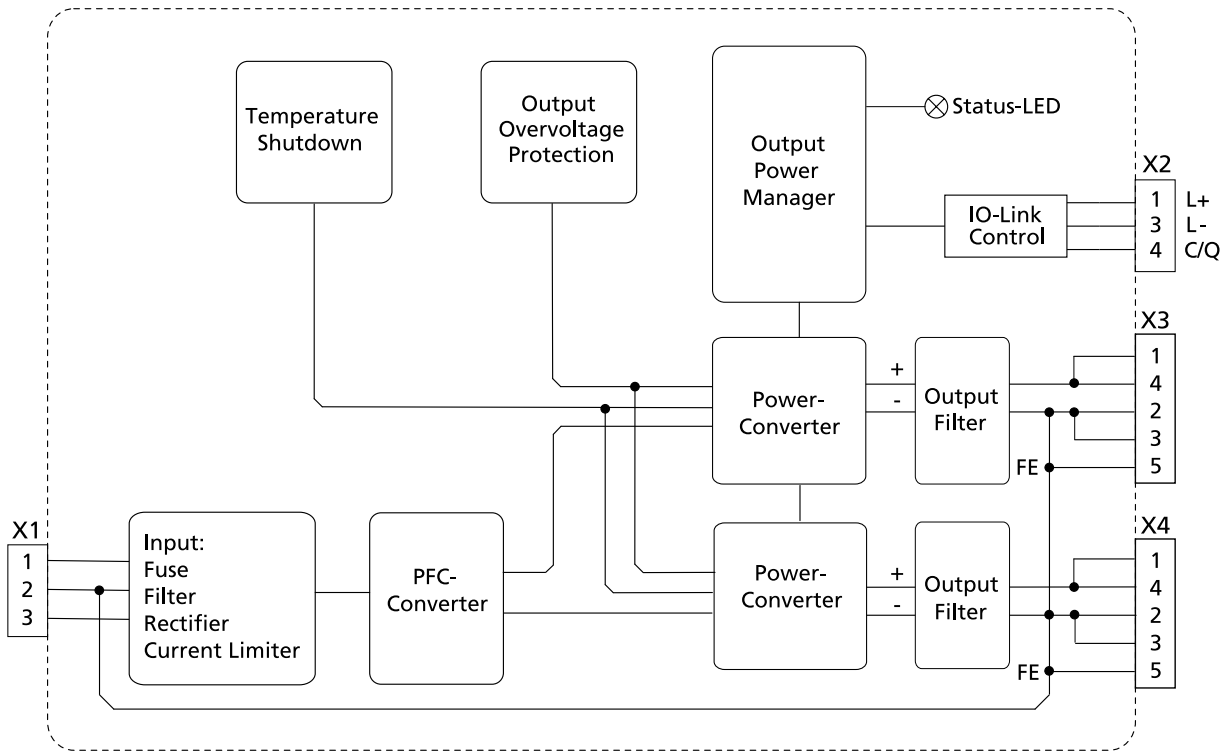
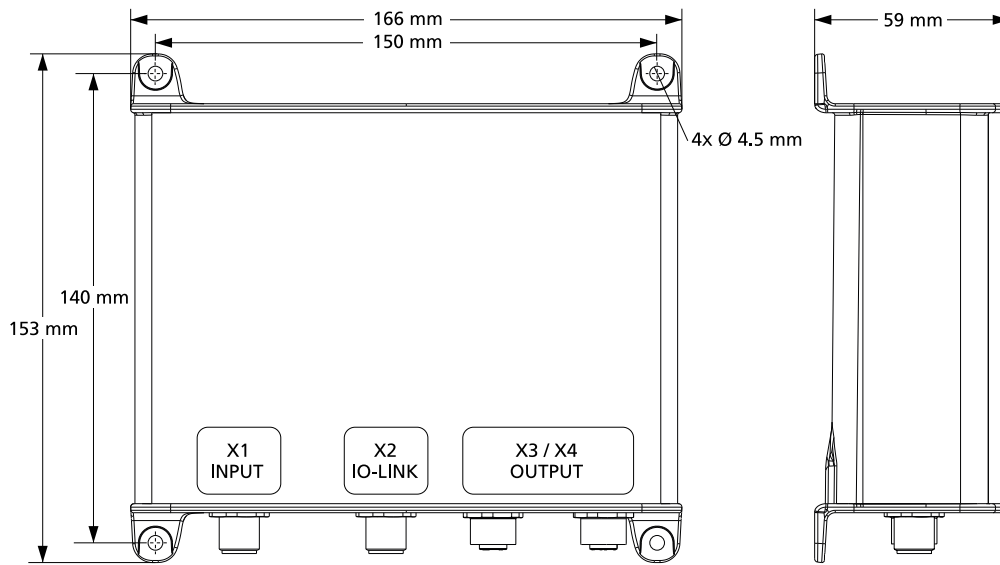

Fig. 13-1: Functional Diagram FPS202.242-004-IOL

## 14. Dimensions and Connectors



Width: 166 mm  
 Height: 153 mm  
 Depth: 59 mm  
 Weight: 790 g

Housing body material: Hi-grade polycarbonate  
 Housing cover material: Hi-grade polycarbonate  
 Installation clearances: 50 mm on top, 10 mm on the left and right side

**NOTE**

Ensure adequate clearance below the device for mating connectors and cables.

**Input connector on power supply (X1):**



M12-S 3pin male

Pin 1: L  
 Pin 2: PE connection  $\oplus$   
 Pin 3: N

**IO-Link connector on power supply (X2):**

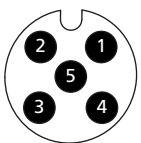

M12-A 5pin male

Pin 1: L+  
 Pin 2: Not connected  
 Pin 3: L-  
 Pin 4: C/Q  
 Pin 5: Not connected

**Output connector on power supply (X3, X4):**

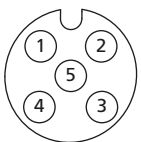

M12-A 5pin female

Pin 1: 24 Vdc  
 Pin 2: GND  
 Pin 3: GND  
 Pin 4: 24 Vdc  
 Pin 5: FE connection  $\oplus$



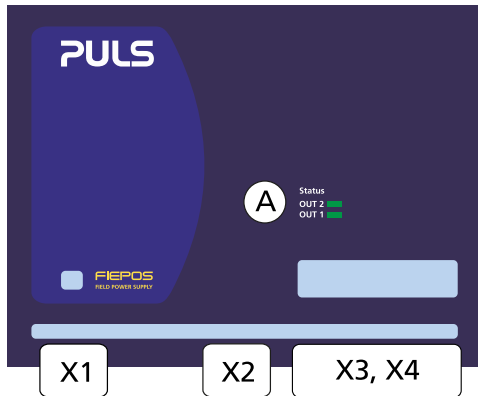



## 15. User Interface



|        |                   |
|--------|-------------------|
| X1     | Input connector   |
| X2     | IO-Link connector |
| X3, X4 | Output connector  |
| A      | Status LED        |

### LED signaling

The Status LED (A) displays different running conditions of the device in real-time.

- 
**Off**  
 The output is switched off or the power supply is not powered.
- 
**Green: Output On**  
 The output is switched on, current is below warning threshold of 80%.
- 
**Flashes green slow (500 ms ON/OFF): Output Off**  
 The output is switched off via IO-Link.
- 
**Orange: Pre-Alarm**  
 Output is switched on, but current is above overcurrent warning threshold of 80%.
- 
**Flashes orange slow (500 ms ON/OFF): Output is tripped because of overload**  
 The output is tripped. The reason may be one of the following:
  - The output current exceeded the set trip value
  - The output exceeded the internal temperature limit because of overload and/or ambient temperature
 The output automatically turns on after 18 s or cooling-off.
- 
**Flashes orange fast (125 ms ON/OFF): Output is tripped because of short circuit**  
 The output is tripped. The reason may be one of the following:
  - Electrical short
  - Plugging-in a large capacitance during operation circuit
 The output automatically turns on after 18 s or cooling-off.
- 
**Red: Hardware fault**  
 Fatal hardware fault, hardware circuit damaged.

## 16. EMC

The EMC behaviour of the device is designed for applications in industrial environment as well as in residential, commercial and light industry environments.

The device is investigated according to EN 61000-6-1, EN 61000-6-2, EN 61000-6-3, EN 61000-6-4, EN 61000-3-2 and EN 61000-3-3.

### EMC Immunity\*

|                            |               |  |                  |             |
|----------------------------|---------------|--|------------------|-------------|
| Electrostatic discharge    | EN 61000-4-2  | contact discharge  | 8 kV             | Criterion A |
| Air discharge              |               | air discharge  | 15 kV            | Criterion A |
| Electromagnetic RF field   | EN 61000-4-3  | 80 MHz - 1 GHz   | 20 V/m           | Criterion A |
|                            |               | 1 GHz - 6 GHz  | 10 V/m           | Criterion A |
| Fast transients (Burst)    | EN 61000-4-4  | AC input lines   | 4 kV             | Criterion A |
|                            |               | DC output lines  | 2 kV             | Criterion A |
|                            |               | IO-Link  | 2 kV             | Criterion A |
| Surge voltage on AC input  | EN 61000-4-5  | L → N  | 2 kV             | Criterion A |
|                            |               | L / N → PE   | 4 kV             | Criterion A |
| Surge voltage on DC output | EN 61000-4-5  | (+) → (-)  | 1 kV             | Criterion A |
|                            |               | (+) / (-) → PE   | 2 kV             | Criterion A |
| Surge voltage on IO-Link   | EN 61000-4-5  | IO-Link → PE   | 1 kV             | Criterion A |
| Conducted immunity         | EN 61000-4-6  | AC input   | 20 V             | Criterion A |
|                            |               | DC output  | 20 V             | Criterion A |
|                            |               | IO-Link  | 10 V             | Criterion A |
| Voltage dips               | EN 61000-4-11 | 0 % of 100 Vac   | 0 Vac, 20 ms     | Criterion A |
|                            |               | 40 % of 100 Vac  | 40 Vac, 200 ms   | Criterion C |
|                            |               | 70 % of 100 Vac  | 70 Vac, 500 ms   | Criterion C |
|                            | EN 61000-4-11 | 0 % of 200 Vac   | 0 Vac, 20 ms     | Criterion A |
|                            |               | 40 % of 200 Vac  | 80 Vac, 200 ms   | Criterion A |
|                            |               | 70 % of 200 Vac  | 140 Vac, 500 ms  | Criterion A |
| Voltage interruptions      | EN 61000-4-11 | 0 % of 200 Vac   | 0 Vac, 5000 ms   | Criterion C |
| Voltage sags               | SEMI F47      | dips on the input voltage according to SEMI F47 standard |                  |             |
|                            |               | 80 % of 208 Vac  | 166 Vac, 1000 ms | Criterion A |
|                            |               | 70 % of 208 Vac  | 145 Vac, 500 ms  | Criterion A |
|                            |               | 50 % of 208 Vac  | 104 Vac, 200 ms  | Criterion A |
| Powerful transients        | VDE 0160      | over entire load range                                   | 750 V, 0.3 ms    | Criterion A |

### Performance criterions:

**A:** The device shows normal operation behavior within the defined limits.

**C:** Temporary loss of function is possible. The device may shut down and restart by itself. No damage or hazards for the device will occur.

\*Levels according to EN 61326-1:2013-01 for IO-Link certification immunity have been tested.

### EMC Emission

|                                    |                                      |  |
|------------------------------------|--------------------------------------|--|
| Conducted emission AC input lines  | EN IEC 61000-6-3, EN 55032, EN 55011 | Class B  |
| Conducted emission DC output lines | EN IEC 61000-6-3                     |  |
| Radiated emission                  | EN IEC 61000-6-3, EN 55032, EN 55011 | Class B  |
| Harmonics                          | EN 61000-3-2                         | pass for Class A equipment                           |
| Voltage fluctuations, flicker      | EN 61000-3-3                         | pass tested with constant current loads, non pulsing |

This device complies with FCC Part 15 rules.

Operation is subjected to following two conditions: (1) this device may not cause harmful interference, and (2) this device must accept any interference received, including interference that may cause undesired operation.

**Switching Frequencies**

|                        |                   |   |
|------------------------|-------------------|---|
| PFC converter          | 20 kHz to 135 kHz | input voltage and output load dependent |
| Main converter         | 60 kHz to 140 kHz | output load dependent                   |
| Auxiliary converter    | 54 kHz to 66 kHz  | output load dependent                   |
| Microcontroller clocks | 48 MHz and 32 MHz | fixed frequency                         |

## 17. Environment

|                         |  |   |
|-------------------------|--|---|
| Operational temperature | -30 °C to +70 °C   | Operational temperature is the same as the ambient or surrounding temperature and is defined as the air temperature 3 cm below the unit.  |
| Storage temperature     | -40 °C to +85 °C   | for storage and transportation  |
| Output derating         | 2.8 W / °C<br>20 W / 1000 m or 5 °C / 1000 m for altitudes > 2000 m, see Fig. 17-2<br>The derating is not hardware controlled. The application has to stay below the derated current limits in order not to overload the unit. | between +45 °C and +70 °C, see Fig. 17-1  |
| Humidity                | 5-95 % r.h.  | according to IEC 60068-2-30   |
| Atmospheric pressure    | 54-110 kPa   | see Fig. 17-2   |
| Altitude                | up to 5000 m   | see Fig. 17-2   |
| Overvoltage category    | III  | according to IEC 60664-1<br>for TN-, TT-mains systems with earthed neutral and IT star mains systems with insulation monitoring for altitudes up to 2000 m  |
|                         | II   | according to IEC 60664-1<br>for TN-, TT-mains systems with earthed neutral and IT star mains systems with insulation monitoring for altitudes between 2000 m and 5000 m<br>according to IEC 60664-1<br>for TN-, TT-, IT-delta mains systems or IT star mains systems without insulation monitoring for altitudes up to 2000 m |
| Degree of pollution     | 2  | according to IEC/UL 61010-1   |
| Vibration sinusoidal    | 2-17.8 Hz: ±1.6 mm;<br>17.8-500 Hz: 2 g<br>2 hours / axis  | according to IEC 60068-2-6  |
| Shock                   | 30 g 6 ms, 20 g 11 ms<br>3 bumps / direction, 18 bumps in total  | according to IEC 60068-2-27   |
| Audible noise           | Some audible noise may be emitted from the power supply during no load, overload or short-circuit.   |   |

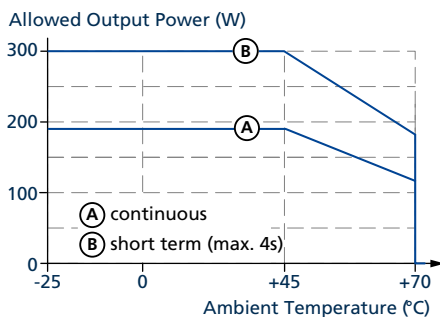

Fig. 17-1: Output power vs. ambient temp.

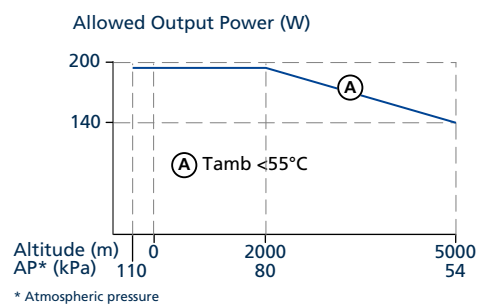

Fig. 17-2: Output power vs. altitude

## 18. Safety and Protection Features

|                               |      |                            |   |
|-------------------------------|------|----------------------------|---|
| Isolation resistance          | min. | 500 MOhm                   | at delivered condition between input and output, measured with 500 Vdc  |
|                               | min. | 500 MOhm                   | at delivered condition between input and PE, measured with 500 Vdc  |
| PE resistance                 | max. | 0.1 Ohm                    | resistance between PE terminal and housing  |
| Input / Output separation     |      | PELV/ES1                   | IEC/EN/UL 61010-2-201, IEC/EN 62368-1, IEC/EN 60950-1   |
| Output overvoltage protection | typ. | 31.8 Vdc                   |   |
|                               | max. | 32.5 Vdc                   | In case of an internal defect, a redundant circuit limits the maximum output voltage. The output shuts down and automatically attempts to restart.  |
| Class of protection           |      | I                          | according to IEC 61140<br>a PE (Protective Earth) connection is required  |
| Degree of protection          |      | IP65 and IP67              | according to EN/IEC 60529   |
| Overtemperature protection    |      | included                   | Output shut down with automatic restart. Temperature sensors are installed on critical components inside the unit and the unit turns off in safety critical situations, which can happen, e.g. when ambient temperature is too high, ventilation is obstructed or the derating requirements are not followed. There is no correlation between the operating temperature and turn-off temperature since this is dependent on input voltage, load and installation methods. |
| Input transient protection    |      | MOV (Metal Oxide Varistor) | for protection values, see chapter 16.  |
| Internal input fuse           |      | included                   | not user replaceable slow-blow high-breaking capacity fuse, 6.3 A (T)   |
| PE conductor current          | max. | 0.49 mA <sub>rms</sub>     | at 264 Vac, 60 Hz, TN-,TT-mains / IT-mains  |

## 19. Dielectric Strength

The negative terminals of the outputs are permanently connected to PE within the unit. The output is separated from the input by a double or reinforced insulation.

Type and routine tests are conducted by the manufacturer. Field tests may be conducted in the field using the appropriate test equipment which applies the voltage with a slow ramp (2 s up and 2 s down). Connect all input terminals before conducting the test. When testing, set the cut-off current settings to the value in the table below.

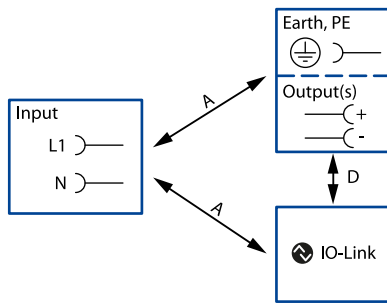







Fig. 19-1: Dielectric strength

|  |      | A        | D       |
|--|------|----------|---------|
| Type test                              | 60 s | 2500 Vac | 500 Vac |
| Routine test                           | 5 s  | 2500 Vac | 500 Vac |
| Field test                             | 5 s  | 2000 Vac | 500 Vac |
| Cut-off current setting for field test |      | > 10 mA  | > 10 mA |

## 20. Approved, Fulfilled or Tested Standards

|             |   |   |
|-------------|---|---|
| IEC 62368   | <b>CB Report</b>  | CB Scheme Certificate<br>IEC 62368-1 - Audio / video, information and communication technology equipment - Safety requirements<br>Output safety level: ES1  |
| IEC 61010   | <b>CB Report</b>  | CB Scheme Certificate<br>IEC 61010-2-201 - Electrical Equipment for Measurement, Control and Laboratory Use - Particular requirements for control equipment   |
| IEC 60950   | <b>Safety</b> ✓   | Manufacturers Declaration<br>IEC 60950-1 – General safety requirements for Information Technology Equipment (ITE)   |
| UL 61010    |  | UL Certificate<br>Listed equipment for category NMTR - UL 61010-2-201 - Electrical equipment for measurement, control and laboratory use - Particular requirements for control equipment<br>Applicable for US and Canada<br>E-File: E198865 |
| NEC Class 2 | <b>NEC CLASS 2</b>  | UL Certificate<br>Limited Power Source<br>Listed in the UL 61010-2-201 approval report, investigated according to UL 1310   |
| Semi F47    | <b>SEMI F47</b>   | Test Report<br>Voltage Sag Immunity for Semiconductor Processing Equipment<br>Tested for AC 208 V L-L or L-N mains voltages, nominal output voltage and nominal output load   |
| VDMA 24364  | <b>LABS</b><br>VDMA 24364-C1-L/W  | Paint Wetting Impairment Substances Test (or LABS-Test)<br>Tested for Zone 2 and Test Class C1 according to VDMA 24364-C1-L/W for solvents and water-based paints   |

## 21. Regulatory Product Compliance

|                              |   |  |
|------------------------------|---|--|
| EU Declaration of Conformity |  | <p>The CE mark indicates conformance with the European</p> <ul style="list-style-type: none"> <li>- EMC directive</li> <li>- Low-voltage directive (LVD)</li> <li>- RoHS directive</li> </ul>          |
| WEEE Directive               |  | <p>Manufacturer's Declaration<br/>EU-Directive on Waste Electrical and Electronic Equipment (WEEE)<br/>registered in Germany as business to business (B2B) products.<br/>WEEE-Reg.-Nr. DE 55837529</p> |
| REACH Regulation (EU)        |  | <p>Manufacturer's Statement<br/>EU regulation regarding the Registration, Evaluation, Authorisation and Restriction of Chemicals (REACH) fulfilled.</p>  |
| RoHS-China                   |  | <p>Manufacturer's Statement<br/>Administrative Measures for the Restriction of the Use of Hazardous Substances in Electrical and Electronic Products 25 years</p>                                      |
| IEC/EN 61558-2-16 (Annex BB) | Safety Isolating Transformer  | Safety Isolating Transformers corresponding to Part 2-6 of the IEC/EN 61558  |

## 22. Application Notes

---

### 22.1. Repetitive Pulse Loading

Typically, a load current is not constant and varies over time. This power supply is designed to support loads with a higher short-term power demand. The short-term duration is hardware controlled by an output power manager and is available on a repeated basis. If the average load is higher than the rated output power, the output voltage will dip.

To avoid this, the following rules must be followed:

- a) The power demand of the pulse must be below 200 % of the nominal output power.
- b) The duration of the pulse power must be shorter than the allowed short-term power time, see chapter 7.
- c) The average power should be lower than the nominal output power.

The R.M.S. output current must be below the specified continuous output current. If the R.M.S. current is higher, the unit may respond with a thermal shut-down after a period of time.

### 22.2. External Input Protection

The device is designed, tested and approved for branch circuits up to 32 A (UL) and 32 A (IEC) without an additional protection device. If an external device (fuse or circuit breaker) is utilized, do not use fuses or circuit breaker smaller than 6 A (type B- or C-characteristic) to avoid an unintentional tripping.

### 22.3. Inductive and Capacitive Loads

The power supply is designed to supply any kind of loads, including capacitive and inductive loads. If extreme large capacitors, such as EDLCs (electric double layer capacitors or "UltraCaps") with a capacitance larger than 100 mF are connected to the output, the power supply might charge the capacitor or the output might trip, see chapter 7.

### 22.4. Back-Feeding Loads

Loads such as decelerating motors and inductors can feed voltage back to the power supply. This feature is also called return voltage immunity or resistance against Back-E.M.F. (Electro **M**agnetic **F**orce).

This power supply is resistant and does not show malfunctioning when a load feeds back voltage to the power supply below 35 V / 0.5 J. It does not matter whether the power supply is on or off.

### 22.5. Parallel Use to Increase Output Power

Do not use parallel outputs or devices for higher output currents.

### 22.6. Series Operation

Do not connect power supplies in series.

## 22.7. Mounting Orientations

The device can be panel mounted in various mounting orientations. The listed lifetime and MTBF values from this datasheet apply only for the standard mounting orientation. The following curves give an indication for allowed output power in different mounting orientations for altitudes up to 2000 m.

**A**  
Standard orientation

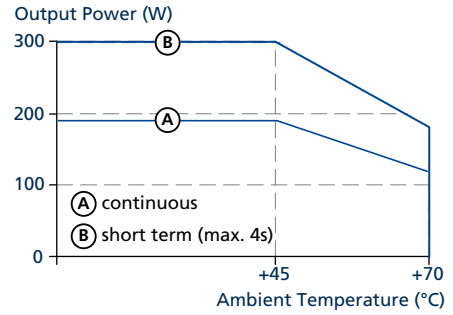
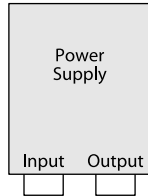

**B**  
Upside down

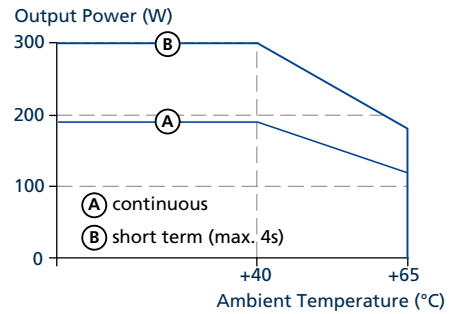
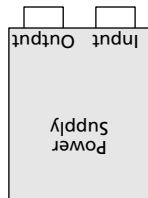

**C**  
Horizontal clockwise  
and counter clockwise

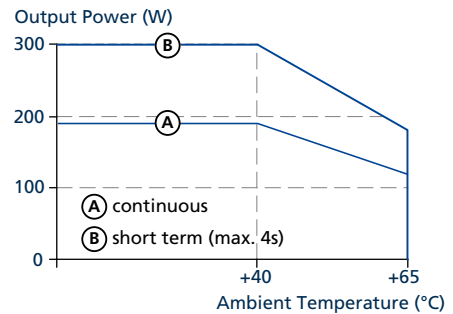

**D**  
Overhead and tabletop  
mounting

