



## POWER SUPPLY

- AC 100-240V Wide-range Input
- Width only 32mm
- Efficiency up to 94.0%
- Excellent Partial Load Efficiency
- 20% Output Power Reserves (PowerBoost)
- Easy Fuse Breaking – 3 times nominal current for 12ms
- Safe Hiccup<sup>PLUS</sup> Overload Mode
- Active Power Factor Correction (PFC)
- Minimal Inrush Current Surge
- Full Power Between -25°C and +60°C
- DC-OK Relay Contact
- 3 Year Warranty

## PRODUCT DESCRIPTION

The Dimension CP-Series are cost optimized power supplies without compromising quality, reliability and performance. The CP-Series is part of the DIMENSION power supply family.

The most outstanding features of this unit is the small size, the high efficiency, the electronic inrush current limitation, active PFC and the wide operational temperature range. The devices also offer PowerBoost: Power reserves of 20%, which may even be used continuously at temperatures up to +45°C. Additionally, it can deliver 3 times the nominal output current for 12ms which helps to trip fuses on faulty output branches.

High immunity to transients and power surges as well as low electromagnetic emission, a DC-OK signal contact for remote monitoring, and a large international approval package for a variety of applications makes this unit suitable for nearly every situation.

## SHORT-FORM DATA

Output voltage	DC 12V	Nominal
Adjustment range	12 - 15V	Factory setting 12.0V
Output current	10.0 – 8.0A	Up to +60°C ambient
	7.5 – 6.0A	At +70°C ambient
	Derate linearly between +60°C and +70°C	
PowerBoost	12A	Up to +45°C ambient
	Linear decrease to nominal power between +45°C and +60°C	
Input voltage AC	AC 100-240V	-15%/+10%
Mains frequency	50-60Hz	±6%
Input current AC	1.09 / 0.6A	At 120 / 230Vac
Power factor	0.98 / 0.91	At 120 / 230Vac
Input voltage DC	DC 110-150V	±20%
Input current DC	1.21A	At 110 / 300Vdc
AC Inrush current	5/ 6 Apeak	At 120 / 230Vac
Efficiency	93.2 / 94.0%	At 120 / 230Vac
Losses	8.8 / 7.7W	At 120 / 230Vac
Hold-up time	35 / 35ms	At 120 / 230Vac
Temperature range	-25°C to +70°C	
Size (WxHxD)	32x124x102mm	Without DIN rail
Weight	440g	

## ORDER NUMBERS

Power Supply	<b>CP5.121</b>
Accessory	ZM10.WALL Wall/Panel mount bracket

## MAIN APPROVALS

For details and the complete approval list, see chapter 19.



UL 610101-2-201



ATEX



IECEX



Class I Div 2

**INDEX**



	Page		Page
1. Intended Use .....	3	18. Dielectric Strength.....	19
2. Installation Instructions .....	3	19. Approved, Fulfilled or Tested Standards.....	20
3. AC-Input.....	5	20. Regulatory Product Compliance .....	21
4. DC-Input.....	7	21. Physical Dimensions and Weight.....	22
5. Input Inrush Current .....	8	22. Accessories .....	23
6. Output .....	9	22.1. ZM10.WALL - Wall/Panel Mount Bracket	23
7. Hold-up Time.....	11	22.2. YR20.242 - Redundancy Module.....	24
8. DC-OK Relay Contact .....	11	23. Application Notes.....	25
9. Efficiency and Power Losses.....	12	23.1. Peak Current Capability .....	25
10. Functional Diagram.....	13	23.2. Charging of Batteries .....	26
11. Front Side and User Elements.....	13	23.3. Series Operation .....	26
12. Terminals and Wiring.....	14	23.4. Parallel Use to Increase Output Power....	26
13. Lifetime Expectancy .....	15	23.5. Parallel Use for Redundancy .....	27
14. MTBF .....	15	23.6. Operation on Two Phases .....	28
15. EMC.....	16	23.7. Use in a Tightly Sealed Enclosure .....	28
16. Environment .....	17	23.8. Mounting Orientations .....	29
17. Safety and Protection Features .....	18		

The information given in this document is correct to the best of our knowledge and experience at the time of publication. If not expressly agreed otherwise, this information does not represent a warranty in the legal sense of the word. As the state of our knowledge and experience is constantly changing, the information in this data sheet is subject to revision. We therefore kindly ask you to always use the latest issue of this document (available under [www.pulspower.com](http://www.pulspower.com)).

No part of this document may be reproduced or utilized in any form without our prior permission in writing.

Packaging and packaging aids can and should always be recycled. The product itself may not be disposed of as domestic refuse.

**TERMINOLOGY AND ABBREVIATIONS**

<b>PE and  symbol</b>	PE is the abbreviation for <b>Protective Earth</b> and has the same meaning as the symbol  .
<b>Earth, Ground</b>	This document uses the term "earth" which is the same as the U.S. term "ground".
<b>t.b.d.</b>	To be defined, value or description will follow later.
<b>AC 230V</b>	A figure displayed with the AC or DC before the value represents a nominal voltage with standard tolerances (usually $\pm 15\%$ ) included. E.g.: DC 12V describes a 12V battery disregarding whether it is full (13.7V) or flat (10V)
<b>230Vac</b>	A figure with the unit (Vac) at the end is a momentary figure without any additional tolerances included.
<b>50Hz vs. 60Hz</b>	As long as not otherwise stated, AC 230V parameters are valid at 50Hz mains frequency.
<b>may</b>	A key word indicating flexibility of choice with no implied preference.
<b>shall</b>	A key word indicating a mandatory requirement.
<b>should</b>	A key word indicating flexibility of choice with a strongly preferred implementation.

## 1. INTENDED USE

This device is designed for installation in an enclosure and is intended for commercial use, such as in industrial control, process control, monitoring, measurement, Audio/Video, information or communication equipment or the like.

Do not use this device in equipment, where malfunctioning may cause severe personal injury or threaten human life without additional appropriate safety devices, that are suited for the end-application.

If this device is used in a manner outside of its specification, the protection provided by the device may be impaired.

## 2. INSTALLATION INSTRUCTIONS

### **⚠ WARNING** Risk of electrical shock, fire, personal injury or death.

- Turn power off before working on the device and protect against inadvertent re-powering.
- Do not open, modify or repair the device.
- Use caution to prevent any foreign objects from entering into the housing.
- Do not use in wet locations or in areas where moisture or condensation can be expected.
- Do not touch during power-on, and immediately after power-off. Hot surface may cause burns.

### **Obey the following installation instructions:**

This device may only be installed and put into operation by qualified personnel.

This device does not contain serviceable parts. The tripping of an internal fuse is caused by an internal defect.

If damage or malfunction should occur during installation or operation, immediately turn power off and send unit to the factory for inspection.

Install device in an enclosure providing protection against electrical, mechanical and fire hazards.

Install the device onto a DIN rail according to EN 60715 with the input terminals on the bottom and the output terminals on the top of the device. Other mounting orientations require a reduction in output current.

Make sure that the wiring is correct by following all local and national codes. Use appropriate copper cables that are designed for a minimum operating temperature of 60°C for ambient temperatures up to +45°C, 75°C for ambient temperatures up to +60°C and 90°C for ambient temperatures up to +70°C.

Ensure that all strands of a stranded wire enter the terminal connection. Use ferrules for wires on the input terminals. Unused screw terminals should be securely tightened.

The device is designed for pollution degree 2 areas in controlled environments. No condensation or frost is allowed.

The enclosure of the device provides a degree of protection of IP20. The housing does not provide protection against spilled liquids.

The isolation of the device is designed to withstand impulse voltages of overvoltage category III according to IEC 60664-1.

The device is designed as "Class of Protection I" equipment according to IEC 61140. Do not use without a proper PE (Protective Earth) connection.

The device is suitable to be supplied from TN, TT or IT mains networks. The continuous voltage between the input terminal and the PE potential must not exceed 300Vac.

The input can also be powered from batteries or similar DC sources. The continuous voltage between the supply voltage and the PE/ground potential must not exceed 360Vdc.

A disconnecting means shall be provided for the input of the device.

The device is designed for convection cooling and does not require an external fan. Do not obstruct airflow and do not cover ventilation grid!

The device is designed for altitudes up to 5000m. Above 2000m a reduction in output current and over voltage category is required.

Keep the following minimum installation clearances: 40mm on top, 20mm on the bottom, 5mm left and right side. Increase the 5mm to 15mm in case the adjacent device is a heat source. When the device is permanently loaded with less than 50%, the 5mm can be reduced to zero.

The device is designed, tested and approved for branch circuits up to 32A (IEC) and 30A (UL) without additional protection device. If an external fuse is utilized, do not use circuit breakers smaller than 6A B- or C-Characteristic to avoid a nuisance tripping of the circuit breaker.

The maximum surrounding air temperature is +70°C. The operational temperature is the same as the ambient or surrounding air temperature and is defined 2cm below the device.

The device is designed to operate in areas between 5% and 95% relative humidity.

### Installation Instructions for Hazardous Location Areas

The device is suitable for use in Class I Division 2 Groups A, B, C, D locations and for use in Group II Category 3 (Zone 2) environments.

Classification: ATEX: EPS 19 ATEX 1 201 X, II 3G Ex ec nC IIC T4 Gc / IECEx EPS 19.0078X

#### **WARNING** EXPLOSION HAZARDS!

Installation in standard mounting orientation with the input terminals on the bottom of the unit. For non-standard mounting orientations a reduction of output current is required.

Do not disconnect the device or operate the voltage adjustment unless power has been switched off or the area is known to be non-hazardous.

A suitable enclosure must be provided for the end product which has a minimum protection of IP54 and fulfils the requirements of the EN 60079-0.

### 3. AC-INPUT

The device is suitable to be supplied from TN, TT or IT mains networks with AC voltage. For suitable DC supply voltages see chapter 4.

AC input	Nom.	AC 100-240V	
AC input range		85-264Vac	
		264-300Vac	Occasionally for maximal 500ms
Allowed voltage L or N to earth	Max.	300Vac	Continuous, according to IEC 60664-1
Input frequency	Nom.	50–60Hz	±6%
Turn-on voltage	Typ.	80Vac	Steady-state value, see Fig. 3-1
Shut-down voltage	Typ.	74Vac	Steady-state value, see Fig. 3-1
External input protection		See recommendations in chapter 2.	

		<b>AC 100V</b>	<b>AC 120V</b>	<b>AC 230V</b>	
Input current	Typ.	1.30A	1.09A	0.60A	At 12V, 10A, see Fig. 3-3
Power factor	Typ.	0.99	0.98	0.91	At 12V, 10A, see Fig. 3-4
Crest factor	Typ.	1.7	1.8	2.2	At 12V, 10A The crest factor is the mathematical ratio of the peak value to RMS value of the input current waveform.
Start-up delay	Typ.	400ms	350ms	375ms	See Fig. 3-2
Rise time	Typ.	30ms	30ms	30ms	At 12V, 10A const. current load, 0mF load capacitance, see Fig. 3-2
	Typ.	50ms	50ms	50ms	At 12V, 10A const. current load, 10mF load capacitance,, see Fig. 3-2
Turn-on overshoot	Max.	200mV	200mV	200mV	See Fig. 3-2

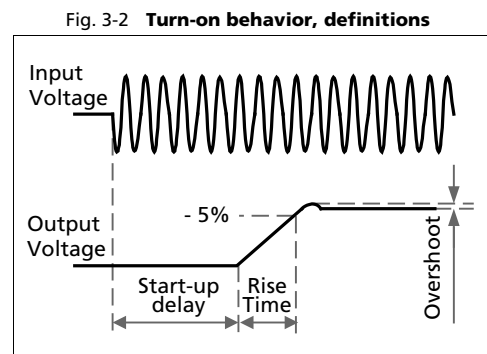
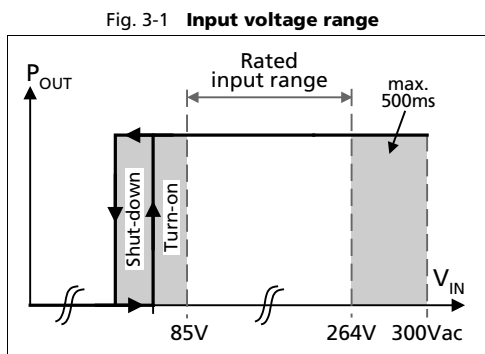

**Fig. 3-3 Input current vs. output current at 12V output voltage**

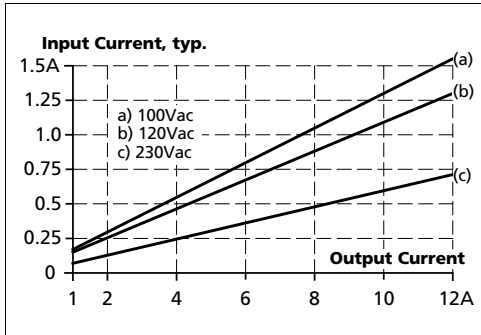

**Fig. 3-4 Power factor vs. output current at 12V output voltage**

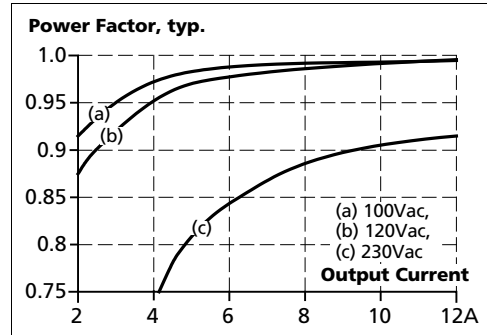

## 4. DC-INPUT

The device is suitable to be supplied from a DC input voltage. Use a battery or a similar DC source. A supply from the intermediate DC-bus of a frequency converter is not recommended and can cause a malfunction or damage the unit. Connect +pole to L, -pole to N and the PE terminal to an earth wire or to the machine ground.

DC input	Nom.	DC 110-150V	±20%
DC input range		88-180Vdc	
DC input current	Typ.	1.21A	At 110Vdc
Allowed Voltage (+) or (-) input to Earth	Max.	180Vdc	Continuous, according to IEC 60664-1,
Turn-on voltage	Typ.	74Vdc	Steady state value
Shut-down voltage	Typ.	67Vdc	Steady state value

Fig. 4-1 **Wiring for DC Input**

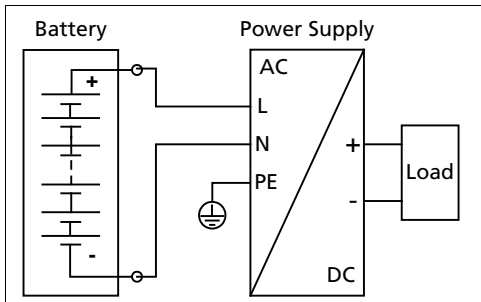

## 5. INPUT INRUSH CURRENT

An active inrush limitation circuit (NTCs, which are bypassed by a relay contact) limits the input inrush current after turn-on of the input voltage.

The charging current into EMI suppression capacitors is disregarded in the first microseconds after switch-on.

		AC 100V	AC 120V	AC 230V	
Inrush current	Max.	8A <sub>peak</sub>	7A <sub>peak</sub>	7A <sub>peak</sub>	At 40°C, cold start
	Typ.	5A <sub>peak</sub>	4A <sub>peak</sub>	4A <sub>peak</sub>	At 25°C, cold start
	Typ.	5A <sub>peak</sub>	5A <sub>peak</sub>	6A <sub>peak</sub>	At 40°C, cold start
Inrush energy	Max.	0.4A <sup>2</sup> s	0.5A <sup>2</sup> s	1A <sup>2</sup> s	At 40°C, cold start

Fig. 5-1 Typical turn-on behaviour at nominal load, 120Vac input and 25°C ambient

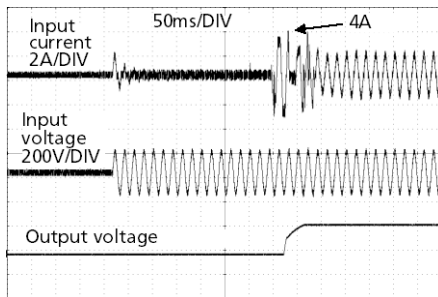
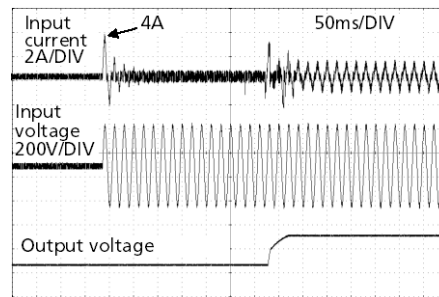

Fig. 5-2 Typical turn-on behaviour at nominal load, 230Vac input and 25°C ambient



## 6. OUTPUT

The output provides a SELV/PELV rated voltage, which is galvanically isolated from the input voltage.

The device is designed to supply any kind of loads, including capacitive and inductive loads. If extreme large capacitors, such as EDLCs (electric double layer capacitors or "UltraCaps") with a capacitance > 0.3F are connected to the output, the unit might charge the capacitor in an intermittent mode.

The output is electronically protected against overload, no-load and short-circuits. In case of a protection event, audible noise may occur.

Output voltage	Nom.	12V	
Adjustment range		12-15V	Guaranteed value
	Max.	16.0V	This is the maximum output voltage which can occur at the clockwise end position of the potentiometer due to tolerances. It is not a guaranteed value which can be achieved.
Factory settings	Typ.	12.0V	±0.2%, at full load and cold unit
Line regulation	Max.	10mV	Between 85 and 300Vac
Load regulation	Max.	50mV	Between 0A and 12A, static value
Ripple and noise voltage	Max.	50mVpp	Load >0.3A, Bandwidth 20Hz to 20MHz, 50Ohm
	Max.	200mVpp	Load <0.3A, Bandwidth 20Hz to 20MHz, 50Ohm
Output current	Nom.	10A	At 12V and up to + 60°C ambient temperature
	Nom.	7.5A	At 12V and +70°C ambient temperature
	Nom.	8.0A	At 15V and up to + 60°C ambient temperature
	Nom.	6.0A	At 15V and +70°C ambient temperature
			Derate linearly between +60°C and +70°C, see chapter 16
PowerBoost <sup>1)</sup>	Nom.	12A	At 12V and up to +45°C ambient temperature
		9.6 A	At 15V and up to +45°C ambient temperature
			PowerBoost decreases linearly to nominal power between +45°C and +60°C, see chapter 16
Fuse breaking current	Typ.	30A	Up to 12ms once every five seconds, see Fig. 6-2. The fuse braking current is an enhanced transient current which helps to trip fuses on faulty output branches. The output voltage stays above 10V.
Overload behaviour		Continuous current	Output voltage > 8Vdc, see Fig. 6-1
		Intermittent current <sup>2)</sup>	Output voltage < 6Vdc, see Fig. 6-1
Overload/ short-circuit current	Max.	14.2A	Continuous current, see Fig. 6-1
	Typ.	15A	Intermittent current peak value for typ. 1s Load impedance 50mOhm, see Fig. 6-3 Discharge current of output capacitors is not included.
	Max.	5A	Intermittent current average value (R.M.S.) Load impedance 50mOhm, see Fig. 6-3
Output capacitance	Typ.	2 700µF	Included inside the power supply
Back-feeding loads	Max.	25V	The unit is resistant and does not show malfunctioning when a load feeds back voltage to the power supply. It does not matter whether the power supply is on or off. The absorbing energy can be calculated according to the built-in large sized output capacitor.

- 1) **PowerBoost:** This power/ current is continuously allowed up to an ambient temperature of +45°C. Above +45°C, do not use this power or current longer than a duty cycle of 10% and/ or not longer than 1 minute every 10 minutes.
- 2) At heavy overloads (when output voltage falls below 7V), the power supply delivers continuous output current for 1s. After this, the output is switched off for approx. 9s before a new start attempt is automatically performed. This cycle is repeated as long as the overload exists. If the overload has been cleared, the device will operate normally. See Fig. 6-3.

Fig. 6-1 Output voltage vs. output current, typ.

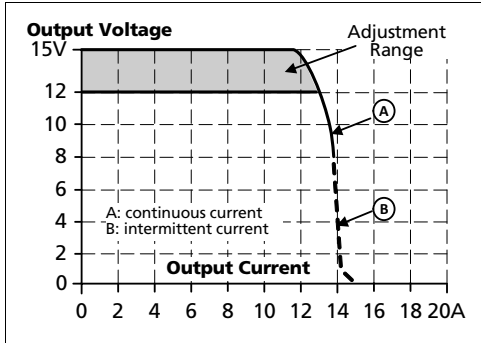

Fig. 6-2 Dynamic output current capability, typ.

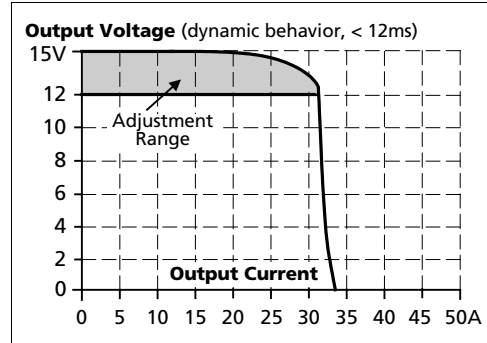
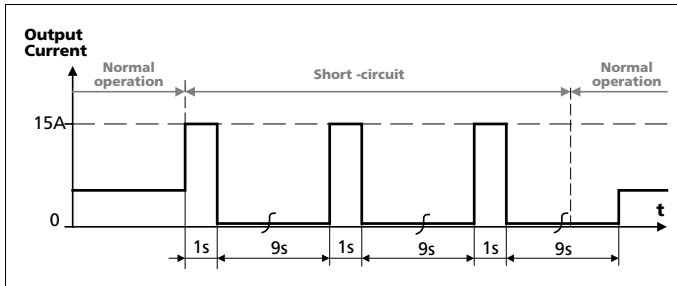

Fig. 6-3 Short-circuit on output, Hiccup<sup>PLUS</sup> mode, typ.



## 7. HOLD-UP TIME

The hold-up time is the time during which a power supply's output voltage remains within specification following the loss of input power. The hold-up time is output load dependent. At no load, the hold-up time can be up to several seconds. The green DC-OK LED is also on during this time.

		<b>AC 100V</b>	<b>AC 120V</b>	<b>AC 230V</b>	
Hold-up Time	Typ.	70ms	70ms	70ms	At 12V, 5A, see Fig. 7-1
	Min.	55ms	55ms	55ms	At 12V, 5A, see Fig. 7-1
	Typ.	35ms	35ms	35ms	At 12V, 10A, see Fig. 7-1
	Min.	27ms	27ms	27ms	At 12V, 10A, see Fig. 7-1

Fig. 7-1 **Hold-up time vs. input voltage**

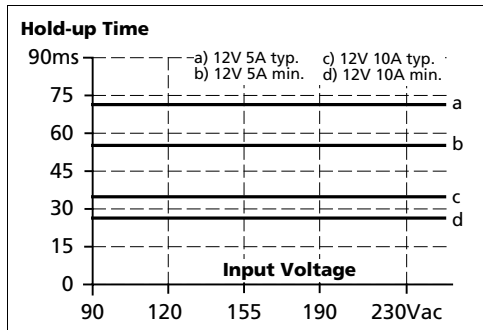
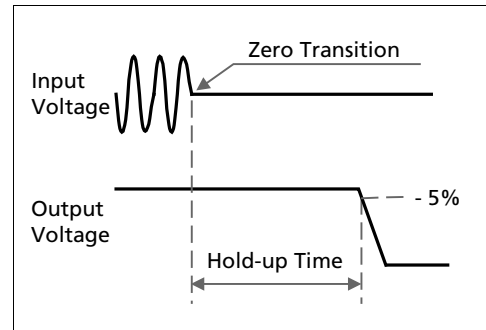

Fig. 7-2 **Shut-down behavior, definitions**



## 8. DC-OK RELAY CONTACT

This feature monitors the output voltage on the output terminals of a running power supply.

Contact closes	As soon as the output voltage reaches typ. 90% of the adjusted output voltage level.
Contact opens	As soon as the output voltage dips more than 10% below the adjusted output voltage. Short dips will be extended to a signal length of 100ms. Dips shorter than 1ms will be ignored.
Switching hysteresis	Typically 0.4V
Contact ratings	Maximal 60Vdc 0.3A, 30Vdc 1A, 30Vac 0.5A, resistive load Minimal permissible load: 1mA at 5Vdc
Isolation voltage	See dielectric strength table in chapter 18.

Fig. 8-1 **DC-OK relay contact behavior**

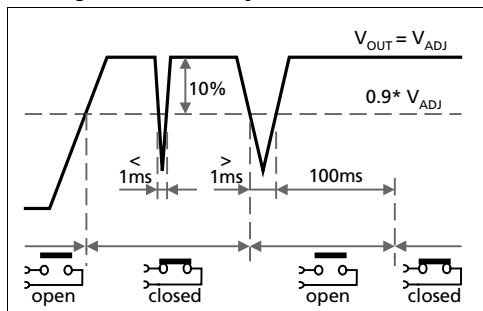

**9. EFFICIENCY AND POWER LOSSES**

		<b>AC 100V</b>	<b>AC 120V</b>	<b>AC 230V</b>	
Efficiency	Typ.	92.6%	93.2%	94.0%	At 12V, 10A
	Typ.	92.2%	92.9%	93.8%	At 12V, 12A (PowerBoost)
Average efficiency*)	Typ.	91.6%	92.0%	92.3%	25% at 2.5A, 25% at 5A, 25% at 7.5A. 25% at 10A
Power losses	Typ.	0.9W	0.9W	1.0W	At 12V, 0A
	Typ.	4.9W	4.7W	4.6W	At 12V, 5A
	Typ.	9.6W	8.8W	7.7W	At 12V, 10A
	Typ.	12.2W	11.0W	9.5W	At 12V, 12A (PowerBoost)

\*) The average efficiency is an assumption for a typical application where the power supply is loaded with 25% of the nominal load for 25% of the time, 50% of the nominal load for another 25% of the time, 75% of the nominal load for another 25% of the time and with 100% of the nominal load for the rest of the time.

**Fig. 9-1 Efficiency vs. output current at 12V, typ**

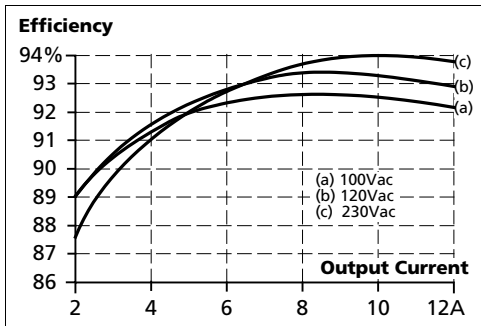

**Fig. 9-2 Losses vs. output current at 12V, typ.**

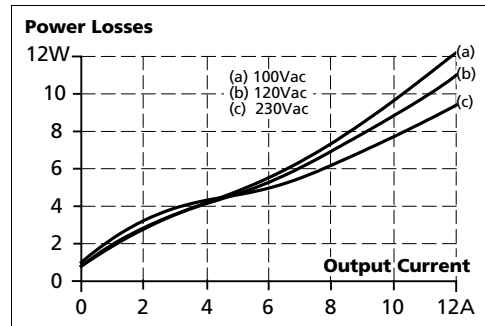

**Fig. 9-3 Efficiency vs. input voltage at 12V, 10A, typ.**

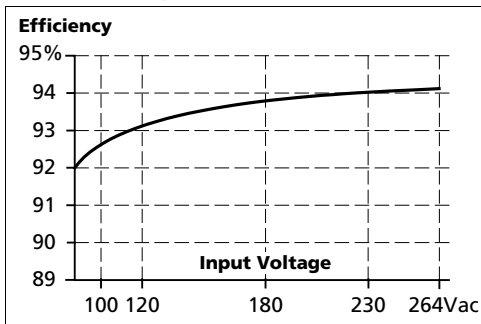

**Fig. 9-4 Losses vs. input voltage at 12V, 10A, typ.**

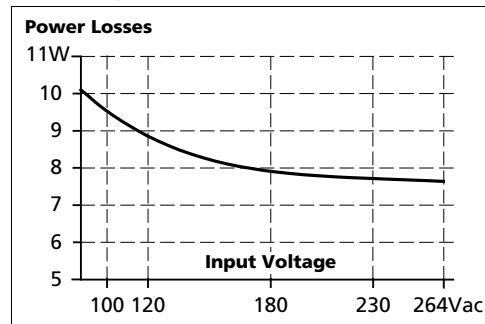

## 10. FUNCTIONAL DIAGRAM

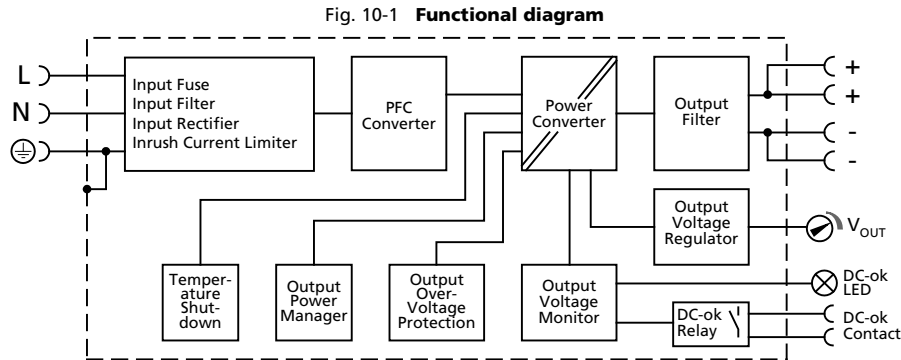

## 11. FRONT SIDE AND USER ELEMENTS

Fig. 11-1 **Front side**



### **A Input Terminals**

- N, L** Line input
- $\oplus$  PE (Protective Earth) input

### **B Output Terminals**

- Two identical + poles and two identical - poles
- +** Positive output
- Negative (return) output

### **C Output Voltage Potentiometer**

### **D DC-OK LED (green)**

On, when the output voltage is >90% of the adjusted output voltage

### **E DC-OK Relay Contact**

The DC-OK relay contact is synchronized with the DC-OK LED. See chapter 8 for details.

## 12. TERMINALS AND WIRING

The terminals are IP20 Finger safe constructed and suitable for field- and factory wiring.

	Input	Output	DC-OK signal
Type	Screw terminal	Screw terminal	Push-in terminal
Solid wire	Max. 6mm <sup>2</sup>	Max. 6mm <sup>2</sup>	Max. 1.5mm <sup>2</sup>
Stranded wire	Max. 4mm <sup>2</sup>	Max. 4mm <sup>2</sup>	Max. 1.5mm <sup>2</sup>
American Wire Gauge	AWG 20-10	AWG 20-10	AWG 24-16
Max. wire diameter (including ferrules)	2.8mm	2.8mm	1.6mm
Recommended tightening torque	1Nm	1Nm	-
Wire stripping length	7mm	7mm	8mm
Screwdriver	3.5mm slotted or cross-head No 2	3.5mm slotted or cross-head No 2	3mm slotted to open the spring

### Daisy chaining:

Daisy chaining (jumping from one power supply output to the next) is allowed as long as the average output current through one terminal pin does not exceed 25A. If the current is higher, use a separate distribution terminal block as shown in Fig. 12-2.

Fig. 12-1 Daisy chaining of outputs

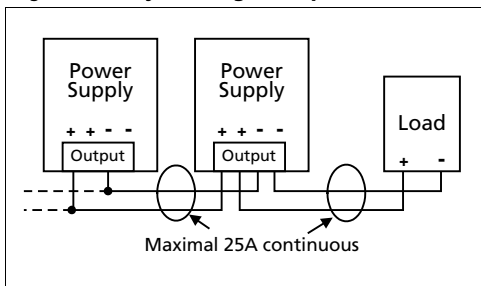
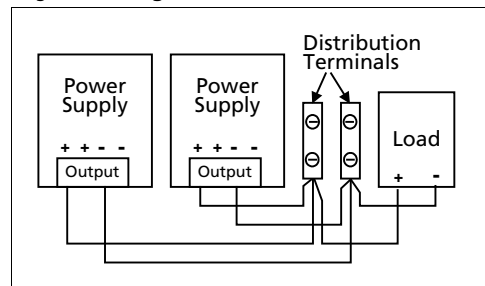

Fig. 12-2 Using distribution terminals



### 13. LIFETIME EXPECTANCY

The Lifetime expectancy shown in the table indicates the minimum operating hours (service life) and is determined by the lifetime expectancy of the built-in electrolytic capacitors. Lifetime expectancy is specified in operational hours and is calculated according to the capacitor's manufacturer specification. The manufacturer of the electrolytic capacitors only guarantees a maximum life of up to 15 years (131 400h). Any number exceeding this value is a calculated theoretical lifetime which can be used to compare devices.

	<b>AC 100V</b>	<b>AC 120V</b>	<b>AC 230V</b>	
Lifetime expectancy	284 000h	297 000h	294 000h	At 12V, 5A and 40°C
	804 000h	839 000h	833 000h	At 12V, 5A and 25°C
	88 000h	94 000h	110 000h	At 12V, 10A and 40°C
	248 000h	267 000h	311 000h	At 12V, 10A and 25°C
	44 000h	51 000h	61 000h	At 12V, 12A and 40°C
	126 000h	143 000h	171 000h	At 12V, 12A and 25°C

### 14. MTBF

MTBF stands for **Mean Time Between Failure**, which is calculated according to statistical device failures, and indicates reliability of a device. It is the statistical representation of the likelihood of a unit to fail and does not necessarily represent the life of a product.

The MTBF figure is a statistical representation of the likelihood of a device to fail. A MTBF figure of e.g. 1 000 000h means that statistically one unit will fail every 100 hours if 10 000 units are installed in the field. However, it can not be determined if the failed unit has been running for 50 000h or only for 100h.

For these types of units the MTTF (**Mean Time To Failure**) value is the same value as the MTBF value.

	<b>AC 100V</b>	<b>AC 120V</b>	<b>AC 230V</b>	
MTBF SN 29500, IEC 61709	682 000h	687 000h	732 000h	At 12V, 10A and 40°C
	1 212 000h	1 221 000h	1 294 000h	At 12V, 10A and 25°C
MTBF MIL HDBK 217F	287 000h	290 000h	308 000h	At 12V, 10A and 40°C; Ground Benign GB40
	417 000h	421 000h	447 000h	At 12V, 10A and 25°C; Ground Benign GB25
	68 000h	69 000h	73 000h	At 12V, 10A and 40°C; Ground Fixed GF40
	91 000h	93 000h	99 000h	At 12V, 10A and 25°C; Ground Fixed GF25

## 15. EMC

The EMC behavior of the device is designed for applications in industrial environment as well as in residential, commercial and light industry environments.

The device is investigated according to EN 61000-6-1, EN 61000-6-2, EN 61000-6-3 and EN 61000-6-4.

### EMC Immunity

Electrostatic discharge	EN 61000-4-2	Contact discharge Air discharge	8kV 15kV	Criterion A Criterion A
Electromagnetic RF field	EN 61000-4-3	80MHz-2.7GHz	20V/m	Criterion A
Fast transients (Burst)	EN 61000-4-4	Input lines Output lines DC-OK signal (coupling clamp)	4kV 2kV 2kV	Criterion A Criterion A Criterion A
Surge voltage on input	EN 61000-4-5	L → N L → PE, N → PE	2kV 4kV	Criterion A Criterion A
Surge voltage on output	EN 61000-4-5	+ → - + / - → PE	1kV 2kV	Criterion A Criterion A
Surge voltage on DC-OK	EN 61000-4-5	DC-OK signal → PE	1kV	Criterion A
Conducted disturbance	EN 61000-4-6	0.15-80MHz	20V	Criterion A
Mains voltage dips	EN 61000-4-11	0% of 100Vac 40% of 100Vac 70% of 100Vac 0% of 200Vac 40% of 200Vac 40% of 200Vac 70% of 200Vac	0Vac, 20ms 40Vac, 200ms 70Vac, 500ms 0Vac, 20ms 80Vac, 200ms <8A 80Vac, 200ms >8A 140Vac, 500ms	Criterion A Criterion C Criterion A Criterion A Criterion A Criterion C Criterion A
Voltage interruptions	EN 61000-4-11	0% of 200Vac (=0V)	5000ms	Criterion C
Powerful transients	VDE 0160	Over entire load range	750V, 0.3ms	Criterion A

### Performance criterions:

**A:** The device shows normal operation behavior within the defined limits.

**C:** Temporary loss of function is possible. The device may shut-down and restarts by itself. No damage or hazards for the device will occur.

### EMC Emission

Conducted emission input lines	EN 55011, EN 55032, FCC Part 15, CISPR 11, CISPR 32	Class B
Conducted emission output lines	IEC/CISPR 16-1-2, IEC/CISPR 16-2-1	Limits for local DC power networks fulfilled
Radiated emission	EN 55011, EN 55032	Class B
Harmonic input current (PFC)	EN 61000-3-2	Fulfilled for Class A equipment
Voltage fluctuations, flicker	EN 61000-3-3	Fulfilled: tested with constant current loads, non pulsing

This device complies with FCC Part 15 rules.

Operation is subjected to following two conditions: (1) this device may not cause harmful interference, and (2) this device must accept any interference received, including interference that may cause undesired operation.

### Switching Frequencies

PFC converter	30kHz to 140kHz	Input voltage and output power dependent
Main converter	60kHz to 140kHz	Output load dependent
Auxiliary converter	30kHz to 60kHz	Output load dependent

## 16. ENVIRONMENT

Operational temperature	-25°C to +70°C	Operational temperature is the same as the ambient or surrounding temperature and is defined as the air temperature 2cm below the unit.
Storage temperature	-40°C to +85°C	For storage and transportation
Output derating	3W/K 0.67A/1000m or 5K/1000m The derating is not hardware controlled. The user has to take care by himself to stay below the derated current limits in order not to overload the unit.	Between +60°C and +70°C For altitudes >2000m, see Fig. 16-2
Humidity	5 to 95% r.h.	According to IEC 60068-2-30
Atmospheric pressure	110-54kPa	See Fig. 16-2 for details
Altitude	Up to 5000m	See Fig. 16-2 for details
Overvoltage category	III	According to IEC 60664-1 for altitudes up to 2000m
	II	According to IEC 60664-1, for altitudes above 2000m
Degree of pollution	2	According to IEC 62477-1, not conductive
Vibration sinusoidal	2-17.8Hz: ±1.6mm; 17.8-500Hz: 2g 2 hours / axis	According to IEC 60068-2-6
Shock	30g 6ms, 20g 11ms 3 bumps / direction, 18 bumps in total	According to IEC 60068-2-27
	Shock and vibration is tested in combination with DIN rails according to EN 60715 with a height of 15mm and a thickness of 1.3mm and standard orientation.	
Audible noise	Some audible noise may be emitted from the power supply during no load, overload or short circuit.	

Fig. 16-1 **Output current vs. ambient temp**  
(Inom 10A; Iout with PowerBoost = 12A)

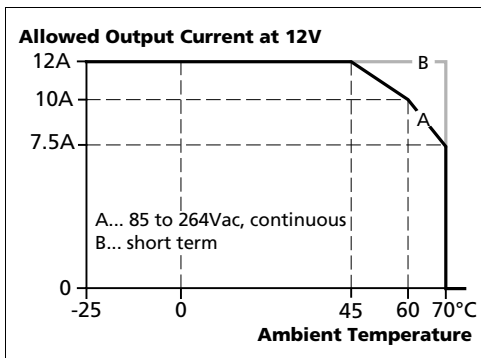
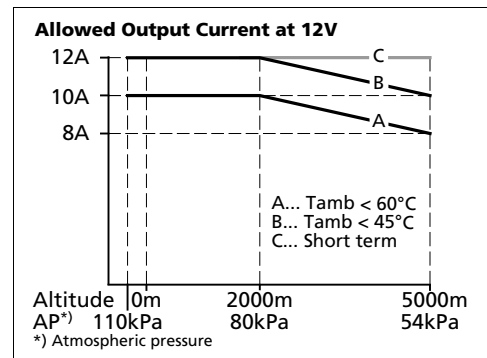

Fig. 16-2 **Output current vs. altitude**



## 17. SAFETY AND PROTECTION FEATURES

Isolation resistance	Min.	500MΩ	At delivered condition between input and output, measured with 500Vdc
	Min.	500MΩ	At delivered condition between input and PE, measured with 500Vdc
	Min.	500MΩ	At delivered condition between output and PE, measured with 500Vdc
	Min.	500MΩ	At delivered condition between output and DC-OK contacts, measured with 500Vdc
PE resistance	Max.	0.1Ω	Resistance between PE terminal and the housing in the area of the DIN rail mounting bracket.
Output overvoltage protection	Typ.	17.5Vdc	In case of an internal defect, a redundant circuit limits the maximum output voltage. The output shuts down and performs three restart attempts. If the failure continues, the output shuts down. Cycle input power to reset.
	Max.	19Vdc	
Class of protection		I	According to IEC 61140 A PE (Protective Earth) connection is required
Degree of protection		IP20	According to EN/IEC 60529
Overtemperature protection		Included	Output shut-down with automatic restart. Temperature sensors are installed on critical components inside the unit and turn the unit off in safety critical situations, which can happen e.g. when ambient temperature is too high, ventilation is obstructed or the derating requirements are not followed. There is no correlation between the operating temperature and turn-off temperature since this is dependent on input voltage, load and installation methods.
Input transient protection		MOV (Metal Oxide Varistor)	For protection values see chapter 15 (EMC).
Internal input fuse		Included	Not user replaceable slow-blow high-breaking capacity fuse
Touch current (leakage current)	Typ.	0.10mA / 0.27mA	At 100Vac, 50Hz, TN-,TT-mains / IT-mains
	Typ.	0.13mA / 0.38mA	At 120Vac, 60Hz, TN-,TT-mains / IT-mains
	Typ.	0.20mA / 0.60mA	At 230Vac, 50Hz, TN-,TT-mains / IT-mains
	Max.	0.13mA / 0.35mA	At 110Vac, 50Hz, TN-,TT-mains / IT-mains
	Max.	0.17mA / 0.51mA	At 132Vac, 60Hz, TN-,TT-mains / IT-mains
	Max.	0.27mA / 0.81mA	At 264Vac, 50Hz, TN-,TT-mains / IT-mains

## 18. DIELECTRIC STRENGTH

The output voltage is floating and has no ohmic connection to the ground.

The output is insulated to the input by a double or reinforced insulation.

Type and routine tests are conducted by the manufacturer. Field tests may be conducted in the field using the appropriate test equipment which applies the voltage with a slow ramp (2s up and 2s down). Connect all input-terminals together as well as all output poles before conducting the test. When testing, set the cut-off current settings to the value in the table below.

We recommend that either the + pole or the – pole shall be connected to the protective earth system. This helps to avoid situations in which a load starts unexpectedly or cannot be switched off when unnoticed earth faults occur.

Fig. 18-1 Dielectric strength

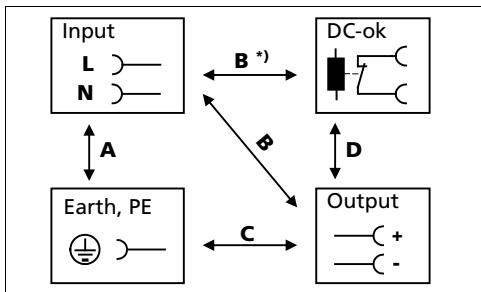

		<b>A</b>	<b>B</b>	<b>C</b>	<b>D</b>
Type test	60s	2500Vac	3000Vac	1000Vac	500Vac
Routine test	5s	2500Vac	2500Vac	500Vac	500Vac
Field test	5s	2000Vac	2000Vac	500Vac	500Vac
Field tests cut-off current settings		> 10mA	> 10mA	> 20mA	> 1mA





B<sup>\*)</sup>

When testing input to DC-OK ensure that the maximal voltage between DC-OK and the output is not exceeded (column D). We recommend connecting DC-OK pins and the output pins together when performing the test.

**19. APPROVED, FULFILLED OR TESTED STANDARDS**

IEC 61010-2-201	<b>CB Report</b>	CB Scheme Certificate Electrical Equipment for Measurement, Control and Laboratory Use - Particular requirements for control equipment
UL 61010-2-201		UL Certificate Listed equipment for category NMTR - Electrical Equipment for Measurement, Control and Laboratory Use - Particular requirements for control equipment Applicable for US and Canada E-File: E198865
IEC 62368	<b>CB Report</b>	CB Scheme Certificate IEC 62368-1 Audio/video, information and communication technology equipment - Safety requirements Output safety level: E51
ATEX		Agency Certificate (Bureau Veritas) EN 60079-0 Explosive atmospheres - General requirements EN 60079-7, EN 60079-15 Equipment protection by type of protection "e" and "n" Certificate: EPS 19 ATEX 1 201 X Temperature Code: T4 Type of Protection: ec nC
IECEX	<b>IECEX</b>	IECEX Certificate IEC 60079-0 Explosive atmospheres - General requirements IEC 60079-7, IEC 60079-15 Equipment protection by type of protection "e" and "n" Certificate: IECEX EPS 19.0078X Temperature Code: T4 Type of Protection: ec nC
Class I Div 2		UL Certificate Listed equipment for category NRAD - Listed equipment Industrial Control Equipment for Use in Hazardous Locations Applicable for US and Canada E-File: E327416 Temperature Code: T4 Groups: A, B, C and D
IEC 61558-2-16	<b>Safety Isolating Transformer IEC 61558-2-16</b>	Test Certificate Safety of transformers, reactors, power supply units and similar products for supply voltages up to 1100 V Particular requirements and tests for switch mode power supply units and transformers for switch mode power supply units
VDMA 24364	<b>LABS</b> VDMA 24364-C1-L/W	Paint Wetting Impairment Substances Test (or LABS-Test) Tested for Zone 2 and test class C1 according to VDMA 24364-C1-L/W for solvents and water-based paints

## 20. REGULATORY PRODUCT COMPLIANCE

EU Declaration of Conformity		The CE mark indicates conformance with the - EMC directive - Low-voltage directive - RoHS directive
REACH Regulation (EU)		Manufacturer's Declaration EU regulation regarding the Registration, Evaluation, Authorisation and Restriction of Chemicals (REACH) fulfilled. EU Regulation (EC) 1907/2006.
WEEE Regulation		Manufacturer's Declaration EU Regulation on Waste Electrical and Electronic Equipment Registered as business to business (B2B) products. EU Regulation 2012/19/EU
CCC		CCC Certificate China Compulsory Certification (CNCA-C23-01:2019) Certificate for devices made in Suzhou/China (PULS Electronics): 2021122303114443 Certificate for devices made in Chomutov/Czech Republic (PULS investiční): 2021122303114444 CCC-Ex
KC		KC Korean Certification Korean - Registration of Broadcasting and Communication Equipment Registered under Clause3, Article 58-2 of Radio Waves Act. Registration No. R-R-PUG-CP5_121.

## 21. PHYSICAL DIMENSIONS AND WEIGHT

Width	32mm
Height	124mm
Depth	102mm
	The DIN rail depth must be added to the unit depth to calculate the total required installation depth.

Weight	440g
DIN rail	Use 35mm DIN rails according to EN 60715 or EN 50022 with a height of 7.5 or 15mm.
Housing material	Body: Aluminium alloy Cover: Zinc-plated steel
Installation clearances	See chapter 2
Penetration protection	Small parts like screws, nuts, etc. with a diameter larger than 3.5mm

Fig. 21-1 Front view

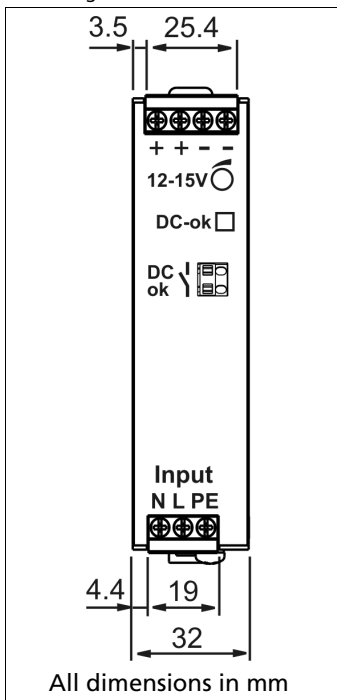
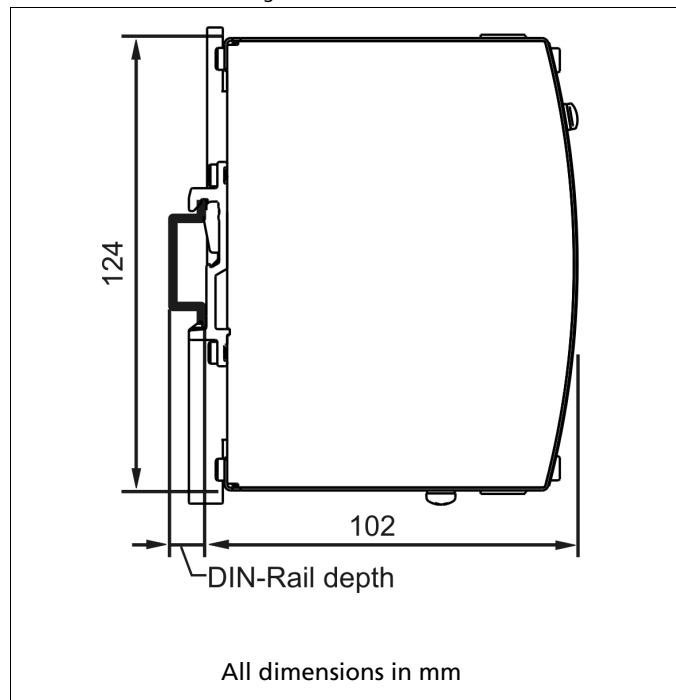

Fig. 21-2 Side view



## 22. ACCESSORIES

### 22.1. ZM10.WALL - WALL/PANEL MOUNT BRACKET

This bracket is used to mount the devices on a wall/panel without utilizing a DIN rail. The bracket can be mounted without detaching the DIN rail brackets.

Fig. 22-1 **Isometric view**

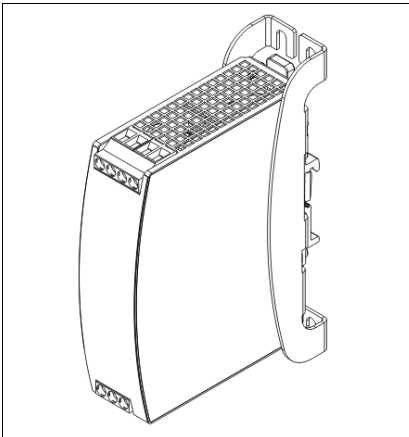

Fig. 22-2 **Isometric view**

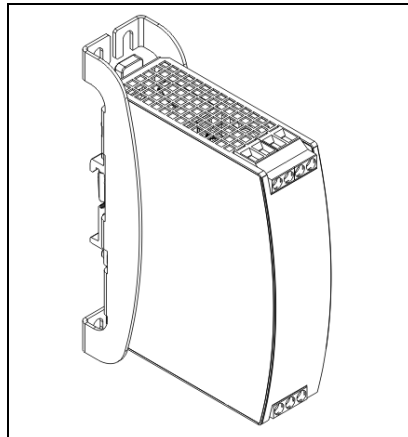

Fig. 22-3 **Isometric view**

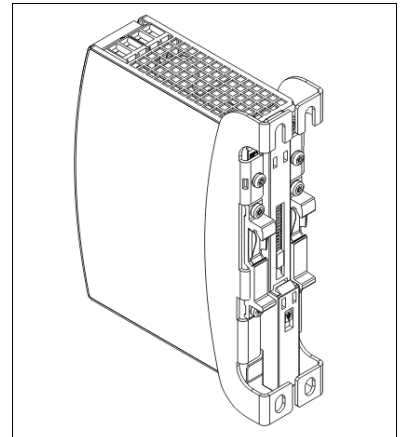

Fig. 22-4 **Wall/panel mounting, front view**

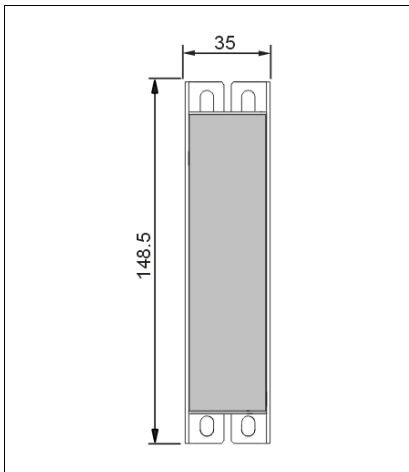

Fig. 22-5 **Hole pattern for wall mounting**

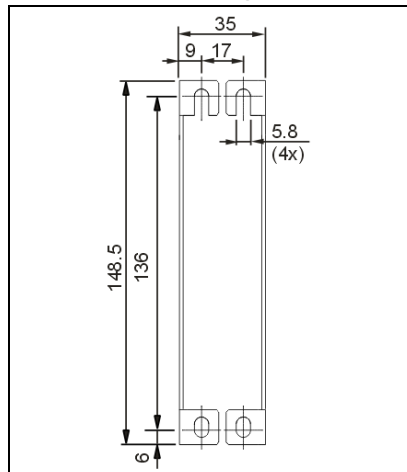
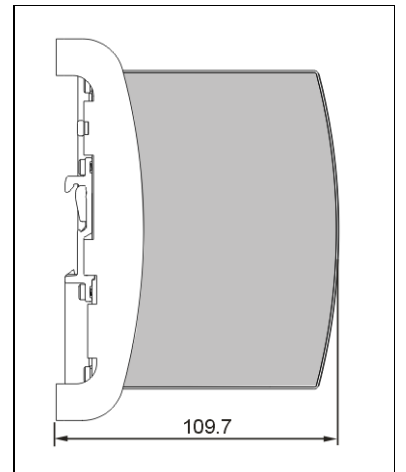

Fig. 22-6 **Wall/panel mounting, side view**



## 22.2. YR20.242 - REDUNDANCY MODULE



The YR20.242 is a dual redundancy module, which can be used to build 1+1 or N+1 redundant systems.

The device is equipped with two input channels, each rated for 20A for ambient temperatures up to +70°C and are individually decoupled by utilizing MOSFET technology. The inputs can also be operated up to 24A when the ambient temperature does not exceed +45°C.

The output can be loaded with nominal 20A at +70°C or 24A at 45°C continuous current.

Using MOSFETs instead of diodes reduces heat generation, losses and voltage drop between input and output. Due to these advantages, the unit is very narrow and only requires 32mm width on the DIN rail.

The device does not require an additional auxiliary voltage and is self-powered even in case of a short circuit across the output.

See chapter 23.5 for wiring information.

## 23. APPLICATION NOTES

### 23.1. PEAK CURRENT CAPABILITY

The unit can deliver peak currents (up to several milliseconds) which are higher than the specified short term currents. This helps to start current demanding loads. Solenoids, contactors and pneumatic modules often have a steady state coil and a pick-up coil. The inrush current demand of the pick-up coil is several times higher than the steady-state current and usually exceeds the nominal output current. The same situation applies when starting a capacitive load. The peak current capability also ensures the safe operation of subsequent circuit breakers of load circuits. The load branches are often individually protected with circuit breakers or fuses. In case of a short or an overload in one branch circuit, the fuse or circuit breaker need a certain amount of overcurrent to open in a timely manner. This avoids voltage loss in adjacent circuits.

The extra current (peak current) is supplied by the power converter and the built-in large sized output capacitors of the power supply. The capacitors get discharged during such an event, which causes a voltage dip on the output. The following two examples show typical voltage dips for resistive loads:

**Fig. 23-1 20A peak current for 50ms , typ. (2x the nominal current)**

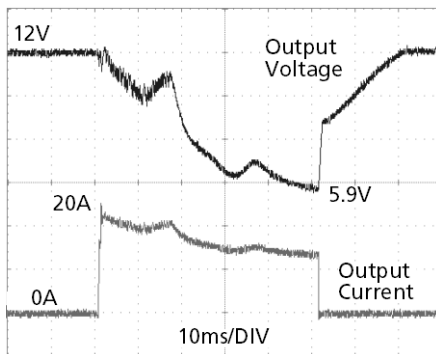

**Fig. 23-2 50A peak current for 5ms , typ. (5x the nominal current)**

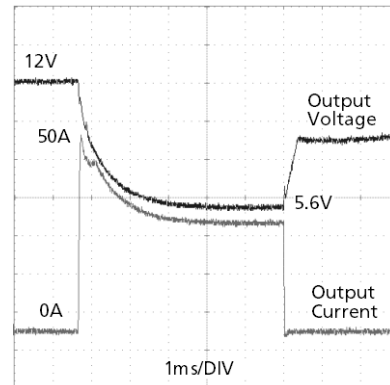

**Fig. 23-3 30A peak current for 12ms , typ. (3x the nominal current)**

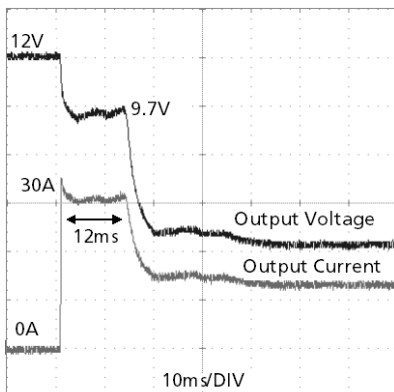

Please note: The DC-OK relay triggers when the voltage dips more than 10% for longer than 1ms.

Peak current voltage dips	Typically from 12V to 5.9V	At 20A for 50ms, resistive load
	Typically from 12V to 6V	At 50A for 2ms, resistive load
	Typically from 12V to 5.6V	At 50A for 5ms, resistive load

### 23.2. CHARGING OF BATTERIES

The power supply can be used to charge lead-acid or maintenance free VRLA batteries.

**Instructions for charging batteries:**

- a) Ensure that the ambient temperature of the power supply stays below 40°C for mains voltage of AC 120V or higher and 35°C for a mains voltage of AC 100V.
- b) Use a 15A or 16A circuit breaker or a blocking diode between the power supply and the battery.
- c) Ensure that the output current of the power supply is below the allowed charging current of the battery.
- d) The return current to the power supply is typically 8mA. This return current can discharge the battery when the power supply is switched off except in case a blocking diode is utilized.
- e) Set the output voltage, measured at no load and at the battery end of the cable, very precisely to the end-of-charge voltage. Set the output voltage, measured at no load and at the battery end of the cable, very precisely to the end-of-charge voltage. The voltage should be set to 13.9V at 10°C, 13.75V at 20°C, 13.6V at 30°C and 13.4V at 40°C ambient temperature.

### 23.3. SERIES OPERATION

Devices of the same type can be connected in series for higher output voltages. It is possible to connect as many units in series as needed, providing the sum of the output voltage does not exceed 150Vdc. Voltages with a potential above 60Vdc must be installed with a protection against touching.

Avoid return voltage (e.g. from a decelerating motor or battery) which is applied to the output terminals.

Keep an installation clearance of 15mm (left / right) between two power supplies and avoid installing the power supplies on top of each other. Do not use power supplies in series in mounting orientations other than the standard mounting orientation.

Pay attention that leakage current, EMI, inrush current, harmonics will increase when using multiple devices.

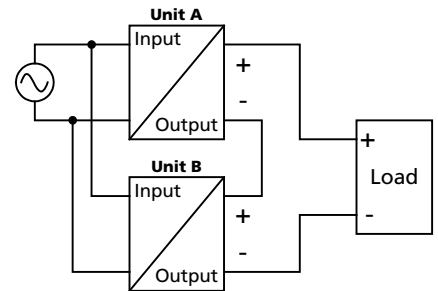

### 23.4. PARALLEL USE TO INCREASE OUTPUT POWER

Devices can be paralleled to increase the output power. The output voltage shall be adjusted to the same value (±100mV) with the same load conditions on all devices, or the devices can be left with the factory settings.

The ambient temperature is not allowed to exceed +40°C.

If more than three devices are connected in parallel, a fuse or circuit breaker with a rating of 15A or 16A is required on each output. Alternatively, a diode or redundancy module can also be utilized.

Energize all devices at the same time. It also might be necessary to cycle the input power (turn-off for at least five seconds), if the output was in overload or short circuits and the required output current is higher than the current of one unit.

Keep an installation clearance of 15mm (left / right) between two devices and avoid installing devices on top of each other. Do not use devices in parallel in mounting orientations other than the standard mounting orientation or in any other condition where a reduction of the output current is required (e.g. altitude).

Pay attention that leakage current, EMI, inrush current will increase when using multiple devices.

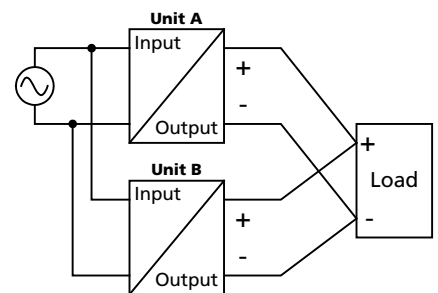

### 23.5. PARALLEL USE FOR REDUNDANCY

#### 1+1 Redundancy:

Devices can be paralleled for redundancy to gain higher system availability. Redundant systems require a certain amount of extra power to support the load in case one device fails. The simplest way is to put two devices in parallel. This is called a 1+1 redundancy. In case one device fails, the other one is automatically able to support the load current without any interruption. It is essential to use a redundancy module to decouple devices from each other. This prevents that the defective unit becomes a load for the other device and the output voltage cannot be maintained any more.

1+1 redundancy allows ambient temperatures up to +70°C.

Pay attention that leakage current, EMI, inrush current, harmonics will increase when using multiple devices.

Recommendations for building redundant power systems:

- Use separate input fuses for each device.
- Use separate mains systems for each device whenever it is possible.
- Monitor the individual devices. Therefore, use the DC-OK signal of the device.
- It is desirable to set the output voltages of all devices to the same value ( $\pm 100\text{mV}$ ) or leave it at the factory setting.

#### N+1 Redundancy:

Redundant systems for a higher power demand are usually built in a N+1 method. E.g. four devices, each rated for 10A are paralleled to build a 30A redundant system.

Pay attention that leakage current, EMI, inrush current, harmonics will increase when using multiple devices.

Keep an installation clearance of 15mm (left / right) between two devices and avoid installing the devices on top of each other.

Do not use devices in parallel in mounting orientations other than the standard mounting orientation or in any other condition, where a reduction of the output current is required.

For N+1 redundancy the ambient temperature is not allowed to exceed +40°C.

#### Wiring examples:

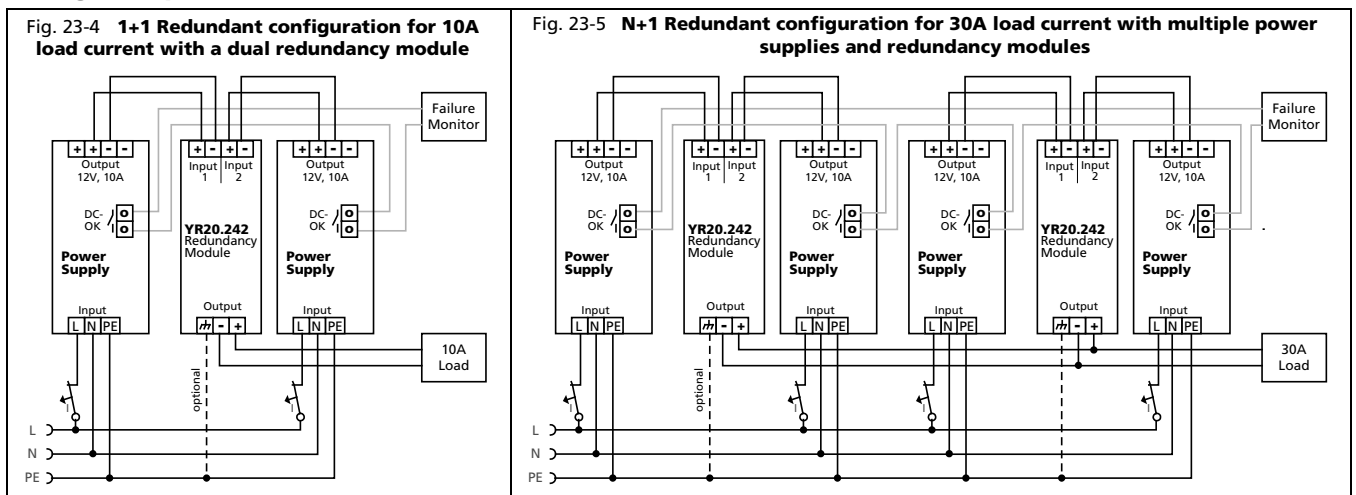

### 23.6. OPERATION ON TWO PHASES

The power supply can also be used on two-phases of a three-phase-system. Such a phase-to-phase connection is allowed as long as the supplying voltage is below 240V<sup>+10%</sup>.

Ensure that the wire, which is connected to the N-terminal, is appropriately fused.

The maximum allowed voltage between a Phase and the PE must be below 300Vac.

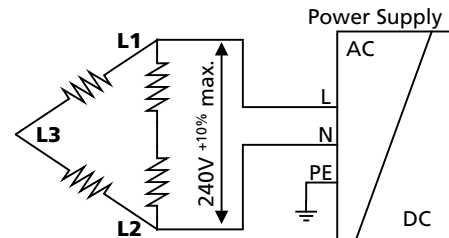

### 23.7. USE IN A TIGHTLY SEALED ENCLOSURE

When the device is installed in a tightly sealed enclosure, the temperature inside the enclosure will be higher than outside. In such situations, the inside temperature defines the ambient temperature for the device.

In the following test setup, the device is placed in the middle of the box, no other heat producing items are inside the box. The load is placed outside the box.

The temperature sensor inside the box is placed in the middle of the right side of the power supply with a distance of 1cm.

The following measurement results can be used as a reference to estimate the temperature rise inside the enclosure.

	<b>Case A</b>	<b>Case B</b>
Enclosure size	110x180x165mm Rittal Typ IP66 Box PK 9516 100, plastic	110x180x165mm Rittal Typ IP66 Box PK 9516 100, plastic
Input voltage	230Vac	230Vac
Load	12V, 8A; (=80%)	12V, 10A; (=100%)
Temperature inside the box	40.7°C	43.2°C
Temperature outside the box	27.9°C	28.0°C
Temperature rise	12.8K	15.2K

### 23.8. MOUNTING ORIENTATIONS

Mounting orientations other than input terminals on the bottom and output on the top require a reduction in continuous output power or a limitation in the maximum allowed ambient temperature.

The listed lifetime and MTBF values from this datasheet apply only for the standard mounting orientation.

The following curves give an indication for allowed output currents for altitudes up to 2000m.

Fig. 23-6  
**Mounting Orientation A**  
(Standard orientation)

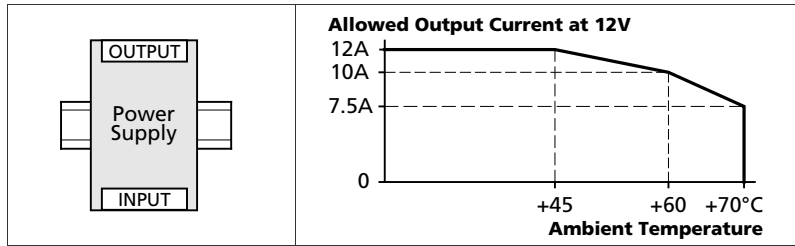

Fig. 23-7  
**Mounting Orientation B**  
(Upside down)

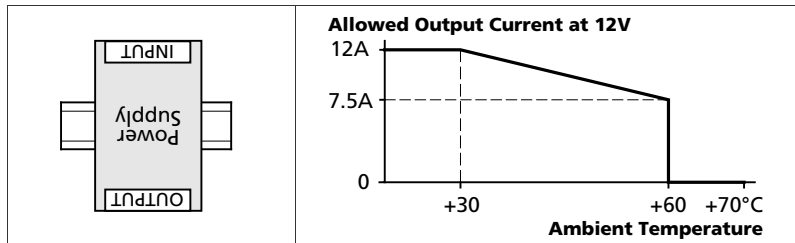

Fig. 23-8  
**Mounting Orientation C**  
(Table-top mounting)

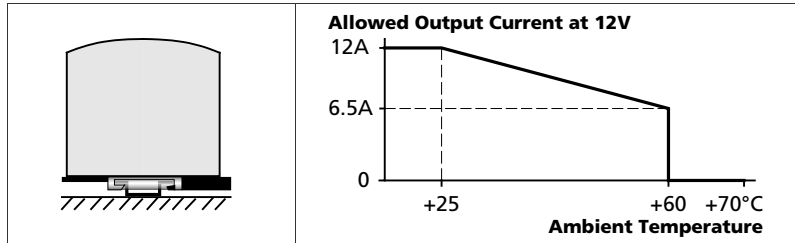

Fig. 23-9  
**Mounting Orientation D**  
(Horizontal cw)

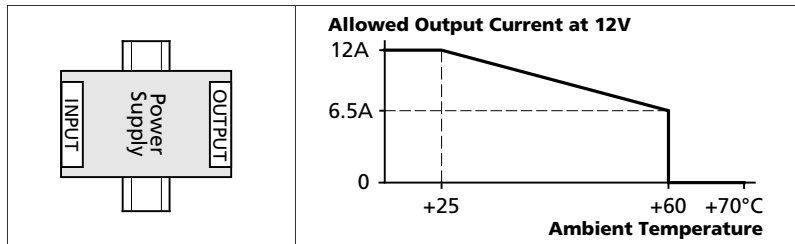

Fig. 23-10  
**Mounting Orientation E**  
(Horizontal ccw)

