



## POWER SUPPLY

- AC 380-480V Wide-range Input
- Input Fuses Already Included
- Requires only Two Legs of a 3-Phase System
- Width only 40mm
- Efficiency up to 85.8%
- Input -Transient Blanking Circuit Included
- Minimal Inrush Current Surge
- Full Power Between -25°C and +60°C
- 3 Year Warranty

## PRODUCT DESCRIPTION

The Dimension CT-Series are cost optimized power supplies without compromising quality, reliability and performance. The CT-Series is part of the DIMENSION power supply family. The most outstanding features of CT5.121 are the high efficiency, electronic inrush current limitation, active input transient filter and wide operational temperature range, the small size and other technological design concepts.

The CT-Series includes all the essential basic functions. The CT5.121 utilizes only 2 legs of a 3-phase system which saves wiring and installation costs. Furthermore, this allows a smaller unit without compromising the size of the terminals. Due to the low power consumption, an unbalancing of the individual phases is not expected.

## SHORT-FORM DATA

Output voltage	DC 12V	Nominal
Adjustment range	12 - 15V	Factory setting 12.0V
Output current	8.0 – 6.4A	Up to +60°C ambient
	6.0 – 4.8A	At +70°C ambient
	Derate linearly between +60°C and +70°C	
Input voltage AC	AC 380-480V	-15%/+20%
Mains frequency	50-60Hz	±6%
Input current AC	0.64 / 0.56A	At 400 / 480Vac
Power factor	0.44 / 0.42	At 400 / 480Vac
AC Inrush current	4 / 4Apk	At 400 / 480Vac
Efficiency	85.4 / 85.8%	At 400 / 480Vac
Losses	16.4 / 15.9W	At 400 / 480Vac
Hold-up time	43 / 63ms	At 400 / 480Vac
Temperature range	-25°C to +70°C	
Size (WxHxD)	40x124x117mm	Without DIN rail
Weight	500g	

## ORDER NUMBERS

Power Supply	<b>CT5.121</b>	
Accessory	ZM1.WALL	Wall/panel mount bracket
	ZM12.SIDE	Side mount bracket

## MAIN APPROVALS

For details or a complete approval list see chapter 18.



UL 508



UL 60950-1



Class I Div 2



Marine



Marine



## INDEX

	Page		Page
1. Intended Use .....	3	17. Dielectric Strength.....	16
2. Installation Instructions .....	3	18. Approved, Fulfilled or Tested Standards.....	17
3. AC-Input.....	5	19. Regulatory Product Compliance .....	18
4. DC-Input.....	6	20. Physical Dimensions and Weight .....	19
5. Input Inrush Current .....	6	21. Accessories .....	20
6. Output .....	7	21.1. ZM1.WALL - Wall/Panel Mount Bracket ..	20
7. Hold-up Time.....	8	21.2. ZM12.SIDE - Side Mount Bracket .....	21
8. Efficiency and Power Losses.....	9	22. Application Notes.....	22
9. Functional Diagram.....	10	22.1. Peak Current Capability .....	22
10. Front Side and User Elements.....	10	22.2. Charging of Batteries .....	23
11. Connection Terminals .....	11	22.3. Series Operation .....	23
12. Lifetime Expectancy .....	12	22.4. Parallel Use to Increase Output Power....	23
13. MTBF .....	12	22.5. Use in a Tightly Sealed Enclosure .....	24
14. EMC.....	13	22.6. Mounting Orientations .....	25
15. Environment.....	14		
16. Safety and Protection Features .....	15		

The information given in this document is correct to the best of our knowledge and experience at the time of publication. If not expressly agreed otherwise, this information does not represent a warranty in the legal sense of the word. As the state of our knowledge and experience is constantly changing, the information in this data sheet is subject to revision. We therefore kindly ask you to always use the latest issue of this document (available under [www.pulspower.com](http://www.pulspower.com)).

No part of this document may be reproduced or utilized in any form without our prior permission in writing.

## TERMINOLOGY AND ABBREVIATIONS

<b>PE and  symbol</b>	PE is the abbreviation for <b>Protective Earth</b> and has the same meaning as the symbol  .
<b>Earth, Ground</b>	This document uses the term "earth" which is the same as the U.S. term "ground".
<b>t.b.d.</b>	To be defined, value or description will follow later.
<b>AC 400V</b>	A figure displayed with the AC or DC before the value represents a nominal voltage with standard tolerances (usually $\pm 15\%$ ) included. E.g.: DC 12V describes a 12V battery disregarding whether it is full (13.7V) or flat (10V)
<b>400Vac</b>	A figure with the unit (Vac) at the end is a momentary figure without any additional tolerances included.
<b>50Hz vs. 60Hz</b>	As long as not otherwise stated, AC 380V and AC 400V parameters are valid at 50Hz and AC 480V parameters are valid at 60Hz mains frequency.
<b>may</b>	A key word indicating flexibility of choice with no implied preference.
<b>shall</b>	A key word indicating a mandatory requirement.
<b>should</b>	A key word indicating flexibility of choice with a strongly preferred implementation.

## 1. INTENDED USE

This device is designed for installation in an enclosure and is intended for commercial use, such as in industrial control, process control, monitoring and measurement equipment or the like.

Do not use this device in equipment, where malfunctioning may cause severe personal injury or threaten human life without additional appropriate safety devices, that are suited for the end-application.

If this device is used in a manner outside of its specification, the protection provided by the device may be impaired.

## 2. INSTALLATION INSTRUCTIONS

### **⚠ WARNING Risk of electrical shock, fire, personal injury or death.**

- Turn power off before working on the device and protect against inadvertent re-powering.
- Do not open, modify or repair the device.
- Use caution to prevent any foreign objects from entering into the housing.
- Do not use in wet locations or in areas where moisture or condensation can be expected.
- Do not touch during power-on, and immediately after power-off. Hot surface may cause burns.

### **Obey the following installation instructions:**

This device may only be installed and put into operation by qualified personnel.

This device does not contain serviceable parts. The tripping of an internal fuse is caused by an internal defect.

If damage or malfunction should occur during installation or operation, immediately turn power off and send unit to the factory for inspection.

Install device in an enclosure providing protection against electrical, mechanical and fire hazards.

Install the device onto a DIN rail according to EN 60715 with the input terminals on the bottom of the device. Other mounting orientations require a reduction in output current.

Make sure that the wiring is correct by following all local and national codes. Use appropriate copper cables that are designed for a minimum operating temperature of 60°C for ambient temperatures up to +45°C, 75°C for ambient temperatures up to +60°C and 90°C for ambient temperatures up to +70°C.

Ensure that all strands of a stranded wire enter the terminal connection. Use ferrules for wires on the input terminals. Unused screw terminals should be securely tightened.

The device is designed for pollution degree 2 areas in controlled environments. No condensation or frost is allowed.

The enclosure of the device provides a degree of protection of IP20. The housing does not provide protection against spilled liquids.

The device is designed for overvoltage category II zones. Below 2000m altitude the device is tested for impulse withstand voltages up to 4kV, which corresponds to OVC III according to IEC 60664-1.

The device is designed as "Class of Protection I" equipment according to IEC 61140. Do not use without a proper PE (Protective Earth) connection.

The device is suitable to be supplied from TN, TT or IT mains networks.

The continuous voltage between the input terminals and the PE potential must not exceed 500Vac. Corner grounded delta systems are allowed.

A disconnecting means shall be provided for the input of the device.

The device is designed for convection cooling and does not require an external fan. Do not obstruct airflow and do not cover ventilation grid!

The device is designed for altitudes up to 5000m. Above 2000m a reduction in output current is required.

Keep the following minimum installation clearances: 40mm on top, 20mm on the bottom, 5mm left and right side.

Increase the 5mm to 15mm in case the adjacent device is a heat source. When the device is permanently loaded with less than 50%, the 5mm can be reduced to zero.

The device is designed, tested and approved for branch circuits up to 32A (IEC) and 30A (UL) without additional protection device. If an external fuse is utilized, do not use circuit breakers smaller than 6A B- or 3A C-Characteristic to avoid a nuisance tripping of the circuit breaker.

The maximum surrounding air temperature is +70°C. The operational temperature is the same as the ambient or surrounding air temperature and is defined 2cm below the device.

The device is designed to operate in areas between 5% and 95% relative humidity.

### **Installation Instructions for Hazardous Location Areas**

The device is suitable for use in Class I Division 2 Groups A, B, C, D locations.

### **WARNING EXPLOSION HAZARDS!**

Substitution of components may impair suitability for this environment.

Do not disconnect the device or operate the voltage adjustment unless power has been switched off or the area is known to be non-hazardous.

## 3. AC-INPUT

The device is suitable to be supplied from TN-, TT- and IT mains networks with AC voltage. Grounding of one phase is allowed except for UL508 applications.

AC input	Nom.	AC 380-480V	
AC input range		323-576V <sub>a</sub> 576-700V <sub>ac</sub>	For maximal 1s (occasional)
Allowed voltage L or N to earth	Max.	500V <sub>ac</sub>	Continuous operation, according to IEC 62477-1
Input frequency	Nom.	50–60Hz	±6%
Turn-on voltage	Typ.	270V <sub>ac</sub>	Load independent, steady-state value, see Fig. 3-1
Shut-down voltage	Typ.	185V <sub>ac</sub>	At no load
	Typ.	215V <sub>ac</sub>	At 12V, 4A
	Typ.	225V <sub>ac</sub>	At 12V, 8A
External input protection	See recommendations in chapter 2.		

		<b>AC 400V</b>	<b>AC 480V</b>	
Input current	Typ.	0.64A	0.56A	At 12V, 8A, see Fig. 3-3
Power factor	Typ.	0.44	0.42	At 12V, 8A, see Fig. 3-4
Start-up delay	Typ.	75ms	75ms	See Fig. 3-2
Rise time	Typ.	50ms	50ms	At 12V, 8A const. current load, 0mF load capacitance, see Fig. 3-2
	Typ.	85ms	85ms	At 12V, 8A const. current load, 8mF load capacitance, see Fig. 3-2
Turn-on overshoot	Max.	100mV	100mV	See Fig. 3-2

Fig. 3-1 **Input voltage range**

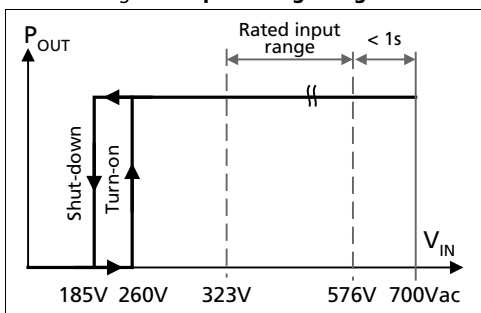

Fig. 3-2 **Turn-on behavior, definitions**

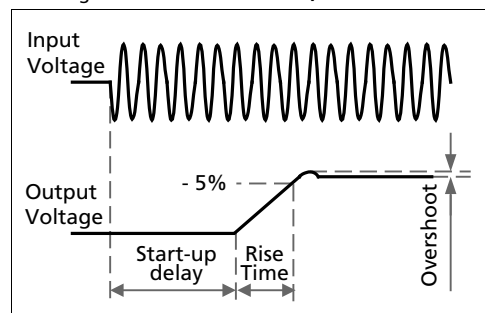

Fig. 3-3 **Input current vs. output load at 12V**

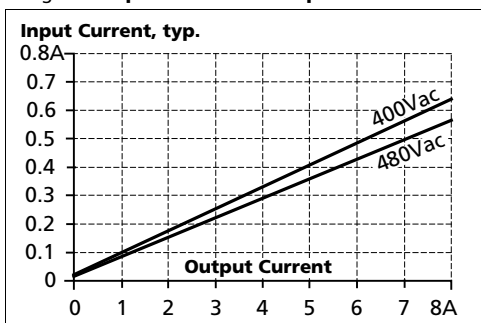
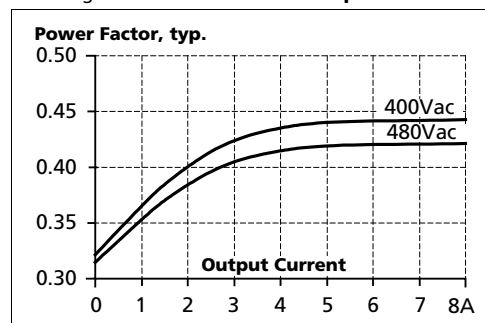

Fig. 3-4 **Power factor vs. output load**



### 4. DC-INPUT

Do not use the power supply with DC-input voltages.

### 5. INPUT INRUSH CURRENT

An active inrush limitation circuit limits the input inrush current after turn-on of the input voltage and after short input voltage interruptions.

The charging current into EMI suppression capacitors is disregarded in the first microseconds after switch-on.

		AC 400V	AC 480V	
Inrush current	Max.	10A <sub>peak</sub>	10A <sub>peak</sub>	Temperature independent
	Typ.	4A <sub>peak</sub>	4A <sub>peak</sub>	Temperature independent
Inrush energy	Max.	0.5A <sup>2</sup> s	0.5A <sup>2</sup> s	Temperature independent

Fig. 5-1 Typical input inrush current behaviour at nominal load and 25°C ambient

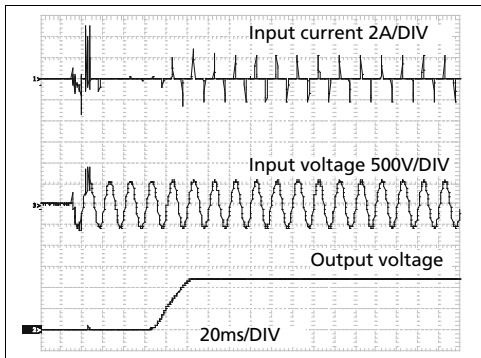

## 6. OUTPUT

The output provides a SELV/PELV rated voltage, which is galvanically isolated from the input voltage. The device is designed to supply any kind of loads, including unlimited capacitive and inductive loads. The output is electronically protected against overload, no-load and short-circuits. In case of a protection event, audible noise may occur.

Output voltage	Nom.	12V	
Adjustment range		12-15V	Guaranteed value
	Max.	16V	This is the maximum output voltage which can occur at the clockwise end position of the potentiometer due to tolerances. It is not a guaranteed value which can be achieved.
Factory setting output voltage	Typ.	12.0V	±0.2% at full load, cold unit
Line regulation	Max.	10mV	Between 323 and 576Vac input voltage change
Load regulation	Max.	100mV	Between 0 and 8A in "single use" mode, static value
Ripple and noise voltage	Max.	100mVpp	Bandwidth 20Hz to 20MHz, 50Ohm
Output current	Nom.	8.0A	At 12V and 60°C ambient temperature
	Nom.	6.0A	At 12V and 70°C ambient temperature
	Nom.	6.4A	At 15V and 60°C ambient temperature
	Nom.	4.8A	At 15V and 70°C ambient temperature
			Reduce output current linearly between +60°C and +70°C
Overload behavior		Continuous current	See Fig. 6-1
Overload/ short-circuit current	Max.	15A	Continuous current, see Fig. 6-1
Output capacitance	Typ.	5 200µF	Included inside the power supply
Back-feeding loads	Max.	25V	The unit is resistant and does not show malfunctioning when a load feeds back voltage to the power supply. It does not matter whether the power supply is on or off. The absorbing energy can be calculated according to the built-in large sized output capacitor.

Fig. 6-1 **Output voltage vs. output current, typ.**

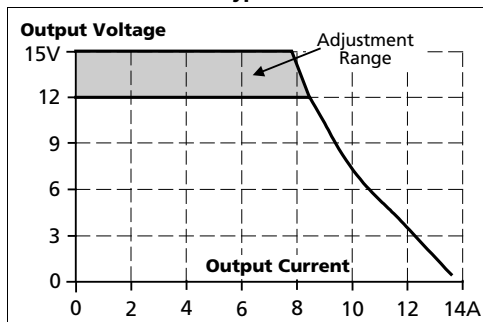

## 7. HOLD-UP TIME

		AC 400V	AC 480V	
Hold-up Time	Typ.	43ms	63ms	At 12V, 8A, see Fig. 7-1
	Typ.	86ms	130ms	At 12V, 4A, see Fig. 7-1
	Min	35ms	53ms	At 12V, 8A, see Fig. 7-1
	Min.	75ms	110ms	At 12V, 4A, see Fig. 7-1

Fig. 7-1 Hold-up time vs. input voltage

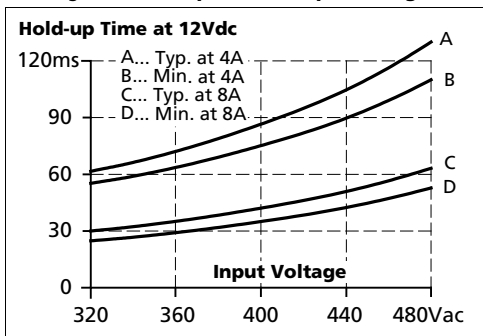
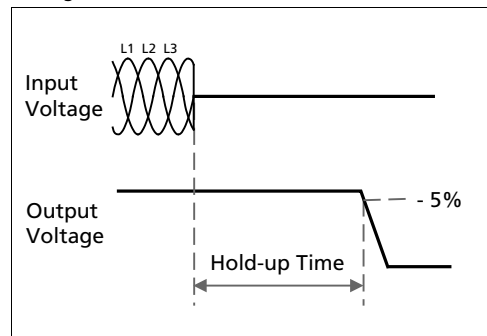

Fig. 7-2 Shut-down behavior, definitions





## 8. EFFICIENCY AND POWER LOSSES

		<b>AC 400V</b>	<b>AC 480V</b>	
Efficiency	Typ.	85.4%	85.8%	At 12V, 8A
Average efficiency *)	Typ.	84.7%	84.1%	25% at 2A, 25% at 4A, 25% at 6A. 25% at 8A
Power losses	Typ.	1.5W	1.6W	At 0A
	Typ.	8.4W	9.1W	At 12V, 4A
	Typ.	16.4W	15.9W	At 12V, 8A

\*) The average efficiency is an assumption for a typical application where the power supply is loaded with 25% of the nominal load for 25% of the time, 50% of the nominal load for another 25% of the time, 75% of the nominal load for another 25% of the time and with 100% of the nominal load for the rest of the time.

Fig. 8-1 **Efficiency vs. output current at 12V, typ.**

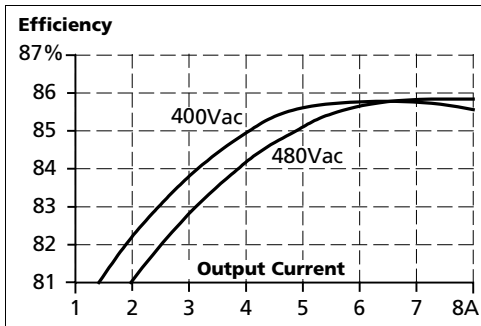

Fig. 8-2 **Losses vs. output current at 12V, typ.**

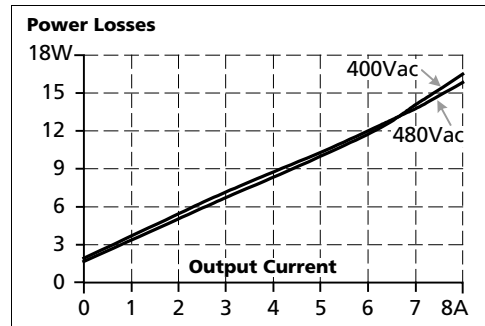

Fig. 8-3 **Efficiency vs. input voltage at 12V, 8A, typ.**

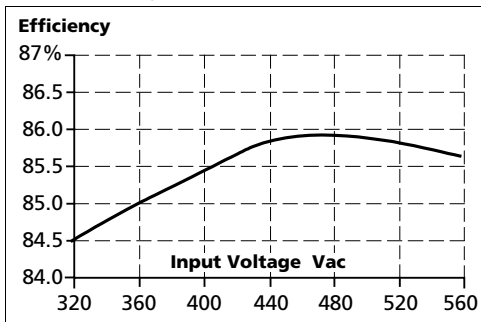
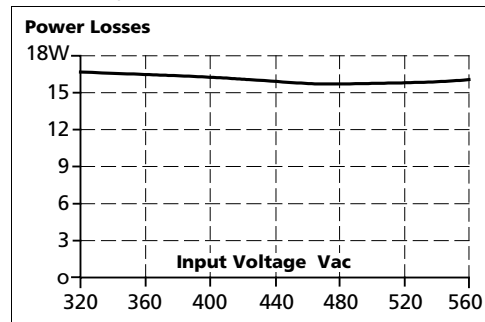
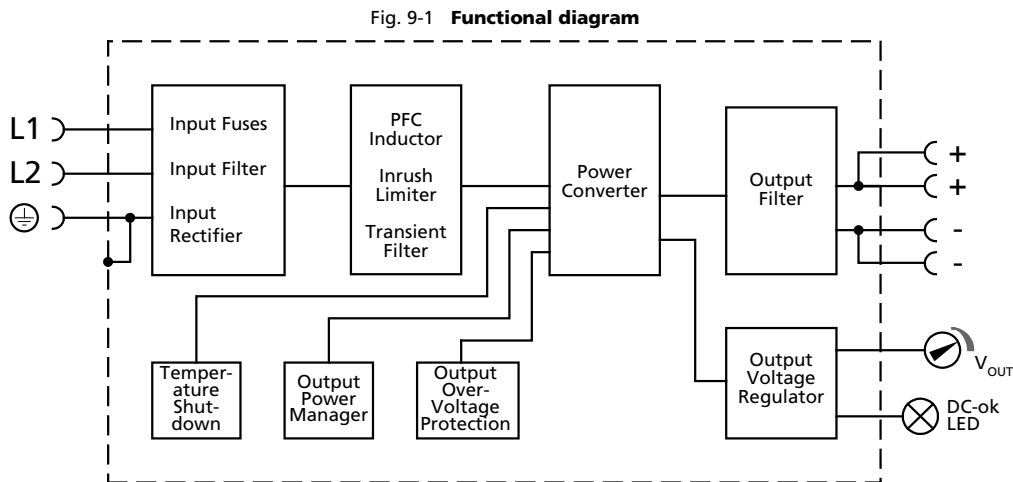

Fig. 8-4 **Losses vs. input voltage at 12V, 8A, typ.**



### 9. FUNCTIONAL DIAGRAM



### 10. FRONT SIDE AND USER ELEMENTS

Fig. 10-1 **Front side**



**A Output Terminals**

- + Positive output (two identical + poles)
- Negative/ return output (two identical - poles)

**B Input Terminals**

- L1, L2 Line input
- ⊕ PE (Protective Earth) input

**C Output voltage potentiometer**

Open the flap to adjust the output voltage. The factory setting is 12.0V

**D DC-OK LED (green)**

On, when the output voltage is above 10.5V.

## 11. CONNECTION TERMINALS

The terminals are IP20 Finger safe constructed and suitable for field- and factory wiring.

	<b>Input</b>	<b>Output</b>
Type	Screw terminal	Screw terminal
Solid wire	Max. 6mm <sup>2</sup>	Max. 6mm <sup>2</sup>
Stranded wire	Max. 4mm <sup>2</sup>	Max. 4mm <sup>2</sup>
American Wire Gauge	AWG 20-10	AWG 20-10
Max. wire diameter (including ferrules)	2.8mm	2.8mm
Recommended tightening torque	1Nm	1Nm
Wire stripping length	7mm	7mm
Screwdriver	3.5mm slotted or Phillips No 1	3.5mm slotted or Phillips No 1

### Daisy chaining:

Daisy chaining (jumping from one power supply output to the next) is allowed as long as the average output current through one terminal pin does not exceed 25A. If the current is higher, use a separate distribution terminal block as shown in Fig. 11-2.

Fig. 11-1 **Daisy chaining of outputs**

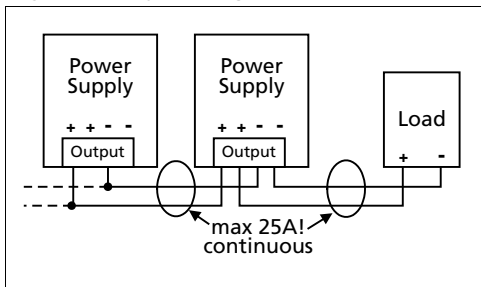
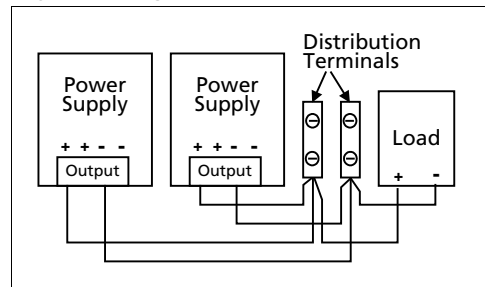

Fig. 11-2 **Using distribution terminals**



## 12. LIFETIME EXPECTANCY

The Lifetime expectancy shown in the table indicates the minimum operating hours (service life) and is determined by the lifetime expectancy of the built-in electrolytic capacitors. Lifetime expectancy is specified in operational hours and is calculated according to the capacitor's manufacturer specification. The manufacturer of the electrolytic capacitors only guarantees a maximum life of up to 15 years (131 400h). Any number exceeding this value is a calculated theoretical lifetime which can be used to compare devices.

	AC 400V	AC 480V	
Lifetime expectancy	51 000h	55 000h	At 12V, 8A and 40°C
	152 000h	147 000h	At 12V, 4A and 40°C
	144 000h	156 000h	At 12V, 8A and 25°C
	430 000h	416 000h	At 12V, 4A and 25°C

## 13. MTBF

MTBF stands for **Mean Time Between Failure**, which is calculated according to statistical device failures, and indicates reliability of a device. It is the statistical representation of the likelihood of a unit to fail and does not necessarily represent the life of a product.

The MTBF figure is a statistical representation of the likelihood of a device to fail. A MTBF figure of e.g. 1 000 000h means that statistically one unit will fail every 100 hours if 10 000 units are installed in the field. However, it can not be determined if the failed unit has been running for 50 000h or only for 100h.

For these types of units the MTTF (**Mean Time To Failure**) value is the same value as the MTBF value.

	AC 400V	AC 480V	
MTBF SN 29500, IEC 61709	982 000h	976 000h	At 12V, 8A and 40°C
	1 799 000h	1 769 000h	At 12V, 8A and 25°C
MTBF MIL HDBK 217F	484 000h	455 000h	At 12V, 8A and 40°C, Ground Benign GB40
	634 000h	599 000h	At 12V, 8A and 25°C, Ground Benign GB25
	105 000h	101 000h	At 12V, 8A and 40°C, Ground Fixed GF40
	137 000h	132 000h	At 12V, 8A and 25°C, Ground Fixed GF25

**14. EMC**

The EMC behavior of the device is designed for applications in industrial environment as well as in residential, commercial and light industry environments. The output is allowed to be grounded or floating.

The device is investigated according to the generic standards EN 61000-6-1, EN 61000-6-2, EN 61000-6-3 and EN 61000-6-4.

**EMC Immunity**

Electrostatic discharge	EN 61000-4-2	Contact discharge Air discharge	8kV 15kV	Criterion A Criterion A
Electromagnetic RF field	EN 61000-4-3	80MHz-2.7GHz	10V/m	Criterion A
Fast transients (Burst)	EN 61000-4-4	Input lines Output lines	4kV 2kV	Criterion A Criterion A
Surge voltage on input	EN 61000-4-5	L1 → L2 L1 → PE, L2 → PE	2kV 4kV	Criterion A Criterion A
Surge voltage on output	EN 61000-4-5	+ → - + / - → PE	500V 1kV	Criterion A Criterion A
Conducted disturbance	EN 61000-4-6	0.15-80MHz	10V	Criterion A
Mains voltage dips	EN 61000-4-11	0% of 380Vac 0% of 480Vac	0Vac, 20ms 0Vac, 20ms	Criterion A Criterion A
Mains voltage dips	EN 61000-4-11	40% of 380Vac 40% of 480Vac 70% of 380Vac 70% of 480Vac	200ms 200ms 500ms 500ms	Criterion C Criterion C Criterion A Criterion A
Voltage interruptions	EN 61000-4-11		5s	Criterion C
Powerful transients	VDE 0160	Over entire load range	1550V, 1.3ms	Criterion A

**Criteria:**

**A:** The device shows normal operation behavior within the defined limits.

**C:** Temporary loss of function is possible. The device may shut down and restarts by itself. No damage or hazards for the device will occur.

**EMC Emission**

Conducted emission input lines	EN 55011, EN 55032, FCC Part 15, CISPR 11, CISPR 32	Class B
Conducted emission output lines	IEC/CISPR 16-1-2, IEC/CISPR 16-2-1	Limits for local DC power networks fulfilled
Radiated emission	EN 55011, EN 55032	Class B
Harmonic input current	EN 61000-3-2	Fulfilled for Class A equipment
Voltage fluctuations, flicker	EN 61000-3-3	Fulfilled, tested with constant current loads, non pulsing

This device complies with FCC Part 15 rules.

Operation is subjected to following two conditions: (1) this device may not cause harmful interference, and (2) this device must accept any interference received, including interference that may cause undesired operation.

**Switching Frequency**

Main converter	45kHz to 170kHz	Output load and input voltage dependent
----------------	-----------------	---

## 15. ENVIRONMENT

Operational temperature	-25°C to +70°C	The operational temperature is the ambient or surrounding temperature and is defined as the air temperature 2cm below the device.
Storage temperature	-40°C to +85°C	For storage and transportation
Output derating	2.5W/K 6W/1000m or 5K/1000m 3.6W/-5kPa or 3K/-5kPa The derating is not hardware controlled. The customer has to take care by himself to stay below the derated current limits in order not to overload the unit.	Between +60°C and +70°C For altitudes >2000m, see Fig. 15-2 For atmospheric pressures <80kPa, see Fig. 15-2
Humidity	5 to 95% r.h.	According to IEC 60068-2-30
Atmospheric pressure	110-47kPa	See Fig. 15-2 for details
Altitude	Up to 6000m	See Fig. 15-2 for details
Over-voltage category	III	According to IEC 60664-1 for altitudes up to 2000m
	II	According to IEC 60664-1 for altitudes from 2000 to 6000m and atmospheric pressures from 80 to 47kPa
Degree of pollution	2	According to IEC 62477-1, not conductive
Vibration sinusoidal	2-17.8Hz: ±1.6mm; 17.8-500Hz: 2g 2 hours / axis	According to IEC 60068-2-6
Shock	30g 6ms, 20g 11ms 3 bumps / direction, 18 bumps in total Shock and vibration is tested in combination with DIN rails according to EN 60715 with a height of 15mm and a thickness of 1.3mm and standard orientation.	According to IEC 60068-2-27
Audible noise	Some audible noise may be emitted from the power supply during no load, overload or short circuit.	

Fig. 15-1 Output current vs. ambient temp.

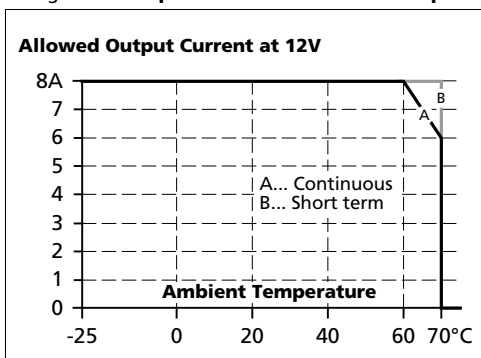
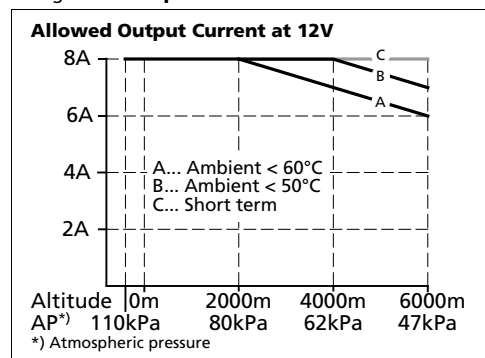

Fig. 15-2 Output current vs. altitude at 12V



## 16. SAFETY AND PROTECTION FEATURES

Isolation resistance	Min.	500MΩ	At delivered condition between input and output, measured with 500Vdc
	Min.	500MΩ	At delivered condition between input and PE, measured with 500Vdc
	Min.	500MΩ	At delivered condition between output and PE, measured with 500Vdc
	Min.	500MΩ	At delivered condition between output and DC-OK contacts, measured with 500Vdc
PE resistance	Max.	0.1Ω	Resistance between PE terminal and the housing in the area of the DIN rail mounting bracket.
Output over-voltage protection	Typ.	18Vdc	In case of an internal defect, a redundant circuit limits the maximum output voltage. The output shuts down and automatically attempts to restart.
	Max.	20Vdc	
Class of protection		I	According to IEC 61140 A PE (Protective Earth) connection is required
Degree of protection		IP 20	According to EN/IEC 60529
Over-temperature protection		Included	Output shuts down with automatic restart. Temperature sensors are installed on critical components inside the unit and turn the unit off in safety critical situations, which can happen e.g. when ambient temperature is too high, ventilation is obstructed or the derating requirements are not followed. There is no correlation between the operating temperature and turn-off temperature since this is dependent on input voltage, load and installation methods.
Input transient protection		MOV (Metal Oxide Varistor)	For protection values see chapter 14(EMC).
Internal input fuse		Included	Not user replaceable slow-blow high-braking capacity fuse
Touch current (leakage current)	Typ.	0.14mA	At 400Vac, 50Hz, TN-,TT-mains
	Typ.	0.19mA	At 480Vac, 60Hz, TN-,TT-mains
	Max.	0.18mA	At 440Vac, 60Hz, TN-,TT-mains
	Max.	0.25mA	At 528Vac, 50Hz, TN-,TT-mains

### 17. DIELECTRIC STRENGTH

The output voltage is floating and has no ohmic connection to the ground.

The output is insulated to the input by a double or reinforced insulation.

Type and routine tests are conducted by the manufacturer. Field tests may be conducted in the field using the appropriate test equipment which applies the voltage with a slow ramp (2s up and 2s down). Connect all input-terminals together as well as all output poles before conducting the test. When testing, set the cut-off current settings to the value in the table below.

Fig. 17-1 Dielectric strength

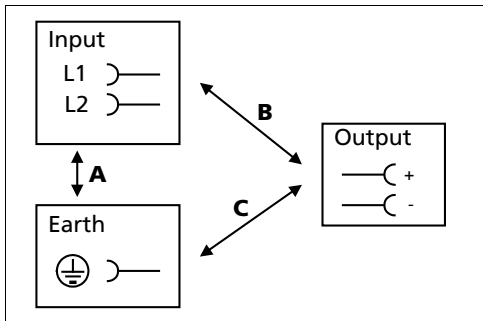

		A	B	C
Type test	60s	2500Vac	3000Vac	500Vac
Routine test	5s	2500Vac	2500Vac	500Vac
Field test	5s	2000Vac	2000Vac	500Vac
Cut-off current setting		> 5mA	> 5mA	> 15mA

It is recommend that either the + pole, the – pole or any other part of the output circuit shall be connected to the earth/ground system. This helps to avoid situations in which a load starts unexpectedly or can not be switched off when unnoticed earth faults occur.



## 18. APPROVED, FULFILLED OR TESTED STANDARDS

UL 508		UL Certificate Listed equipment for category NMTR - Industrial Control Equipment Applicable for US and Canada E-File: E198865
IEC 61010-2-201	<b>Safety</b> ✓	Manufacturer's Declaration Electrical Equipment for Measurement, Control and Laboratory Use - Particular requirements for control equipment
IEC 60950-1	CB Report	CB Scheme Certificate General safety requirements for Information Technology Equipment (ITE)
UL 60950-1		UL Certificate Recognized component for category QQQQ - Information Technology Equipment (ITE) Applicable for US and Canada E-File: E137006
Class I Div 2		CSA Certificate Power Supplies for Hazardous Location Applicable for Canada and US CSA Class: 5318-01 (Canada), 5318-81 (USA) Temperature Code: T3 Groups: A, B, C and D
Marine (DNV)		DNV Certificate DNV Type approved product Certificate: TAA00002YX Temperature: Class D Humidity: Class B Vibration: Class C EMC: Class B Enclosure: Class A
Marine (ABS)	<b>ABS</b>	ABS Design Assessment Certificate ABS (American Bureau of Shipment) assessed product Certificate: 17-HG1599236-PD
VDMA 24364		Paint Wetting Impairment Substances Test (or LABS-Test) Tested for Zone 2 and test class C1 according to VDMA 24364-C1-L/W for solvents and water-based paints

### 19. REGULATORY PRODUCT COMPLIANCE

EU Declaration of  
Conformity



The CE mark indicates conformance with the  
- EMC directive  
- Low-voltage directive  
- RoHS directive

REACH Regulation (EU)



Manufacturer's Declaration  
EU regulation regarding the Registration, Evaluation,  
Authorisation and Restriction of Chemicals (REACH) fulfilled.  
EU Regulation (EC) 1907/2006.

WEEE Regulation



Manufacturer's Declaration  
EU Regulation on Waste Electrical and Electronic Equipment  
Registered as business to business (B2B) products.  
EU Regulation 2012/19/EU

## 20. PHYSICAL DIMENSIONS AND WEIGHT

Width	40mm
Height	124mm
Depth	117mm The DIN rail depth must be added to the unit depth to calculate the total required installation depth.
Weight	500g
DIN rail	Use 35mm DIN rails according to EN 60715 or EN 50022 with a height of 7.5 or 15mm.
Housing material	Body: Aluminium alloy Cover: Zinc-plated steel
Installation clearances	See chapter 2
Penetration protection	Small parts like screws, nuts, etc. with a diameter larger than 3.5mm

Fig. 20-1 **Front view**

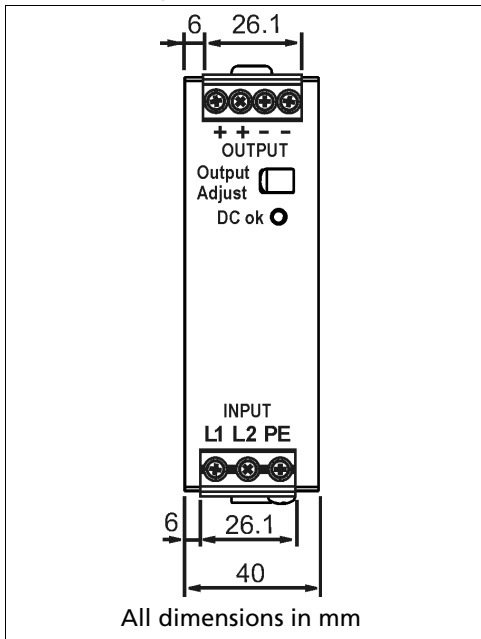
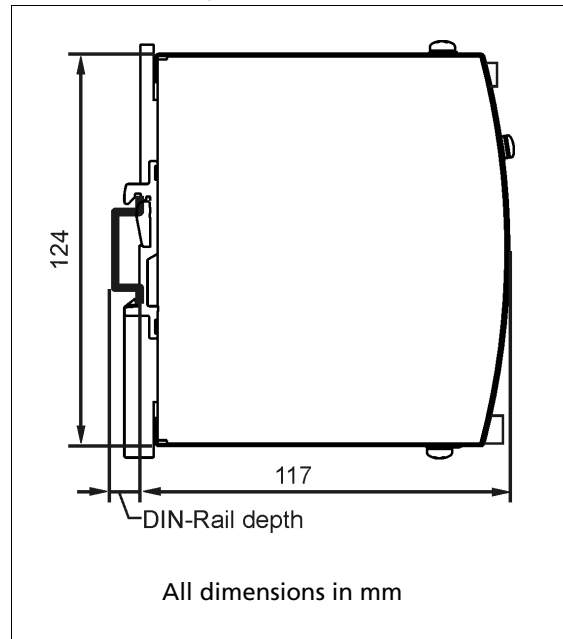

Fig. 20-2 **Side view**



## 21. ACCESSORIES

### 21.1. ZM1.WALL - WALL/PANEL MOUNT BRACKET

These brackets are used to mount the device on a flat surface or panel without utilizing a DIN rail.

The two aluminum brackets and the black plastic slider of the unit have to be detached, so that the steel brackets can be mounted in the holes of the aluminum brackets.

The order number ZM1.WALL contains two brackets needed for one device.

Fig. 21-1 **ZM1.Wall**



Fig. 21-2 **Hole pattern**

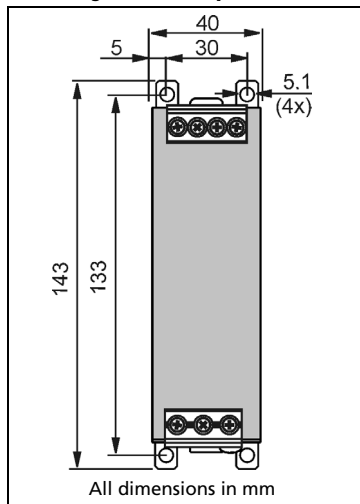

Fig. 21-3 **Side view**

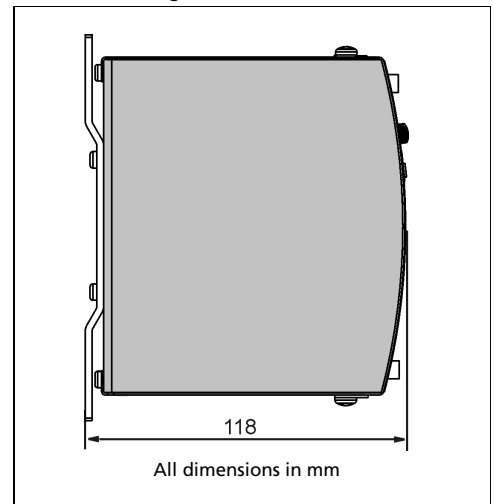

Fig. 21-4 **Isometric view-**

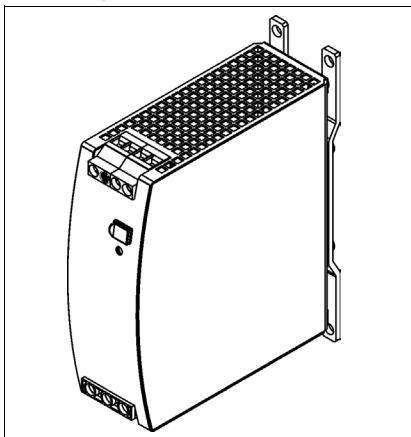

Fig. 21-5 **Isometric view**

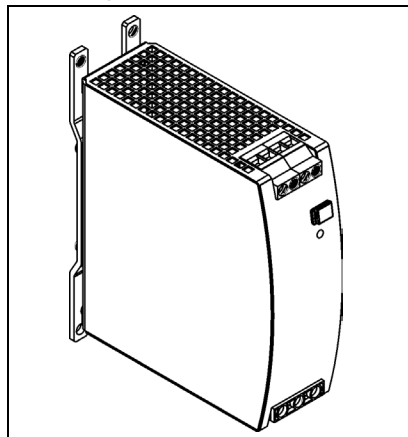
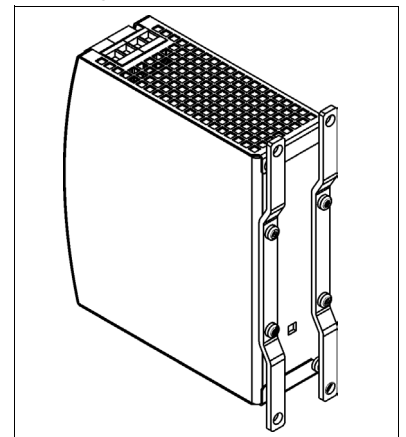

Fig. 21-6 **Isometric view**



### 21.2. ZM12.SIDE - SIDE MOUNT BRACKET

This ZM12.SIDE bracket is used to mount the device sideways with or without utilizing a DIN rail to save installation depth.

The two aluminum brackets and the black plastic slider of the unit have to be detached, so that the ZM12.SIDE steel bracket can be mounted.

For sideways DIN rail mounting, the removed aluminum brackets and the black plastic slider need to be mounted on the ZM12.SIDE steel bracket.



**Fig. 21-7**  
**Side mounting**  
**without DIN rail brackets**

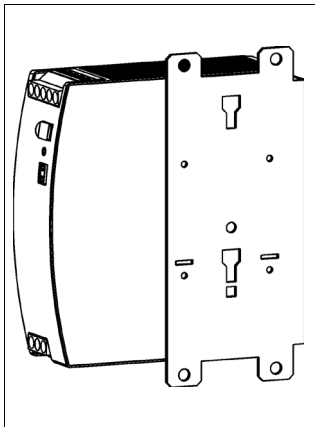

**Fig. 21-8**  
**Side mounting**  
**with DIN rail brackets**

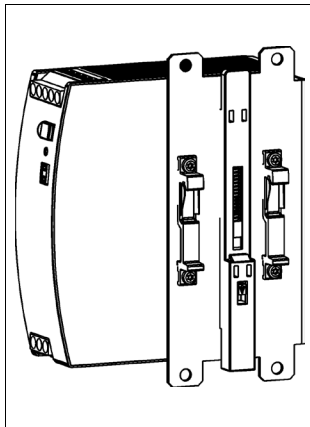

**Fig. 21-9**  
**Hole pattern**

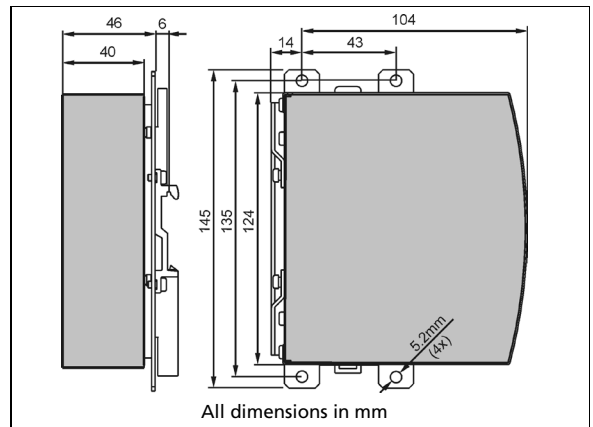

## 22. APPLICATION NOTES

### 22.1. PEAK CURRENT CAPABILITY

The unit can deliver peak currents (up to several milliseconds) which are higher than the specified short term currents. This helps to start current demanding loads. Solenoids, contactors and pneumatic modules often have a steady state coil and a pick-up coil. The inrush current demand of the pick-up coil is several times higher than the steady-state current and usually exceeds the nominal output current (including the PowerBoost). The same situation applies when starting a capacitive load.

The peak current capability also ensures the safe operation of subsequent circuit breakers of load circuits. The load branches are often individually protected with circuit breakers or fuses. In case of a short or an overload in one branch circuit, the fuse or circuit breaker need a certain amount of over-current to open in a timely manner. This avoids voltage loss in adjacent circuits.

The extra current (peak current) is supplied by the power converter and the built-in large sized output capacitors of the power supply. The capacitors get discharged during such an event, which causes a voltage dip on the output. The following examples show typical voltage dips for resistive loads:

Fig. 22-1 **16A peak current for 50ms, typ.**  
(2x the nominal current)

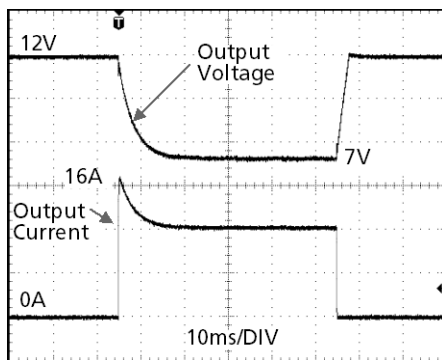
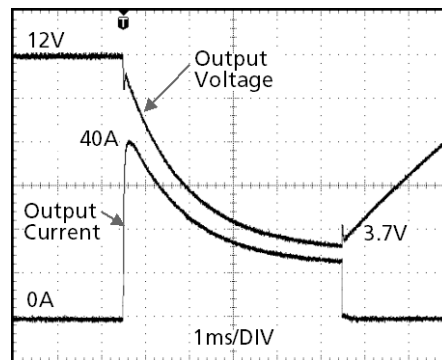

Fig. 22-2 **40A peak current for 5ms, typ.**  
(5x the nominal current)



Peak current voltage dips	Typ.	from 12V to 7V	At 16A for 50ms, resistive load
	Typ.	from 12V to 7V	At 40A for 2ms, resistive load
	Typ.	from 12V to 3.7V	At 40A for 5ms, resistive load

## 22.2. CHARGING OF BATTERIES

The power supply can be used to charge lead-acid or maintenance free batteries.

### Instructions for charging batteries:

- Ensure that the ambient temperature of the power supply stays below 45°C.
- Set the output voltage, measured at no load and at the battery end of the cable, very precisely to the end-of-charge voltage.

End-of-charge voltage	13.9V	13.75V	13.6V	13.4V
Battery temperature	10°C	20°C	30°C	40°C

- Use a 10A circuit breaker or a blocking diode between the power supply and the battery.
- Ensure that the output current of the power supply is below the allowed charging current of the battery.
- The return current to the power supply is typically 5.5mA. This return current can discharge the battery when the power supply is switched off except in case a blocking diode is utilized.

## 22.3. SERIES OPERATION

Devices of the same type can be connected in series for higher output voltages. It is possible to connect as many units in series as needed, providing the sum of the output voltage does not exceed 150Vdc. Voltages with a potential above 60Vdc must be installed with a protection against touching.

Avoid return voltage (e.g. from a decelerating motor or battery) which is applied to the output terminals.

Keep an installation clearance of 15mm (left / right) between two power supplies and avoid installing the power supplies on top of each other. Do not use power supplies in series in mounting orientations other than the standard mounting orientation.

Pay attention that leakage current, EMI, inrush current, harmonics will increase when using multiple devices.

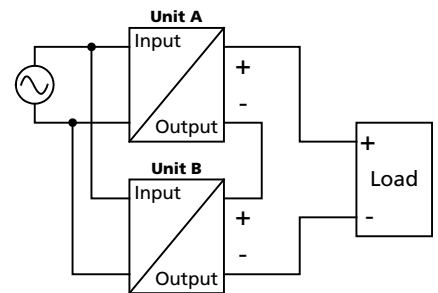

## 22.4. PARALLEL USE TO INCREASE OUTPUT POWER

Devices can be paralleled to increase the output power. The output voltage shall be adjusted to the same value ( $\pm 100\text{mV}$ ) with the same load conditions on all devices, or the devices can be left with the factory settings.

The ambient temperature is not allowed to exceed +45°C.

If more than three devices are connected in parallel, a fuse or circuit breaker with a rating of 10A is required on each output. Alternatively, a diode or redundancy module can also be utilized.

Keep an installation clearance of 15mm (left / right) between two devices and avoid installing the devices on top of each other. Do not use devices in parallel in mounting orientations other than the standard mounting orientation or in any other condition where a reduction of the output current is required (e.g. altitude).

Pay attention that leakage current, EMI, inrush current will increase when using multiple devices.

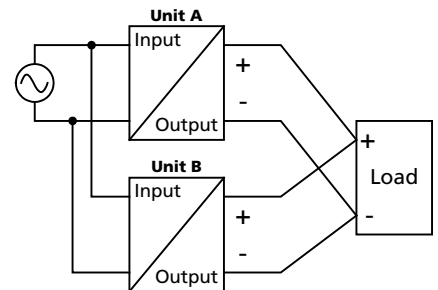

## 22.5. USE IN A TIGHTLY SEALED ENCLOSURE

When the device is installed in a tightly sealed enclosure, the temperature inside the enclosure will be higher than outside. In such situations, the inside temperature defines the ambient temperature for the device.

In the following test setup, the device is placed in the middle of the box, no other heat producing items are inside the box. The load is placed outside the box.

The temperature sensor inside the box is placed in the middle of the right side of the power supply with a distance of 1cm.

The following measurement results can be used as a reference to estimate the temperature rise inside the enclosure.

	<b>Case A</b>	<b>Case B</b>
Enclosure size	110x180x165mm Rittal Typ IP66 Box PK 9516 100, plastic	110x180x165mm Rittal Typ IP66 Box PK 9516 100, plastic
Input voltage	400Vac	400Vac
Load	12V, 6.4A; (=80%)	12V, 8A; (=100%)
Temperature inside the box	51.1°C	56.9°C
Temperature outside the box	25.2°C	25.9°C
Temperature rise	25.9K	31.0K



## 22.6. MOUNTING ORIENTATIONS

Mounting orientations other than input terminals on the bottom and output on the top require a reduction in continuous output power or a limitation in the maximum allowed ambient temperature.

The listed lifetime and MTBF values from this datasheet apply only for the standard mounting orientation.

The following curves give an indication for allowed output currents for altitudes up to 2000m.

Fig. 22-3  
**Mounting Orientation A**  
(Standard orientation)

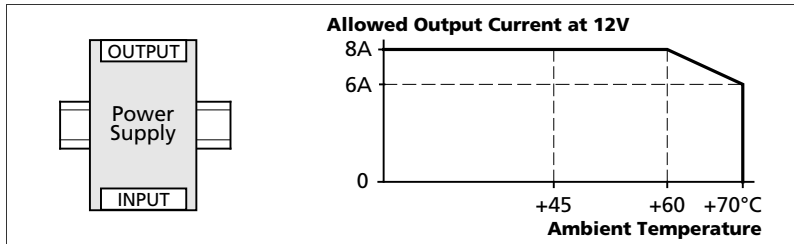

Fig. 22-4  
**Mounting Orientation B**  
(Upside down)

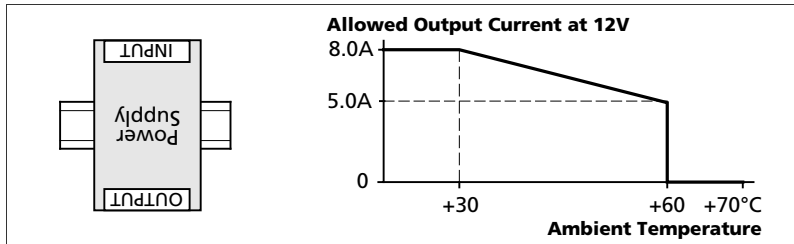

Fig. 22-5  
**Mounting Orientation C**  
(Table-top mounting)

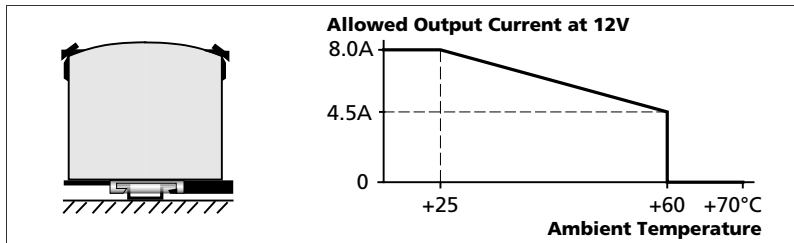

Fig. 22-6  
**Mounting Orientation D**  
(Horizontal cw)

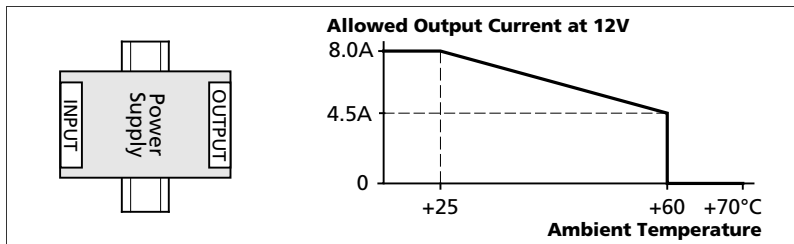
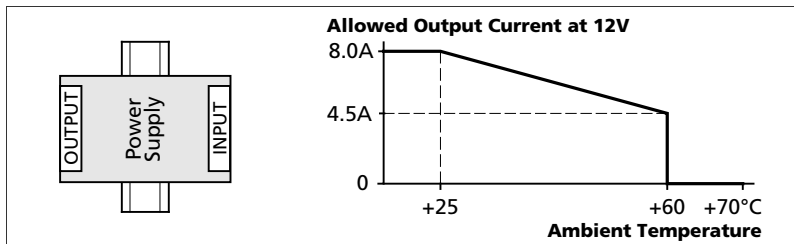

Fig. 22-7  
**Mounting Orientation E**  
(Horizontal ccw)



Aug. 2022 / Rev. 2.2 DS-CT5.121-EN All values are typical figures specified at 400Vac, 50Hz input voltage, 12V, 8A output load, 25°C ambient and after a 5 minutes run-in time unless otherwise noted.